



Project: STOCK UNIT	Consultant:
Location: FLORIDA, United States	Date:

Tag	Model
CHILLER ACDS-VE-1	ACDSV050ARGE

Chiller - ACDSV050ARGE

Description
Tag - CHILLER ACDS-VE-1 <ul style="list-style-type: none"> ▪ Manufacturer DBUSA ▪ Base Price (R-410a Unit, Voltage: 460V/3/60) ▪ MI12:Main incoming isolator ▪ EVH:Evaporator Heater (PHE) ▪ HGBP:Hot gas bypass for low load operation (on circuit 1) ▪ LA3:Low Ambient Version, min. ambient -20F ▪ HGRD:Hail guard (complete unit) ▪ PDT:Pressure Differential Transducer ▪ RFTR:Chilled water reset ▪ BMS:BMS communication-BACnet MSTP ▪ MCHX-E:Microchannel Coil E-Coating ▪ DBD:DB Director ▪ DSIV:Compressor Discharge Isolation Valve ▪ LAL:Low ambient lockout ▪ UVR:Over/under/phase (standard) ▪ Thermal Dispersion Flow Sensor Factory Installed ▪ Capacity (Tons): 56.61, Input power (kW): 68.29, RLA (A): 145, Ampacity: 145, Unit max. fuse/HACR CB size: 175, Refrigerant: R-410a ▪ Fluid flow (USgpm): 135.9, EFT (°F): 54.0, LFT (°F): 44.0, Pressure drop (psi): 7.6, Fouling factor (h-ft²-°F/Btu): 0.00010, Fluid: Water ▪ Design ambient (°F): 96.00, Min. ambient (°F): -20.00, Altitude (ft): 0.00

Shipped loose items

Description
RIS: Rubber isolators



ZEUS

Air Cooled Scroll Chillers
ACDSV(Inverter) 60Hz

ACDSV Cooling Capacity : 10 to 100 TR (35 to 353 kW)



R454B



DUNHAM-BUSH®

Products that perform...By people who care



Project: P-1300	Consultant: Tim Fleshman
Location: NORTH CAROLINA,	Date: 2/5/24 12:03 PM
PERFORMANCE SUMMARY	Tag: CHILLER ACDS-VE-1
	Location:



Scroll Compressor Air Cooled Package Chiller

Model #		ACDSV050ARGE
Quantity	1	Rating version
Manufacturer		ACDG14 DBUSA

Physical Specifications

Compressor Qty	4	Shipping weight	3876
Length	116 in	Operating weight	3911
Width	89 in	Refrigerant	R-410a
Height	88 in	Approx. refrigerant charge	84 lb

Conditions of service

Percent of full load	100%	Compressor power (kW)	59.33
Capacity (Tons)	56.61	Total Fan Power (kW)	8.960
Unit power (kW)	68.29	Cooling Efficiency (EER, Btu /W.hr)	9.947
		NPLV.IP (EER, Btu /W.hr)	17.23

Evaporator

Fluid	Water	Leaving fluid temp. (°F)	44.00
Fluid flow rate (USgpm)	135.9	Fouling factor (h-ft ² -°F/Btu)	0.000100
Entering fluid temp. (°F)	54.00	Pressure drop (psi/ft.H ₂ O)	7.64/17.6
		Fluid freezing point (°F)	32.00

Condenser

Design ambient (°F)	96.0	Altitude (ft)	0.000
Low ambient control to (°F)	-20.0	Fan Motor Power (kW) (Qty)	2.240 (4)

Electrical characteristics

Unit power supply	460V/3ph/60Hz	Unit min. circuit ampacity (A)	145.0
Control power	115V/1ph/60Hz	Unit max inrush	303.0
Unit max. fuse/HACR CB size (A)	175.0	Comp. rated load amps (A)	24.0(1) / 30.0(2) / 36.0(1)
Unit rated load amps	136.0	Comp. locked rotor amps (A)	0.0(1) / 147.0(1) / 197.0(2)

Notes

- Certified in accordance with the AHRI Air Cooled Water-Chilling Packages Using the Vapor Compression Cycle Certification Program, which is based on AHRI Standard-550/590(I-P) and AHRI Standard 551/591(SI). Certified units may be found in the AHRI Directory at www.ahridirectory.org.
- Low ambient control to -20 °F (-28.9 °C) requires 50% minimum load, and a maximum 5 mph wind.
- Meets ASHRAE 90.1-2019 Path B chiller minimum efficiency guidelines
- Refrigerant charge may vary. Unit nameplate will show final factory charge.

NPLV.IP Points

% Full load	Tons	Unit kW	Comp. kW	Fan kW	Evap. EFT	Evap. LFT	EER	Ambient(°F)
100%	56.61	68.29	59.33	8.960	54.00	44.00	9.947	96.0
75%	42.46	38.43	29.47	8.960	51.50	44.00	13.26	80.6
50%	28.31	16.74	15.60	1.139	49.00	44.00	20.29	65.3
25%	14.15	8.376	8.189	0.1870	46.50	44.00	20.28	55.0

Sound Data

Frequency (Hz)	63	125	250	500	1000	2000	4000	8000	Total dB(A)
Sound Pressure Level (free field) at 32.80 ft	15	25	43	52	53	50	48	36	57

*Sound Pressure Level (free field) ± 2 dB(A) Tolerance

Standard Equipment

Unit Construction	Hermetic Tandem Scroll Compressors
--------------------------	---

- Unit shall be constructed of heavy gauge G90 galvanized steel
- All sheet metal parts are painted with oven baked epoxy / polyester powder paint, sustaining 1000 hour salt spray test in accordance with ASTM B-117
- Strap on belt type crankcase heater or sump heater
- Compressor staging on all units
- One (1) year warranty. (Factory provides standard warranty of 12 months from start up or 18 months from shipment date)



Project: P-1300	Consultant: Tim Fleshman
Location: NORTH CAROLINA,	Date: 2/5/24 12:03 PM
PERFORMANCE SUMMARY	Tag: CHILLER ACDS-VE-1
	Location:



- Control panel IP54

whichever occurs first. Limited to parts replacement only and excludes freight, taxes/duties, labours, consumable items, etc. Machine must be well maintained by DB authorized service representative.)

Air Cooled Condenser

- | | |
|--|--|
| <ul style="list-style-type: none"> Microchannel Coil (E-Coating) Subcooling circuit(s) | <ul style="list-style-type: none"> EC fans Standard operation down to 30°F ambient |
|--|--|

Evaporator

- Braze Plate Heat Exchanger(Optional Shell & Tube Heat Exchanger)
- Single and True Dual Evaporator
- Plate material AISI 316
- Fully insulated

Code Compliance

- Units conform to NEC, NEMA, ANSI/ASHRAE 15
- Units conform and certified to ANSI/UL Std. 1995 & CAN/CSA Std. C22.2 No.236 (ETL Listed)

Controls

- | | |
|---|--|
| <ul style="list-style-type: none"> DB Director microcomputer controller on all models Two line 16 character alpha numeric display control functions Compressor loading/staging based on leaving fluid temperature Evaporator fluid freeze protection High and low pressure protection Staggered Staging and modulators of compressors | <ul style="list-style-type: none"> Anti-recycle timing in controller Staging and modularity of condenser fans Accepts remote start & stop signal 0 to 5 VDC chilled water reset signal (standard) Keyboard accessed LCD readouts, continuously updated Discharge and suction pressure for all circuits |
|---|--|

Optional Equipment/Service Included

Factory Mounted Options Included

- Hot Gas By-Pass
- Evaporator Heater (EHTR). Heater provide protection from freezing out to -20°F[-28.9°C] ambient.

Accessories (Shipped Loose)

- Rubber-in-shear isolators (RIS) - designed for ease of installation, these rubber, one piece, molded isolators have skid resistant baseplates. Applicable for most installations.

NOTES:

1. ALL DIMENSIONS ARE IN INCHES [MILLIMETERS].
2. ALLOW 60 [1524] CLEARANCE FOR CONTROL PANEL.
3. EXTERNAL WATER PIPING MUST BE SUPPORTED TO MINIMIZE EXTERNAL WEIGHT ONTO EVAPORATOR OR UNIT.
4. IF VIBRATION ISOLATORS ARE INSTALLED, FLEXIBLE CONNECTIONS SHALL BE INSTALLED AS CLOSE AS POSSIBLE TO THE EVAPORATOR WATER CONNECTIONS TO ISOLATE THE VIBRATION IN THE WATER PIPING.
5. PLEASE CONSULT FACTORY FOR CERTIFIED DRAWING IF OTHER OPTION IS SELECTED.

OPTION ITEMS (TICK WHERE APPLICABLE)

OPTION 1: VIBRATION ISOLATORS

- NIL
- RUBBER ISOLATOR
- SPRING ISOLATOR

OPTION 2: PROTECTIVE PANELS

- NIL
- WIRE MESH (CONDENSER COIL SECTION ONLY)
- HAIL GUARD (COMPLETE UNIT)

OPTION 3: WATER CONNECTOR TYPE

- STANDARD (VICTAULIC)
- FLANGE
- MNPT

DIMENSION CHANGES C/W STANDARD OPTION

- > IF MAIN INCOMING ISOLATOR IS SELECTED, UNIT MAXIMUM LENGTH TO BE INCREASED BY 1" [25.4].
- > IF SOFTSTARTER IS SELECTED, UNIT MAXIMUM LENGTH TO BE INCREASED BY 3 [76.2].
- > IF BOTH MAIN INCOMING ISOLATOR & SOFTSTARTER ARE SELECTED, UNIT MAXIMUM LENGTH TO BE INCREASED BY 4 [101.6].

POINT	P1	P2	P3	P4
POINT LOAD LBS [KG]	924 [419]	858 [389]	865 [392]	874 [396]
SPRING ISOLATOR	DHB-S1-572	DHB-S1-572	DHB-S1-572	DHB-S1-572
RUBBER ISOLATOR	RM-4D-R	RM-4D-R	RM-4D-R	RM-4D-R

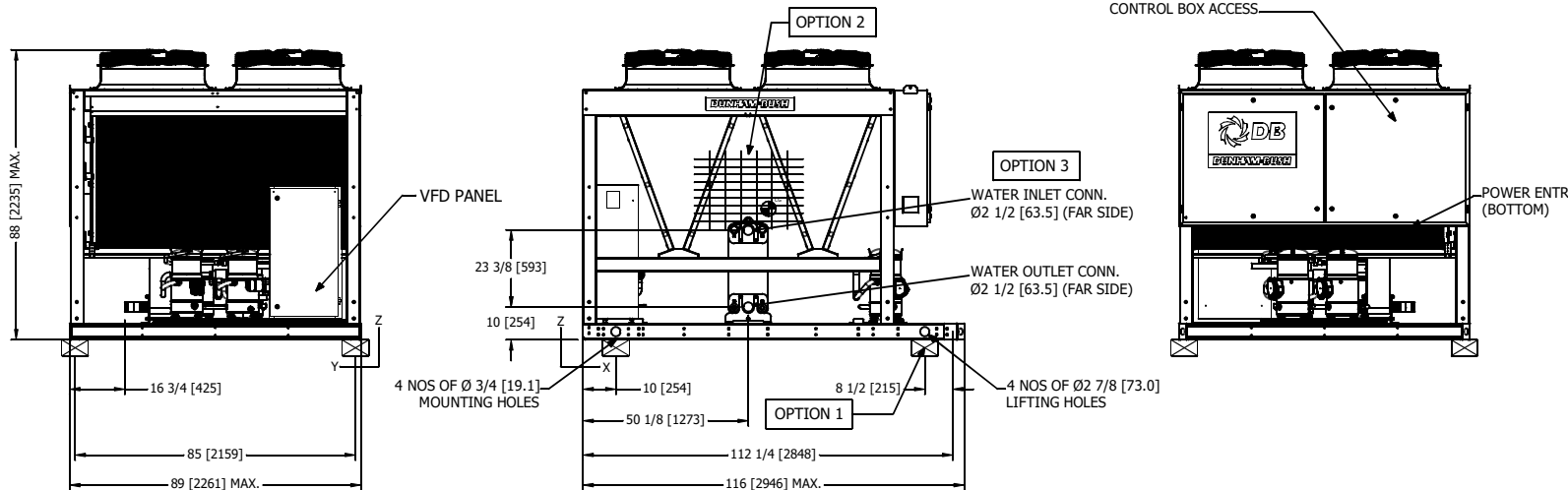
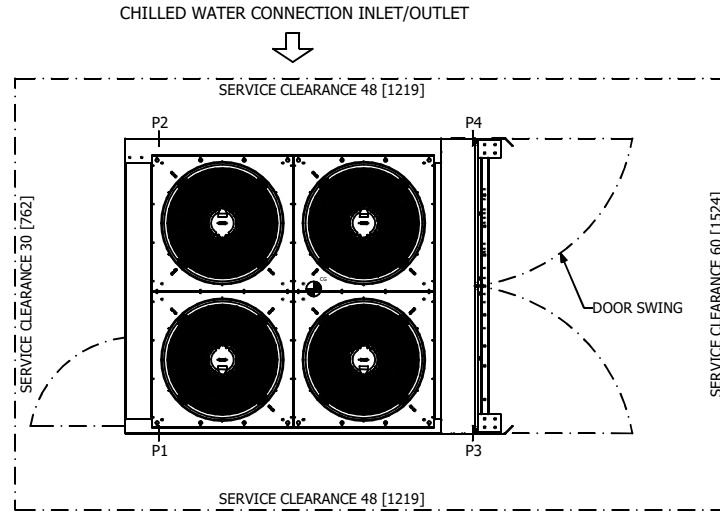

CERTIFIED DRAWING

OPTION 2: PROTECTIVE PANELS

NIL

	SHIPP. WEIGHT LBS [KG]	OPERAT. WEIGHT LBS [KG]	CENTRE OF GRAVITY (X,Y,Z) INCHES
050	3485 [1581]	3520 [1597]	56, 43, 40

CG: CENTRE OF GRAVITY

WIRE MESH (CONDENSER COIL SECTION ONLY)

	SHIPP. WEIGHT LBS [KG]	OPERAT. WEIGHT LBS [KG]	CENTRE OF GRAVITY (X,Y,Z) INCHES
050	3579 [1623]	3614 [1639]	56, 43, 40

CG: CENTRE OF GRAVITY

HAIL GUARD (COMPLETE UNIT)

	SHIPP. WEIGHT LBS [KG]	OPERAT. WEIGHT LBS [KG]	CENTRE OF GRAVITY (X,Y,Z) INCHES
050	3876 [1785]	3911 [1774]	55, 43, 40

CG: CENTRE OF GRAVITY

ALL DIMENSIONS ARE IN INCHES [MM]

DRAWN BY	GANES	DATE	04. 04. 2022
DESIGNED BY	HARIVEEN	DATE	04. 04. 2022
CHECKED BY	CHARLES	DATE	07. 04. 2022
APPROVED BY	KS LAU	DATE	07. 04. 2022

REV	DESCRIPTION	DATE	DRN BY



DUNHAM-BUSH
USA LLC

THIS DOCUMENT IS THE PROPERTY OF DUNHAM-BUSH, USA LLC AND SHOULD NOT BE DISCLOSED OR USED WITHOUT THE EXPRESSED CONSENT OF THE COMPANY. DUNHAM-BUSH RESERVES THE RIGHT TO MAKE CHANGES WITHOUT PRIOR NOTICE

LOCATION.

QTY.

MODEL ACDSV050-E 60Hz

PROJECT STANDARD

TITLE

AIR COOLED CHILLER

DRAWING NO 93299G-118 **REV:** 1.0

SCALE : N. T. S. SHEET 1 OF 1



Magnum HVAC Version 17

Rev. 2.3.7 - REV-2022-10-24

*View Changes made since
last Version Release,
see page 2*

5580 Enterprise Pkwy.
Fort Myers, FL 33905

Office: 239-694-0089
Fax: 239-694-0031

www.mcscontrols.com

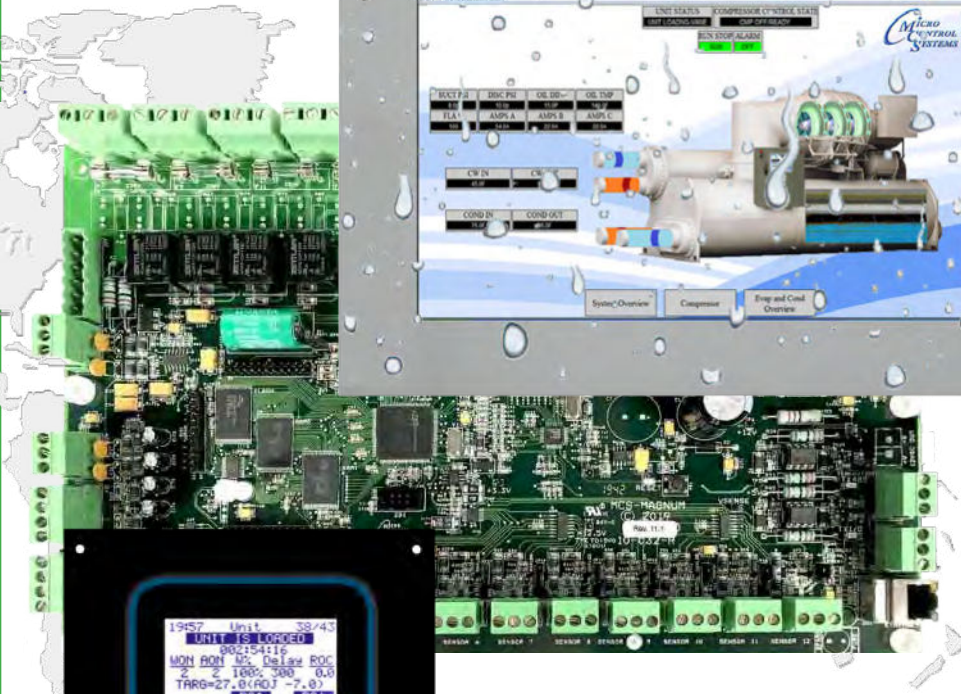

**Magnum / Compressor
Control States
BMS Protocols, Set Points,
Alarms & Safeties**

**MCS Total
Solution
for all your
Control
Needs**



**Energy Efficient and
RoHS Compliant**

Chapter - 28. BMS Communication Protocols

The MCS-Magnum supports as standard: BACnet IP, Modbus RTU, and Modbus TCP/IP protocols.

Using the MCS-BMS-GATEWAY, the MCS-Magnum can also support Johnson N2, LonTalk and Bacnet MSTP.

Supported baud rates for Modbus RTU and Johnson N2 are 4800bps, 9600bps, 19200bps, 38400bps, and 57600bps.

28.1. MCS-Magnum to BMS Connections

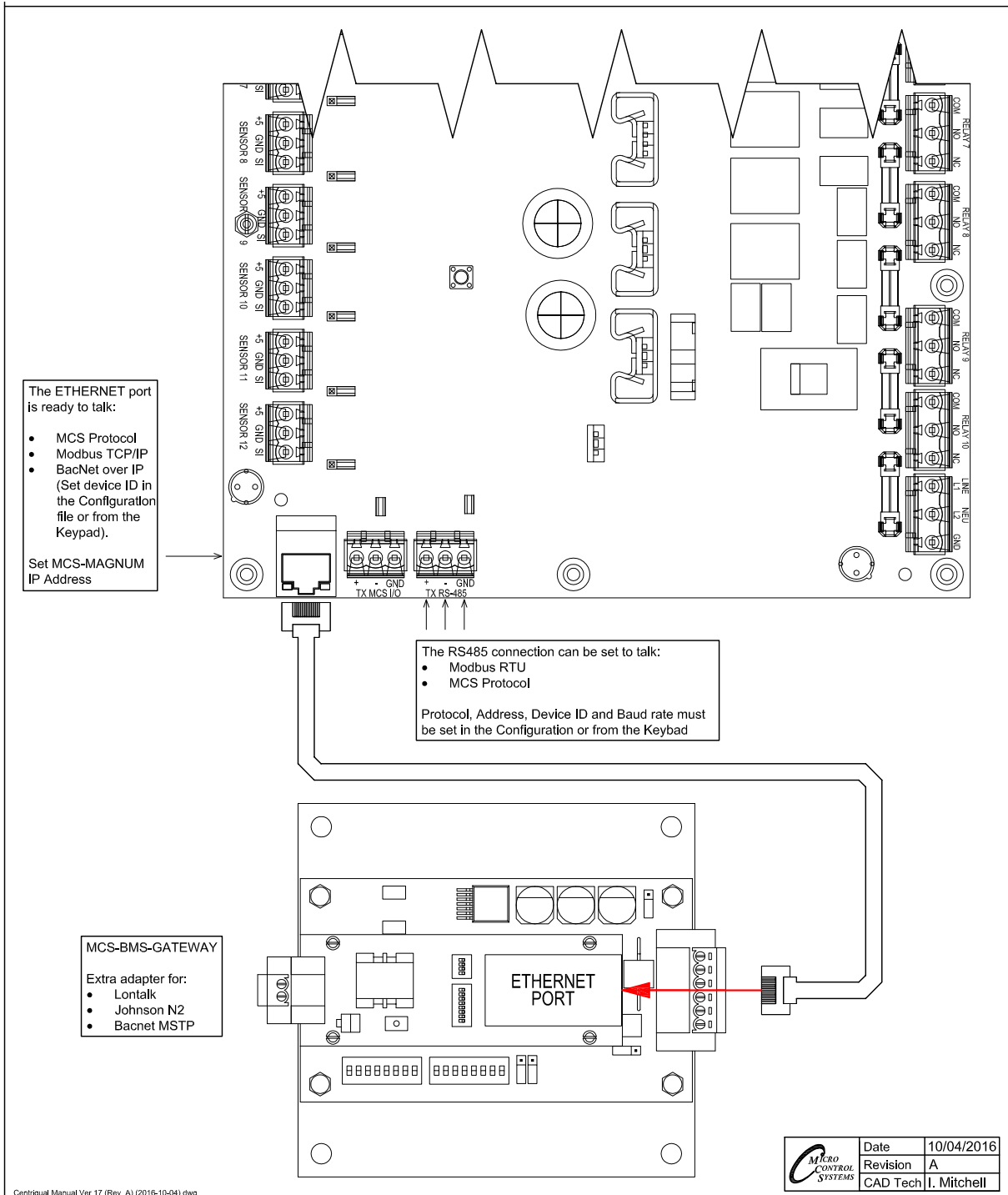

Centrigual Manual Ver 17 (Rev. A) (2016-10-04).dwg



RUBBER IN SHEAR MOUNT (RMD Series Double Deflection)

RMD Series are elastomeric mounts which provide effective vibration control for all types of rotating machines. The RMD Series double deflection rubber in shear mounts are color coded for identification of loading capacity and prevents installation errors. The RMD Series have ribbed and non-skid bases. No bolting of anchor bolts is required for machines that have no lateral motion.

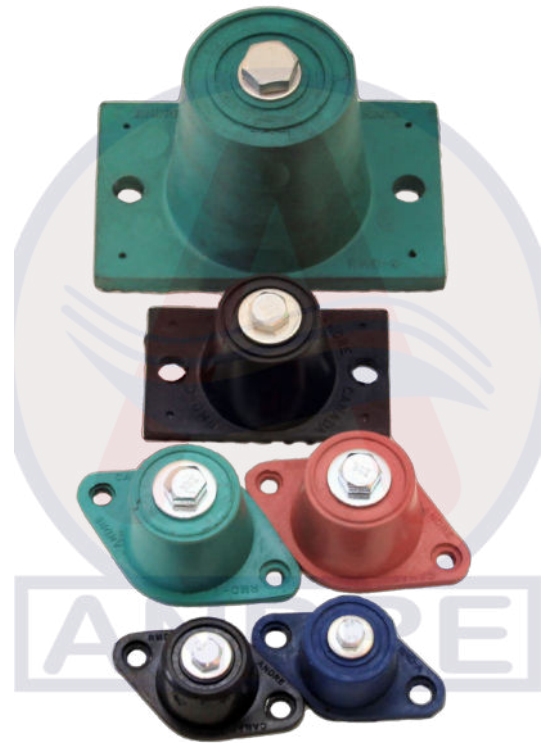
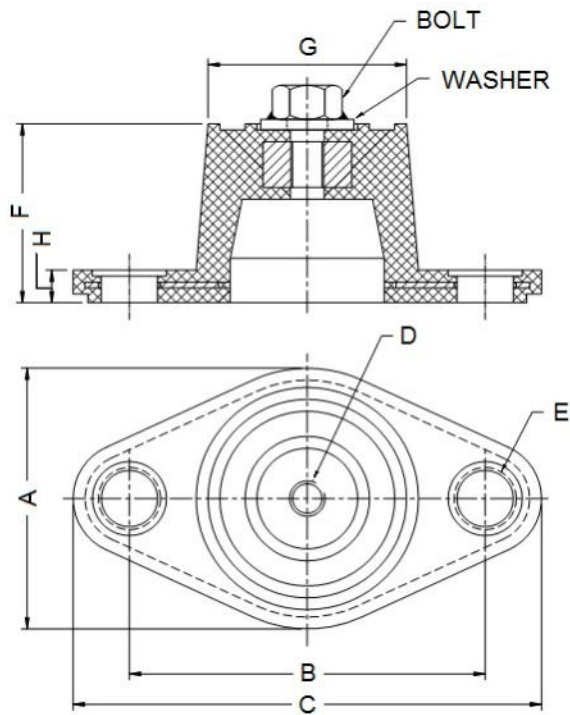

FEATURES:

- Anti-skid top and bottom surfaces
- Mounting holes provided as standard.
- Embedded steel plates for uniform loading.
- Oil and water resistant
- High deflection
- Color coded for easy identification
- Material: Polymer compound

NOTES:

- Models RMD-C and RMD-D have rectangular bases
- Drawing: Not to Scale

APPLICATIONS:

- Air handling units
- Compressors
- Fans
- Pumps
- HVAC Equipments
- Generators
- Transformers

RMD Isolator Information is listed on the following page



ANDRE HVAC International Inc

Isolator Model	Max Load (lbs)	Deflection (inches)	Isolator Dimensions (inches)								Color
			A	B	C	D	E	F	G	H	
RMD-A-1	30	0.35	1-3/4	2-3/8	3-1/8	1/4	11/32	1-1/4	1-3/8	3/16	Blue
RMD-A-2	40	0.35	1-3/4	2-3/8	3-1/8	1/4	11/32	1-1/4	1-3/8	3/16	Red
RMD-A-3	70	0.35	1-3/4	2-3/8	3-1/8	1/4	11/32	1-1/4	1-3/8	3/16	Green
RMD-A-4	115	0.35	1-3/4	2-3/8	3-1/8	1/4	11/32	1-1/4	1-3/8	3/16	Black
RMD-B-1	130	0.40	2-3/8	3	3-7/8	3/8	11/32	1-3/4	1-3/4	7/32	Blue
RMD-B-2	165	0.40	2-3/8	3	3-7/8	3/8	11/32	1-3/4	1-3/4	7/32	Red
RMD-B-3	235	0.40	2-3/8	3	3-7/8	3/8	11/32	1-3/4	1-3/4	7/32	Green
RMD-B-4	375	0.40	2-3/8	3	3-7/8	3/8	11/32	1-3/4	1-3/4	7/32	Black
RMD-C-1	200	0.50	2-3/8	3-1/8	4	3/8	1/2	2	1-3/4	1/4	Blue
RMD-C-2	300	0.50	2-3/8	3-1/8	4	3/8	1/2	2	1-3/4	1/4	Red
RMD-C-3	400	0.50	2-3/8	3-1/8	4	3/8	1/2	2	1-3/4	1/4	Green
RMD-C-4	500	0.50	2-3/8	3-1/8	4	3/8	1/2	2	1-3/4	1/4	Black
RMD-D-1	750	0.50	3-5/8	4-3/4	5-7/8	1/2	9/16	3-1/2	2-3/4	3/8	Blue
RMD-D-2	1000	0.50	3-5/8	4-3/4	5-7/8	1/2	9/16	3-1/2	2-3/4	3/8	Red
RMD-D-3	1500	0.50	3-5/8	4-3/4	5-7/8	1/2	9/16	3-1/2	2-3/4	3/8	Green
RMD-D-4	2200	0.50	3-5/8	4-3/4	5-7/8	1/2	9/16	3-1/2	2-3/4	3/8	Black
RMD-D-5	3300	0.50	3-5/8	4-3/4	5-7/8	1/2	9/16	3-1/2	2-3/4	3/8	Black (White Dot)

prosense® FTS Series Liquid / Air Thermal Flow Sensors

Dimensions

mm [inches]

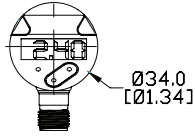

Dimensions mm [inches]	
Part No.	A
FTS100-100x	100mm [3.94 in]
FTS200-100x	200mm [7.87 in]

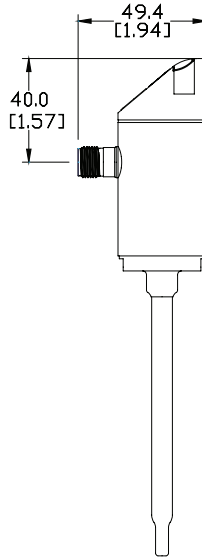
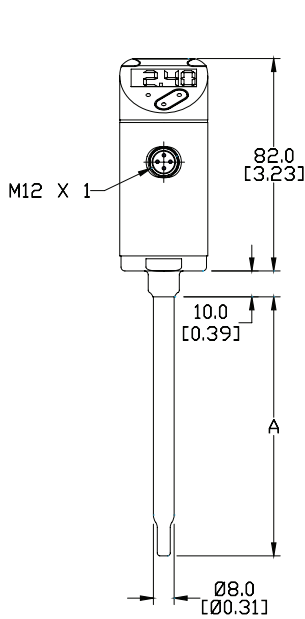

See our website www.AutomationDirect.com for complete Engineering drawings.

proSense® FTS Series (-1001) Liquid / Air Thermal Flow Sensors

ProSense FTS Series (-1001) Thermal Flow Sensors Specifications Continued		
Model	<u>FTS100-1001</u>	<u>FTS200-1001</u>
	Outputs Continued	
Analog Output	4 to 20 mA (scalable) Max. load: 350Ω	
Short-Circuit Protection	Yes	
Overload Protection	Yes	
	Measuring Range	
Probe Length (mm)	100mm	200mm
	Liquids (Water & Glycol Solutions)	
Measuring Range	0.15 to 9.85 ft/s	
Setting Range	0 to 9.85 ft/s	
Glycol Reference Medium*	35% Ethylene glycol solution	
	Gases (Air)	
Measuring Range	6 to 328 ft/s	
Setting Range	0 to 328 ft/s	
	Temperature Monitoring	
Measuring Range	-4 to 212°F (-20 to 100°C)	
Resolution	0.5°F	
	Accuracy / Deviations	
	Flow Monitoring	
Temperature Drift [fps x 1/K]	0.01 fps x 1/K (< 68°F; > 158°F)	
Max. Temperature Gradient of Medium [K/min]	100	
Accuracy (In the Measuring Range)	7% measured value (MW) + 2% measured end value (MEW); water: 68 to 158 °F; inlet length: 5 ft; DN25 (DIN 2448); mounting position according to instructions; Accuracy can differ for other media and mounting positions.	
Repeatability	0.05 m/s; (water; Flow velocity: 0.05 to 3 m/s)	
	Temperature Monitoring	
Temperature Drift	± 0.003 K/°F	
Accuracy [K]	± 0.3 / ± 1; (water; Flow velocity: 1 to 9.85 fps / air; Flow velocity: > 32.8 fps)	
	Reaction Times (per DIN EN 60751)	
Flow Response Time	Water; glycol: 0.8 s; air: 7 s (each T09)	
Temperature Response Time	1.5 s (T09); (water; Flow velocity: 1 to 9.85 fps)	

*The glycol medium setting on the sensor is designed for a 35% glycol/water solution. Increasing the glycol concentration decreases the measured value. Likewise, decreasing the concentration increases the measuring value. For a concentration of 50% glycol, there is an estimated decrease in measured value of about -25%. For a concentration of 15% glycol, there is an estimated increase in the measured value of about +25%.

ProSense® FTS Series (-1001) Liquid / Air Thermal Flow Sensors

ProSense FTS Series (-1001) Thermal Flow Sensors Specifications Continued		
Model	<u>FTS100-1001</u>	<u>FTS200-1001</u>
Operating Conditions		
Ambient temperature	-40 to 176°F (-40 to 80°C)	
Storage temperature	-40 to 212°F (-40 to 100°C)	
Protection	IP 65; IP 67	
Tests / Approvals		
EMC	DIN EN 60947-5-9	
Shock resistance	DIN EN 60068-2-27 @ 50 g (11 ms)	
Vibration resistance	DIN EN 60068-2-6 @ 5 g (10 to 2000 Hz)	
UL approval	E320431	
CE	EMC; RoHS II	
Mechanical Data		
Weight	0.65 lb (296.5 g)	
Material	Stainless steel (1.4404 / 316L); PBT-GF20; PBT-GF30	
Materials (wetted parts)	Stainless steel (1.4404 / 316L)	
Process Connection	Diameter 8mm	
Displays / Operating Elements		
Display	Display Unit: 5 x LED, green (fps, gpm, cfm, °F, 10 ³)	
	Switching status: 2 x LED, yellow	
	Measured values: alphanumeric display, red/green 4-digit, 9mm character height	
Electrical Connection		
Connector	1 x M12	
Contacts	Gold plated	



NOTE: CHECK THE CHEMICAL COMPATIBILITY OF THE SENSOR'S WETTED PARTS WITH THE MEDIUM TO BE MEASURED.

Wiring Diagram

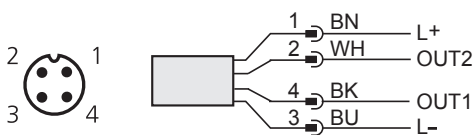

Cable Assembly Wiring Colors:

- Pin 1 - Brown
- Pin 2 - White
- Pin 3 - Blue
- Pin 4 - Black

Colors to DIN EN 60947-5-2

For additional wiring details see individual product manuals.

Note: Wiring colors are based on AutomationDirect CD12L and CD12M 4-pole cable assemblies.

Output Function Selections

Models:
FTS100-1001. FTS200-1001

Output 1:
Switching output Volumetric flow rate monitoring
Frequency output Volumetric flow rate monitoring

Output 2:
Switching output Volumetric flow rate monitoring
Switching output Temperature monitoring
Analog output Volumetric flow rate monitoring
Analog output Temperature monitoring
Frequency output Volumetric flow rate monitoring
Frequency output Temperature monitoring



Click or scan the above QR code to be taken to the installation insert for the FTSx00-1001 Liquid / Air Thermal Flow Switches

pro^{sense}® FTS Series Liquid / Air Thermal Flow Sensors

Liquid Flow Conversions

To convert from flow velocity to flow rate, use the following formula:

$$V = v \times A$$

Where V = volumetric flow rate

v = flow velocity

A = cross sectional area of the pipe

Take care to ensure all the units of measure are consistent. The following charts can be used in lieu of the calculation for round pipes. Find the volumetric flow rate on the y-axis. (Example: 10 GPM) Follow the line horizontally until it intersects the line for pipe diameter. (Example: 3/4" pipe diameter). From the intersection point, drop straight down to read the x-axis to find the given flow velocity. (Example: 6 ft/sec)

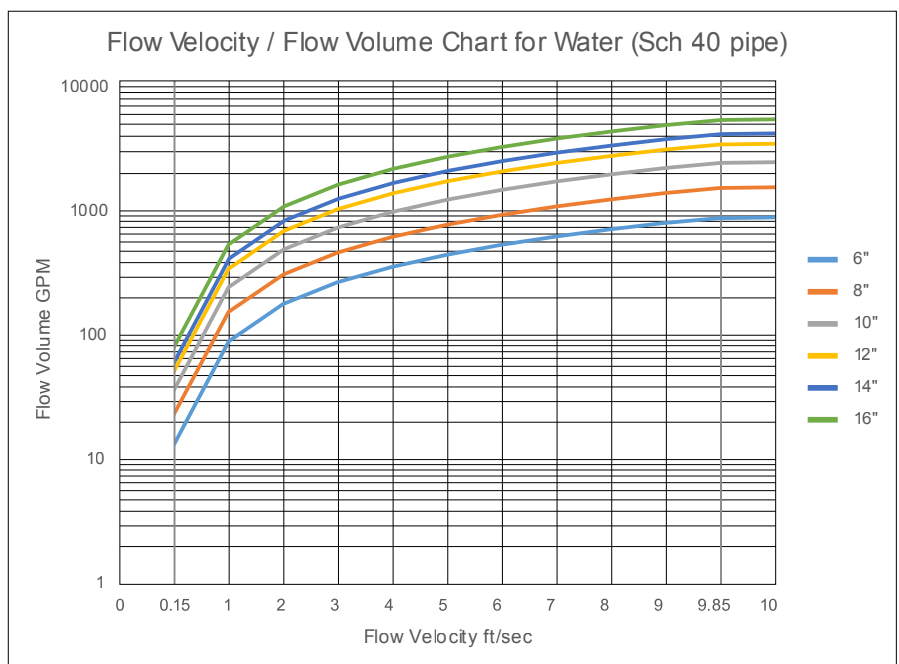
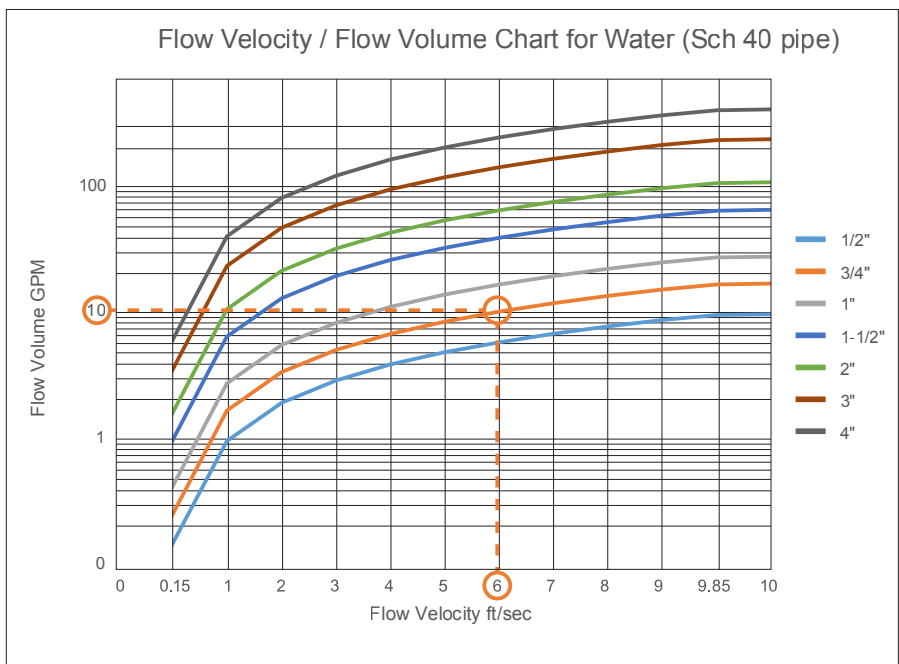

GENERAL CHARACTERISTICS

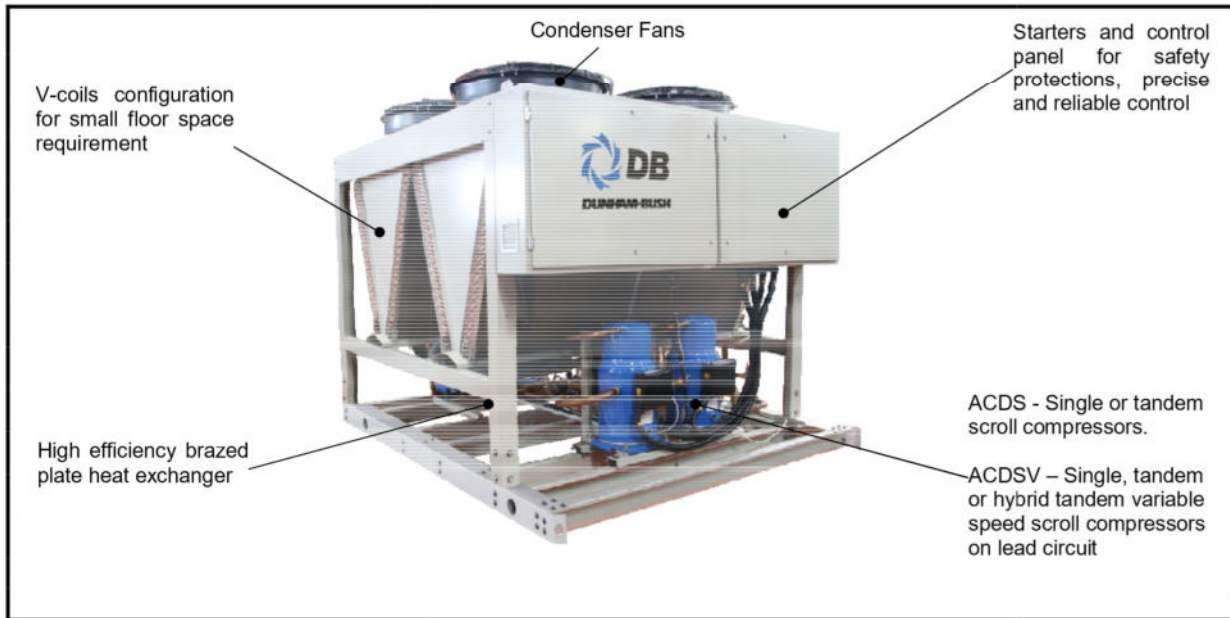

UNIT FEATURES

GENERAL

- ✦ ACDS- 15 models from 10 to 180TR [35 to 632kW]
- ✦ ACDSV- 10 models from 10 to 100TR [35 to 353kW]

- ✦ Units are rated and certified with AHRI standard 550/590
- ✦ ETL listed units
- ✦ Unit operating ambient temperature:
ACDS - 45 ~ 115°F [7 ~ 46°C]
ACDSV - 0~105°F [-18°C ~41°C]

COMPRESSORS

- ✦ ACDS- Single or tandem fixed speed scroll configuration.
- ✦ ACDSV- Single inverter or hybrid inverter tandem scroll compressors on lead circuit. Fix speed tandem compressors on second circuit (if applicable)
- ✦ Oil level sensor on inverter compressor to provide feedback to unit controller to activate the oil recovery logic when required.
- ✦ Suction gas cooled motor
- ✦ High EER
- ✦ Inverter compressor motor protection by drive
- ✦ Crankcase heaters or sump heaters are provided to minimized oil dilution and liquid refrigerant migration

UNIT CASING

- ✦ Casing is constructed from heavy gauge galvanized steel

- ✦ Powder coated baked finishing, offers excellent corrosion resistance for outdoor applications, which withstand up to 1000 hours salt spray test in accordance to ASTM B-117



EVAPORATOR

- ✦ Compact and high efficiency brazed plate heat exchanger
- ✦ Constructed with stainless steel plates
- ✦ Design pressure of 450 psig [31 bar] on refrigerant circuit
- ✦ Design pressure of 400 psig [28 bar] on fluid circuit
- ✦ Environment friendly with reduced refrigerant charged by its compact design

UNIT FEATURES



- ✦ Lower pressure drop on water side
- ✦ Victaulic groove fluid connection
- ✦ 1" [25mm] thick closed cell insulation
- ✦ For ACDS165 & 180, standard units are with shell & tube condenser.

CONDENSER AND FANS

- ✦ ACDS – Constructed with seamless inner-grooved copper tubes expanded into die-formed aluminum fins in staggered configuration.
- ✦ ACDSV - Condenser is light-weight aluminum alloy microchannel coil with flat tubes containing multiple, parallel flow microchannels layered between the refrigerant manifold piping (except for ACDSV010 is using finned tube Cu-Al coil). Standard coating on microchannel coil is TCP coating (i.e., anti-corrosion protective coating)
- ✦ Leak and pressure test at 650psig [45bar]
- ✦ Coil design with sub-cooling enhancement to improve unit efficiency
- ✦ ACDS – Low noise direct driven propeller fans.
- ✦ ACDSV - Low noise direct driven propeller fans with EC fan motor
- ✦ IP 54 motor construction for outdoor applications

FACTORY TESTING

- ✦ Each chiller undergoes the factory testing prior to unit shipment. This assures consistencies of workmanship at highest quality
- ✦ Thus, all units shipped are completely factory tested; charged and adjusted according to the design parameters, for ease of installation and minimal field start-up adjustments

ELECTRICAL AND CONTROL

- ✦ Weather tight electrical enclosure fabricated by heavy gauge sheet steel with powder coated baked finishing.
- ✦ Single point power connection for all models
- ✦ Circuit breaker for compressors and condenser fan motors.
- ✦ Unit mounted VFD or Direct On-Line (DOL) starter for compressors and condenser motors. For EC condenser fan motors do not require a starter.

- ✦ Overload protection for non-inverter compressor motors
- ✦ Step down transformer for control circuit
- ✦ Main power supply monitoring module (OUVR) giving protection on under or over voltage, phase reversal, phase losses and imbalance
- ✦ Built-in anti-recycle timer for compressors to avoid excessive motor winding temperature rise due to frequent motor startup
- ✦ DB Director is used as the unit controller

DB DIRECTOR

DB-Director is a rugged microprocessor-based controller designed for the HVAC/R applications. DB-Director provides flexibility with setpoints and control options that can be selected prior to commissioning a system or when the unit is live and functioning. Displays, alarms and other interfaces are accomplished in a clear and simple language that informs the user as to the status of the controller.

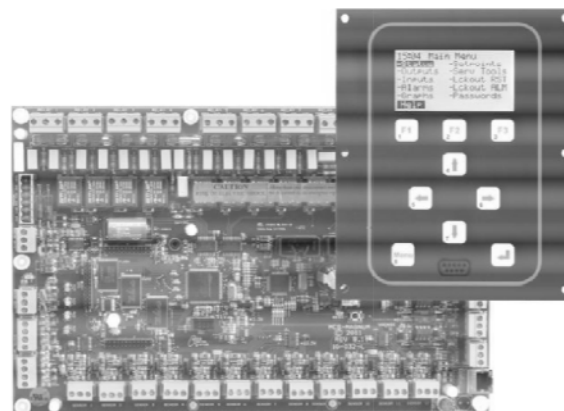

DB-Director is equipped with 128 x 64 pixels monochrome graphics LCD display with 2.8" diagonal viewing area, and 9 dedicated keys that enable user to access information, based on security level of the password. The user terminal allows displaying and easy access to the unit working conditions, compressor run times, alarm histories and modify the parameters. Multiple messages will be displayed by automatically scrolling from each message to the next. All of these messages are spelled out in English language on the display terminal.

The display also has an automatically self-test of the controller on system start-up. For more detail operation of the DB-Director keypad, please refer to the Unit operation Manual.

Remote Monitoring

DB-Director is equipped with RS485 and Ethernet communication ports as standard. This user-friendly design allows Building Management System (BMS) to interface directly with the chiller via either of Modbus RTU, Modbus IP, or BACnet IP communication protocol. LONworks or BACnet MSTP communication protocol can be established with installation of external adapter.



PHYSICAL SPECIFICATIONS (ACDSV)

Model ACDSV	010	020	030	040	050
Unit Nominal Capacity TR[kW]	10.3 [36.1]	19.6 [68.9]	29.6 [104.0]	41.7 [146.5]	54.3 [190.8]
Unit Nominal Power Input kW	12.3	23.4	35.2	46.2	63.1
EER	10.1	10.1	10.1	10.4	10.3
COMPRESSOR					
Min. % Unit Capacity	20%	25%	25%	25%	25%
No. Of Refrigerant Circuit	1	1	1	2	2
EVAPORATOR					
Water Connector Inches[mm]	2.0 [50.8]	2.0 [50.8]	2.0 [50.8]	2.5[63.5]	2.5[63.5]
Nominal Water Flow USgpm[m ³ /hr]	24.7 [5.7]	47.1 [10.7]	71.1 [16.2]	100.1 [22.8]	130.4 [29.7]
Nominal Pressure Drop ft.wg[kPa]	12.2 [36.3]	10.7 [31.9]	15.6 [46.6]	15.3 [45.8]	16.4 [48.9]
Min/Max. Water Flow USgpm[m ³ /hr]	12.4 / 41.1 [2.9 / 9.4]	23.6 / 78.4 [5.4 / 17.9]	35.6 / 118.4 [8.1 / 26.9]	50.1 / 166.8 [11.4 / 37.9]	65.2 / 217.2 [14.9 / 49.4]
Min/Max. Water Pressure Drop ft.wg[kPa]	3.5 / 30.7 [10.3 / 91.8]	3 / 27.3 [8.9 / 81.4]	4.3 / 40.4 [12.9 / 120.7]	4.4 / 38.6 [13.2 / 115.2]	4.7 / 41.1 [14 / 122.8]
CONDENSER					
Total Face Area ft ² [m ²]	21.2[2]	47.1[4.4]	47.1[4.4]	94.2[8.8]	94.2[8.8]
Total Air Flow cfm[m ³ /hr]	11500 [19539]	25420 [43189]	25420 [43189]	50840 [86378]	50840 [86378]
No Of Fan	1	2	2	4	4
Motor kW ¹ (Qty)	2.16 (1)	2.24 (2)	2.24 (2)	2.24 (4)	2.24 (4)
Fan FLA , Amp (Qty)	4.0 (1)	4.0 (2)	4.0 (2)	4.0 (4)	4.0 (4)
GENERAL					
Unit Length inches[mm]	67 [1702]	103 [2616]	103 [2616]	116 [2946]	116 [2946]
Unit Width inches[mm]	48 [1220]	52 [1321]	52 [1321]	89 [2261]	89 [2261]
Unit Height inches[mm]	75 [1905]	90 [2286]	90 [2286]	88 [2235]	88 [2235]
Shipping Weight lbs[kg]	1164 [528]	1826 [828]	2006 [910]	3259 [1478]	3485 [1581]
Operating Weight lbs[kg]	1169 [530]	1837 [833]	2021 [917]	3286 [1491]	3520 [1597]
Operating Charge lbs[kg] - MCHX coil	24 [11]	31 [14]	47 [21]	65 [30]	84 [38]

Model ACDSV	060	070	080	090	100
Unit Nominal Capacity TR[kW]	57.9 [203.4]	68.6 [241.0]	81.8 [287.4]	88.9 [312.7]	95.3 [334.9]
Unit Nominal Power Input kW	66.5	81.2	94.7	103.6	103.3
EER	10.4	10.1	10.4	10.3	11.1
COMPRESSOR					
Min. % Unit Capacity	25%	25%	25%	25%	25%
No. Of Refrigerant Circuit	2	2	2	2	2
EVAPORATOR					
Water Connector inches[mm]	2.5[63.5]	2.5[63.5]	2.5[63.5]	2.5[63.5]	2.5[63.5]
Nominal Water Flow USgpm[m ³ /hr]	139 [31.6]	164.7 [37.5]	196.4 [44.7]	213.4 [48.5]	228.8 [52]
Nominal Pressure Drop ft.wg[kPa]	14.4 [42.8]	11.7 [34.9]	13.8 [41.1]	12.9 [38.5]	14.7 [43.7]
Min/Max. Water Flow USgpm[m ³ /hr]	69.5 / 231.6 [15.8 / 52.7]	82.4 / 274.4 [18.8 / 62.4]	98.2 / 327.2 [22.4 / 74.4]	106.7 / 355.6 [24.3 / 80.8]	114.4 / 381.2 [26 / 86.6]
Min/Max. Water Pressure Drop ft.wg[kPa]	4.1 / 36 [12.3 / 107.6]	3.4 / 29.6 [10 / 88.3]	3.9 / 34.9 [11.7 / 104.2]	3.7 / 32.8 [10.9 / 98]	4.2 / 37.2 [12.4 / 111.1]
CONDENSER					
Total Face Area ft ² [m ²]	94.2[8.8]	94.2[8.8]	141.2[13.2]	141.2[13.2]	188.3[17.5]
Total Air Flow cfm[m ³ /hr]	50840 [86378]	50840 [86378]	76260 [129567]	76260 [129567]	101680 [172756]
No Of Fan	4	4	6	6	8
Motor kW ¹ (Qty)	2.24 (4)	2.24 (4)	2.24 (6)	2.24 (6)	2.24 (8)
Fan FLA , Amp (Qty)	4.0 (4)	4.0 (4)	4.0 (6)	4.0 (6)	4.0 (8)
GENERAL					
Unit Length inches[mm]	116 [2946]	116 [2946]	152 [3861]	152 [3861]	190 [4826]
Unit Width inches[mm]	89 [2261]	89 [2261]	89 [2261]	89 [2261]	89 [2261]
Unit Height inches[mm]	88 [2235]	88 [2235]	88 [2235]	88 [2235]	99 [2515]
Shipping Weight lbs[kg]	3514 [1594]	3780 [1715]	4845 [2197]	4892 [2219]	6048 [2743]
Operating Weight lbs[kg]	3555 [1613]	3837 [1740]	4907 [2226]	4964 [2251]	6119 [2776]
Operating Charge lbs[kg] - MCHX coil	102 [47]	109 [49]	130 [59]	147 [67]	178 [81]

Notes:

- The above data are rated in accordance with AHRI Standard 550/590 with following conditions:
Evaporator leaving fluid temperature 44°F with fluid flow rate 2.4 USgpm/ton; ambient temperature at 95°F; evaporator fouling factor 0.0001hr.ft.².°F/Btu
- To consult nearest Dunham-Bush sales office for computer selections other than above operating conditions

SOUND PRESSURE DATA (ACDSV)

Model	Band (Hz)								TOTAL
	63	125	250	500	1K	2K	4K	8K	
STANDARD UNIT									
ACDSV010	22	31	34	43	52	41	46	35	54
ACDSV020	12	23	40	49	49	48	46	34	54
ACDSV030	12	22	40	49	52	48	47	35	56
ACDSV040	15	25	43	52	51	49	46	35	56
ACDSV050	15	25	43	52	53	50	48	36	57
ACDSV060	15	25	43	52	53	50	48	36	57
ACDSV070	15	25	43	53	57	55	49	38	61
ACDSV080	17	27	45	55	57	56	49	39	61
ACDSV090	17	27	45	55	57	55	49	39	61
ACDSV100	18	28	46	56	58	55	49	39	62
COMPRESSOR JACKET ONLY (WITH LN2 OPTION)									
ACDSV010	22	31	34	41	51	41	46	35	53
ACDSV020	12	23	40	49	47	45	41	31	53
ACDSV030	12	22	40	49	49	45	42	31	53
ACDSV040	15	25	43	51	50	47	42	33	55
ACDSV050	15	25	43	52	51	47	44	33	56
ACDSV060	15	25	43	52	51	47	44	33	56
ACDSV070	15	25	43	52	53	51	45	34	57
ACDSV080	17	27	45	54	54	52	45	36	59
ACDSV090	17	27	45	54	55	51	45	35	59
ACDSV100	18	28	46	55	54	52	46	36	59

Note: Unit Sound Pressure Level (Lp) @ 30 FT [10m] (free field), ± 2 dB(A) tolerance.

FLOOR LOADING DIAGRAM (ACDSV)

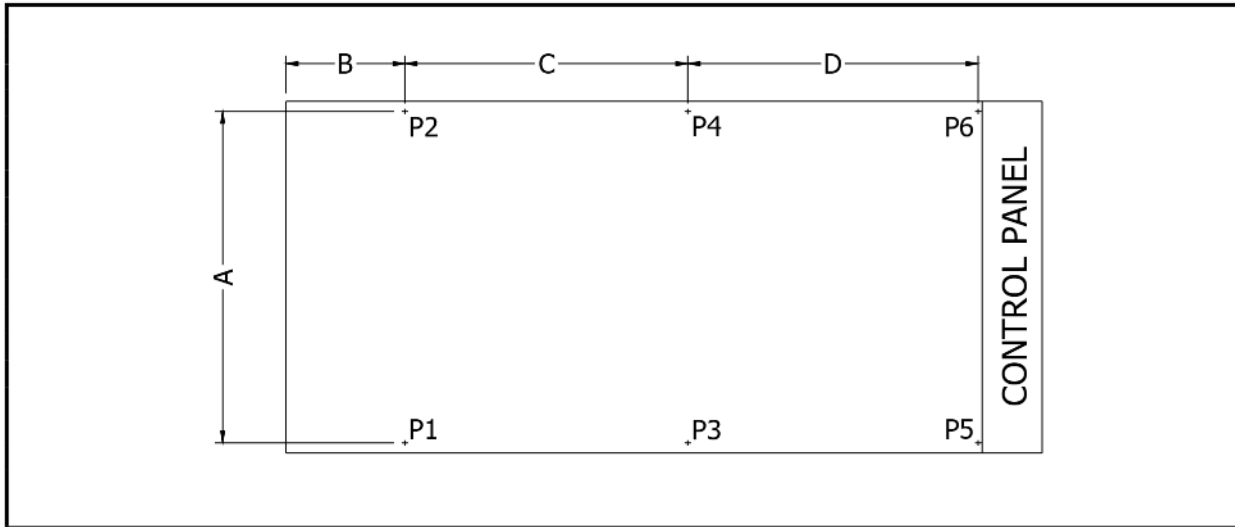

POINT LOAD LOCATION

Model ACDSV	Dimensions – inches [mm]			
	A	B	C	D
10	45 5/8 [1158]	10 1/2 [267]	32 1/2 [826]	-
20	49 1/4 [1251]	21 [533]	58 [1473]	-
30	49 1/4 [1251]	21 [533]	58 [1473]	-
40	85 [2159]	8 1/2 [215]	95 1/4 [2419]	-
50	85 [2159]	8 1/2 [215]	95 1/4 [2419]	-
60	85 [2159]	8 1/2 [215]	95 1/4 [2419]	-
70	85 [2159]	8 1/2 [215]	95 1/4 [2419]	-
80	85 [2159]	13 3/8 [340]	48 3/8 [1230]	73 3/4 [1873]
90	85 [2159]	13 3/8 [340]	48 3/8 [1230]	73 3/4 [1873]
100	83 [2108]	40 3/8 [1026]	60 1/2 [1535]	72 7/8 [1850]

POINT LOAD DATA

Model ACDSV	Loads - lbs [kg]						Total Operating Weight lbs [kg]
	P1	P2	P3	P4	P5	P6	
10	255 [116]	238 [108]	347 [157]	329 [149]	-	-	1169 [530]
20	494 [224]	448 [203]	456 [207]	440 [200]	-	-	1837 [883]
30	548 [249]	514 [233]	493 [224]	465 [211]	-	-	2021 [917]
40	849 [385]	794 [360]	818 [371]	826 [375]	-	-	3286 [1491]
50	924 [419]	858 [389]	865 [392]	874 [396]	-	-	3520 [1597]
60	932 [423]	874 [396]	867 [394]	882 [400]	-	-	3555 [1613]
70	1014 [460]	968 [439]	905 [411]	950 [431]	-	-	3837 [1740]
80	815 [370]	766 [348]	752 [341]	839 [381]	861 [390]	874 [397]	4907 [2226]
90	815 [370]	771 [350]	763 [346]	867 [393]	866 [393]	882 [400]	4964 [2251]
100	1012 [459]	878 [399]	1254 [569]	1243 [564]	867 [394]	865 [393]	6119 [2776]

EVAPORATOR WATER PRESSURE DROP (ACDSV)

1a.) Imperial Units

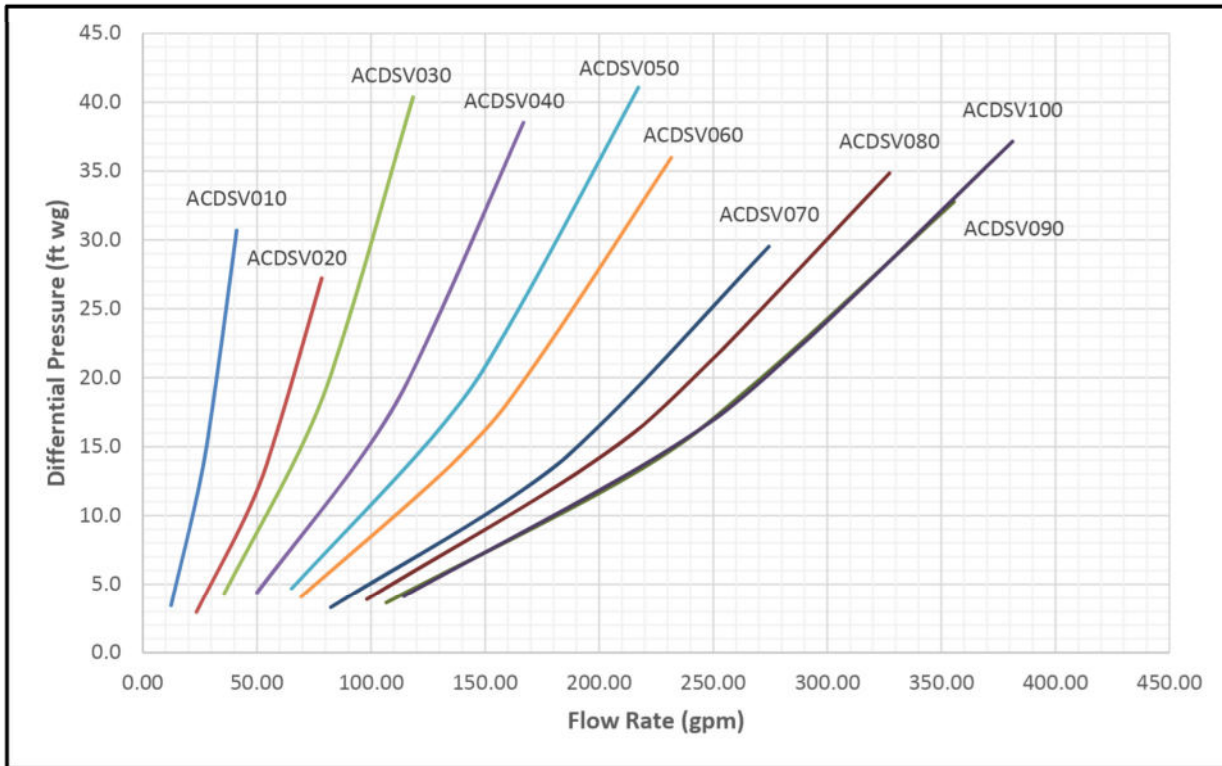

1b.) SI Units

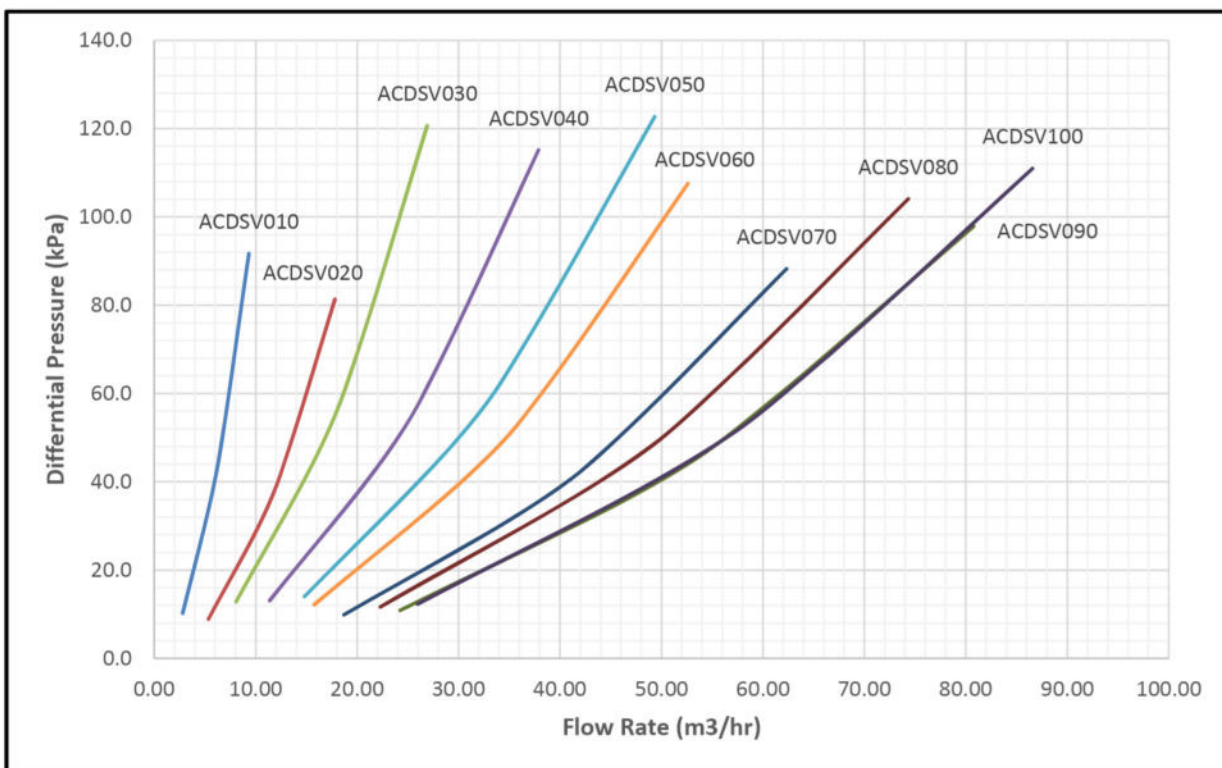

FIELD POWER & CONTROL WIRING SCHEMATIC

TYPICAL FIELD WIRING DIAGRAM

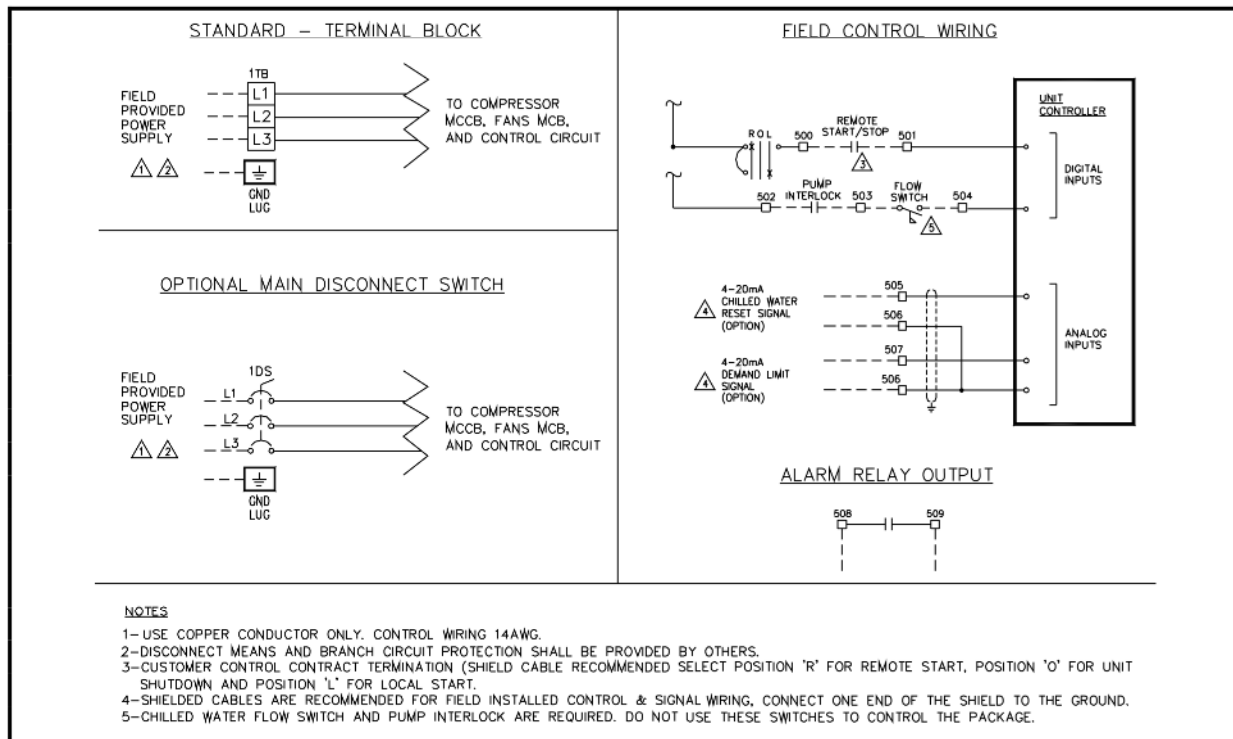

APPLICATION DATA

UNIT DESIGNED OPERATING RANGE

Unit Operating Range – Ambient Temperature ACDS

The units are designed to operate at ambient temperature, 45~115°F [7~46°C]. If the unit requires to be operated at lower ambient temperature, the optional **Low Ambient Operation (LA1)** or **Low Ambient Operation (LA2)** or **Extra Low Ambient Operation (LA3)** shall be incorporated for stable operation.

Operating Limits – Ambient Temperature

Operating Ambient Temperature	SR, standard series	
	Minimum	Maximum
Standard	45°F [7°C]	115°F [46°C]
With LA 1	30°F [-1°C]	115°F [46°C]
With LA 2	0°F [-18°C]	115°F [46°C]
With LA 3	-20°F [-29°C]	115°F [46°C]

ACDSV

The units are designed to operate at ambient temperature, 0~105°F [-18°C ~41°C]. If the unit requires to be operated at lower ambient temperature, the optional **Extra Low Ambient Operation (LA3)** shall be incorporated for stable operation.

Operating Limits – Ambient Temperature

Operating Ambient Temperature	SR, standard series	
	Minimum	Maximum
Standard	0°F [-18°C]	105°F [41°C]
With LA 3	-20°F [-29°C]	105°F [41°C]

If wind velocity in the area is over 5 mph [8 kmph], wind barrier is recommended.

Unit Operating Range – Evaporator Temperature

The unit is designed to deliver chilled fluid temperature within 40~60°F [4.5~15.6°C]. The unit can start and pull down with up to 80°F [27°C] entering-fluid temperature. For sustained operation, it is recommended that the entering fluid temperature not exceed 70°F [21°C].

For unit installation with minimum ambient temperature at 32°F [0°C] or below, **Evaporator Heater (EVH)** option is recommended to prevent freezing of water in evaporator when the chiller is not in operation.

Operating Limits – Leaving Fluid Temperature

Leaving Fluid Temperature	Minimum	Maximum
Standard	40°F [4.5°C]	60°F [15.6°C]
Dual Mode / Low Temp. Operation	20°F [-6.6°C]	60°F [15.6°C]

APPLICATION DATA

EVAPORATOR FLUID CIRCUIT

Wide Range ΔT - Low Flow Applications

Multiple smaller chillers may be applied in series, each providing a portion of the design temperature range typical 10°F [5.5°C] each.

Chilled fluid may be recirculated through the evaporator as shown below to allow the chiller to operate with acceptable flow rates and temperature ranges (Figure 1A).

Figure 1A

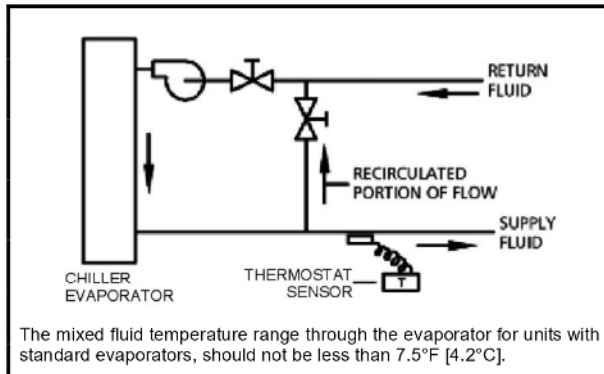

Narrow Range ΔT - High Flow Applications

For Narrow Range ΔT applications, a partial evaporator bypass piping and valve configuration can be used as shown below.

This permits a higher ΔT and lower ΔP (pressure drop) through the evaporator (Figure 1B).

Figure 1B

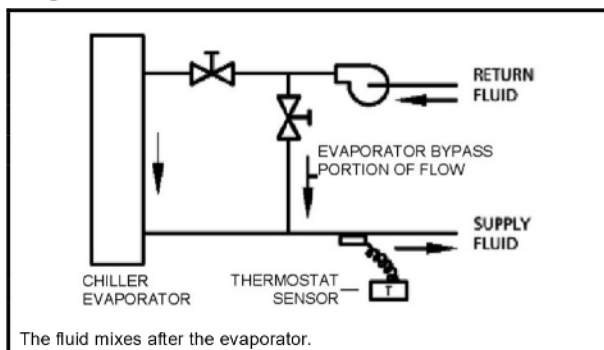

Minimum Chilled Fluid Loop Volume

The evaporator fluid circuit requires a minimum system fluid volume of 3 US gallons per Ton [3.3 liters/ cooling kW] for stable operation. The minimum system fluid volume may increase up to 10 US gallons per Ton [11 liters/ cooling kW] for process cooling, low load applications with small temperature range and/or vastly fluctuating load conditions.

Tanks for System Volume Enhancement

It may be necessary to install a tank in the system to provide sufficient system fluid volume, as shown below. The tank should be baffled and piped for proper fluid mixing to prevent stratification.

Figure 2A

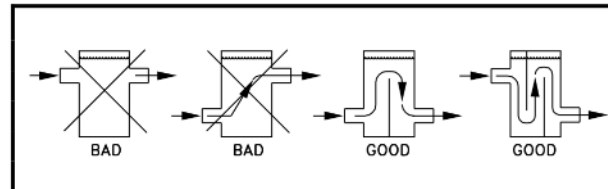

Figure 2B Single Loop System with Storage Tank to Increase Loop Volume

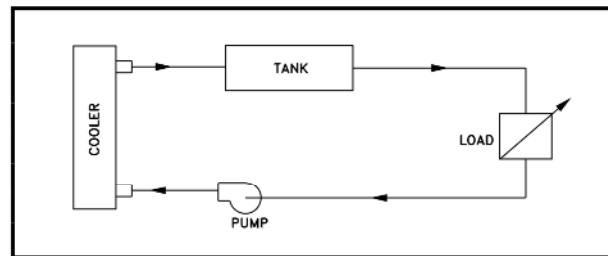
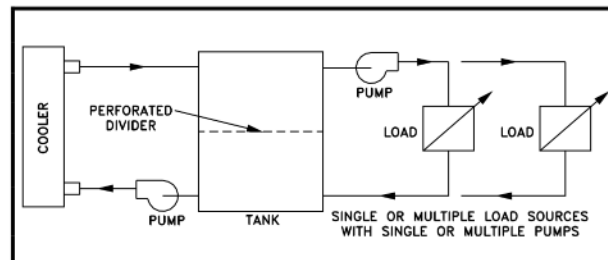

Figure 2C Primary and Secondary Loop Systems are normally used where the secondary system has variable flow and/or multiple loads. See example below.



Multiple Chillers In A Chilled Water System

Where the load is greater than available from one ZEUS ACDSV, where standby capacity is required or the load profile dictates, multiple chillers may be piped in parallel. Units of equal size help to ensure fluid flow balance, but balancing valves ensure balanced flows even with dissimilar sized chillers.

Temperature controller sensors may or may not need to be moved to the common fluid piping depending on the specific application.

Parallel Chiller Applications – Both units operate simultaneously modulating with load variations. Each unit operates independently sensing its own leaving fluid temperature. The set point of each thermostat is set to maintain the desired loading scheme. (Figure 3A)

APPLICATION DATA

Figure 3A

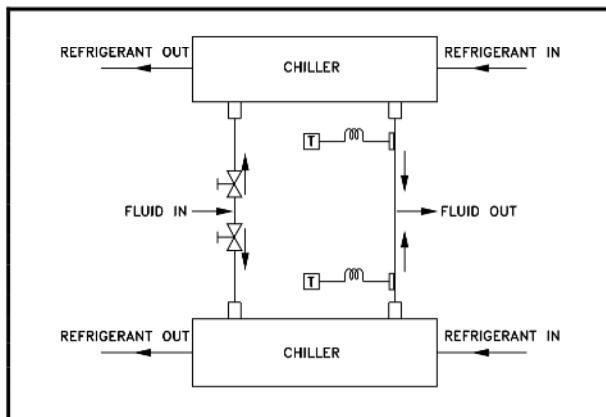

Series Chiller Applications – Where a large temperature range is required (over 25 °F [13.9 °C]), the chiller may be piped in series. In this case the units are controlled independently. The load is progressive by temperature so the chiller selections are critical. (Figure 3B)

Figure 3B

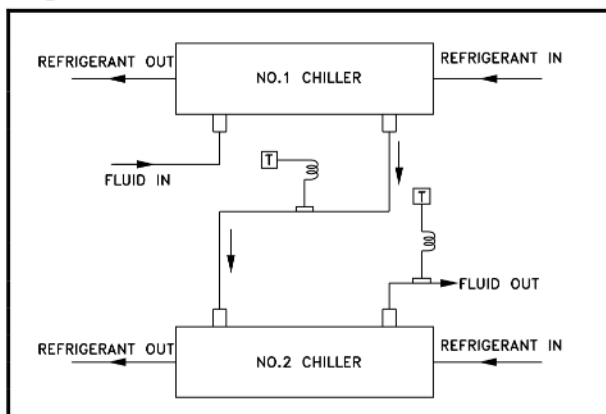

Variable Evaporator Flow

Dunham-Bush chillers are capable for variable evaporator flow system. The chiller may operate to maintain constant leaving fluid temperature with evaporator flow rate changes, with below conditions fulfilled.

- ✦ Evaporator fluid flow rate is within minimum and maximum flow rate of the unit at all time during the operation
- ✦ Rate of flow changed shall not exceeded 10% per minute

Failure to comply with the above conditions will cause problem to the chiller operation and may cause the chiller to shut down.

Water (Fluid) Strainers

It is recommended that 40-mesh strainers be installed in the fluid piping as close to unit evaporator as possible.

Oversizing Chillers

Oversizing of chillers more than 5-10% is not recommended. Oversizing causes energy inefficiency and shortened compressor life due to excessive compressor cycling. Future load requirements may result in temporary oversizing of equipment which will require careful unit selection. It may be better to properly size for the initial load and add another unit later for future increase. The use of multiple units is recommended where operation at minimum load for prolong period is expected and goal control required. Fully loaded equipment operates better and more efficiently than large equipment running at or near minimum capacity.

Hot gas bypass should not be a means to allow oversizing of chillers. Hot gas bypass should only be used where the equipment is sized properly for full load but the minimum load expected is lower than can be achieved by mechanical unloading is less than the minimum unloading step available.

Sound and Vibration

The compressors in units are resiliently, mounted to reduce the transmission of any noise and vibration to the frame.

The compressors are not mounted on springs because extra movement may cause line breakage and refrigerant leaks. Unit isolation helps prevent any remaining sound or vibration from entering the building structure, piping or electrical service.

Glycol Freeze Protection

If the chiller or fluid piping may be exposed to temperatures below freezing, glycol protection is recommended if the water is not drained. The recommended protection is 10°F [5.6°C] below the minimum ambient temperature in the equipment room and around piping. Use only glycol solutions approved for heat exchanger duty. DO NOT use automotive anti-freezing.

If the equipment is being used to supply chilled fluid 38°F [3.3°C] or below, glycol should be used to prevent freeze damage. The freeze protection level should be 15°F [8.3°C] lower than the leaving brine temperature. The use of glycol causes a performance derate as shown below which needs to be included in the unit selection procedure.

Table 1 : Ethylene Glycol

% E. G. By Weight	Freeze Point		C1 Capacity Factor	K1 kW Rate	G1 Flow Factor	P1 P.D. Factor
	°F	°C				
10	26.2	-3.2	0.995	0.998	1.019	1.050
15	22.4	-5.3	0.991	0.997	1.030	1.083
20	17.8	-7.9	0.988	0.996	1.044	1.121
25	12.6	-10.8	0.984	0.995	1.060	1.170
30	6.7	-14.1	0.981	0.994	1.077	1.219
35	0.0	-17.8	0.977	0.992	1.097	1.275
40	-10.0	-23.3	0.973	0.991	1.116	1.331

APPLICATION DATA

Table 2 : Propylene Glycol

% P. G. By Weight	Freeze Point		C2 Capacity Factor	K2 kW Rate	G2 Flow Factor	P2 P.D. Factor
	°F	°C				
10	26.1	-3.3	0.988	0.994	1.005	1.019
15	22.8	-5.1	0.984	0.992	1.008	1.031
20	19.1	-7.2	0.978	0.990	1.010	1.051
25	14.5	-9.7	0.970	0.988	1.015	1.081
30	8.9	-12.8	0.962	0.986	1.021	1.120

Table 3 : Correction Factor - Elevation

Elevation above Sea Level		Capacity Correction Factor	kW Correction Factor
Feet [m]	Meters Factor		
0	0	1.00	1.00
2000	600	0.99	1.01
4000	1200	0.98	1.02
6000	1800	0.97	1.03

Table 4 : Correction Factor - FF

Fouling Factor		Capacity Correction Factor	kW Correction Factor
Hr.ft ² .°F/BTU	m ² .°C/kW		
0.0001	0.018	1.000	1.000
0.00025	0.044	0.993	0.997
0.00050	0.088	0.978	0.990
0.00100	0.176	0.951	0.978

Note: P.D. – Pressure drop across evaporator

Design Requirements

The following design requirements must be known in order to select a packaged chiller.

- *1) Required cooling capacity in TR [kW].
- 2) Evaporator outlet fluid temperature °F [°C].
- *3) USgpm of chilled fluid to be circulated.
- *4) Chilled fluid cooling range (fluid in °F[°C]- fluid outlet °F[°C])
- 5) Design ambient temperature °F[°C].
- 6) Electrical power characteristics.
- 7) Special codes (local, state or national codes) with which unit must comply

*Any 2 out of 3 must be known

EXAMPLE

Select an air cooled packaged chiller for the following conditions:

Cooling Capacity :	75 TR [263.7kW]
Chilled Water In/Out Temperature :	54/44°F [12.2/6.7°C]
Design ambient temperature :	95°F [35°C]
Minimum operating ambient :	+20°F [-6.7°C].
Altitude :	2000 feet [609.6m]
Evaporator fouling factor :	0.0005 Hr.ft ² .°F/Btu
Electrical characteristics :	460V/3/60Hz with single power connection.

Step 1- Unit Selection

For 2000 feet [609.6m] elevation divide the specified tonnage by the capacity correction factor from Table 3.

$$\frac{75 \text{ TR}}{0.99} = 75.8 \text{ TR}$$

For 0.0005 Hr.ft².°F/Btu fouling factor divide the required tonnage at 2000 feet [609.6m] by the fouling correction factor from Table 4.

$$\frac{75.8 \text{ TR}}{0.978} = 77.5 \text{ TR}$$

Entering the capacity data and we see that an ZEUS ACDSV-E 080 unit for water at sea level has a capacity of 81.8 TR, drawing 81.2 compressor kW. The kW correction factors from Table 3 and 4 will be applied to the compressor kW below. For the conditions specified, the unit will do:

$$\begin{aligned} \text{Capacity} &= 81.8 \times 0.99 \times 0.978 = 79.2 \text{ TR} \\ \text{Compressor kW} &= 81.2 \times 1.01 \times 0.99 \\ &= 81.2 \text{ kW} \end{aligned}$$

Step 2- Evaporator USgpm and Pressure Drop

$$\begin{aligned} \text{USgpm} &= \frac{\text{Specified TR} \times 24}{\text{Cooling Range}} = \frac{75 \times 24}{10} \\ &= 180 \text{ USgpm [40.9m}^3\text{/hr]} \end{aligned}$$

Step 3- Chilled Fluid Pump Selection

To the pressure drop calculated in Step 2, add the pressure drop through the chilled fluid loop piping, valves and equipment. This will be the foundation of your pump selection criteria.

GUIDE SPECIFICATIONS

1.0 GENERAL

1.1 Work Included

Provide complete electrically or microcomputer-controlled air cooled chiller utilizing single or tandem scroll compressor sets suitable for outdoor installation. Contractor shall furnish and install chillers as shown and scheduled on the drawings. Units shall be installed in accordance with this specification.

1.2 Quality Assurance

- A. Unit shall be rated in accordance with AHRI Standard 550/590-2020.
- B. Unit construction shall be designed to conform to ANSI/ASHRAE 15 latest version safety standards, NEC (USA), and ASME (USA) applicable codes.
- C. Unit efficiency shall meet or exceed ASHRAE Standard 90.1 (2019).
- D. Unit shall have cETL (USA) and (Canadian) approval.
- E. The unit shall be fully tested at the factory.

1.3 Design Base

The construction drawings indicate a system based on a selected manufacturer of equipment and the design data available to the Engineer during construction document preparation. Electrical services, size, configuration and space allocations are consistent with that manufacturer's recommendations and requirements.

Other listed or approved manufacturers are encouraged to provide equipment on this project; however, it shall be the Contractor and/or Supplier's responsibility to assure the equipment is consistent with the design base. No compensation shall be approved for revisions required by the design base or other manufacturers for any different services, space, clearances, etc.

1.4 Delivery and Handling

The unit shall be delivered to the job site completely assembled and charged with R454B refrigerant and oil by the manufacturer.

Comply with the manufacturer's instruction for rigging and handling.

1.5 Maintenance

Maintenance of the chillers shall be the responsibility of the owner and performed in accordance with the manufacturer's instructions.

2.0 PRODUCTS

2.1 Single or Tandem Scroll Compressor Air Cooled Water Chillers

2.2 Acceptable Manufacturers

- A. Dunham-Bush
- B. (Approved equal)

2.3 General

Furnish and install as shown on the plans, air cooled single or tandem scroll compressor liquid chillers. Units shall be Dunham-Bush Model air cooled chiller or equal.

Environment friendly refrigerant with Zero ODP (Ozone Depletion Potential) and a low global-warming potential (GWP) shall be used. Refrigerant with non-Zero ODP shall not be accepted.

The units are to be completely factory assembled and wired in a single package complete with single or tandem scroll compressors, evaporator, condenser, starting control with safety and operating controls. The unit shall be given a complete factory operating and control sequence test under load conditions and shall be shipped with full operating charge of R454B and full oil charge.

2.4 Performance

The units shall be furnished as shown on capacity schedules and drawings. Unit performance shall be rated in accordance with AHRI Standard 550/590-2020.

ACDS unit shall be designed to operate safely and stably to provide chilled fluid temperature 40~60 °F [4.5~18°C], ambient temperature 45~115°F [7~46°C].

ACDSV unit shall be designed to operate safely and stably to provide chilled fluid temperature 40~60 °F [4.5~18°C], ambient temperature 0~105°F [-18~41°C].

Optional Dual mode operation or low temperature operation shall be available to allow unit operation down to 20°F [-6.6°C] for leaving chilled fluid temperature.

Optional low ambient kit shall be available to allow unit operation with ambient temperature down to -20°F [-29 °C].

2.5 Construction

The unit shall be designed for maximum corrosion protection being of heavy gauge, galvanized steel construction with baked on powder coating.

2.6 Evaporator

ACDS010-150 & ACDSV010-100 evaporator shall be brazed plate heat exchanger for compact foot print while ACDS165-180, evaporator shall be ASME shell & tube. Fluid side design working pressure shall be minimum 150psig [10bar] and refrigerant side design working pressure shall be minimum 450psig [31bar]. Evaporator shall be insulated with 1 inch [25mm] closed-cell insulation.

For 575V/3ph/60Hz ACDS010-150 models, standard units are with ASME brazed plate heat exchanger.

2.7 Condenser

The condenser shall be finned tube coil (Aluminum fin, Copper tubes) or Microchannel coil. Integral sub-cooling circuits shall be incorporated into the coil. Condenser divider baffles shall fully separate each condenser fan section to control the airflow to maintain proper head pressure control.

GUIDE SPECIFICATIONS

2.8 Fans

The fans shall be heavy duty, aluminum blade, direct drive propeller type. Motors shall be three phase type with internal overloads and EC respectively for ACDS and ACDSV. Fan blades shall be statically and dynamically balanced. Fan motor shall be rated minimum IP54 for outdoor application.

2.9 Compressor

The compressors shall be Single or Tandem Scroll. Tandem scroll compressors shall be with suction and discharge manifold, with oil and gas equalization provided. All compressors shall be direct drive with an integral two-pole hermetic motor. A dust-proof terminal box, located in an accessible location on the compressor, shall contain all connection terminals.

The compressors shall be fitted with a crankcase heater or sump heater, and oil sight glass. Inverter compressor to equip with oil level switch and sometime accompanied by oil solenoid coil.

2.10 Capacity Control

Compressor cycling shall be utilized to match the demand requirement of the system. The factory supplied temperature controller shall cycle compressors in response to leaving fluid temperature and maintain fluid temperature within 3.0°F [1.7°C] of setpoint. This system is to provide precise and stable control of supply fluid temperature over the complete range of operating conditions. It shall be capable of maintaining a system capacity range from 100% to _____% at specified conditions without hot gas bypass.

2.11 Refrigerant Circuit

(One compressor) (Two compressors) (Four compressors) (Six compressors) shall be used with a direct expansion evaporator.

Insulate evaporator and other cold surfaces as required to prevent condensation at ambient conditions of 75°F RH of 90°F [32°C] dry bulb with no air movement.

Each refrigerant circuit shall include expansion valve, sight glass, moisture indicator, replaceable core filter-drier or in-line filter drier, liquid line shut off valves, and charging port.

2.12 Control Center

Control Center shall be fully enclosed in a steel, baked powder coated control panel with hinged access doors. Dual compartments, separating safety and operating controls from the power controls, are to be provided.

A. Controls shall include:

1. Compressor protection, solid state, thermal sensing overloads, with manual reset.
2. High refrigerant discharge pressure, manual reset.
3. Low refrigerant suction pressure protection
4. Freeze protection, manual reset.
5. Chilled fluid flow switch interlock.
6. Separate power terminal blocks for main power and 115V AC chiller heater power.

7. Compressor starter including current sensing overload protection.
8. Factory installed controller including integral anti-recycle protection.
9. Complete labeling of all control components.
10. Numbered terminal strips and labeled components for easier wire tracing.
11. Condenser fan cycling control

Intelligent controller shall be offered for complete unit monitoring and control. For any type of controller is offered, items listed at 2.12.A shall be complied.

Intelligent microprocessor controller shall be provided for complete monitoring and control of the unit. The unit algorithm program and operating parameters shall be stored in FLASH-MEMORY that does not require a back-up battery. Microprocessor controller which requires back up battery shall not be accepted.

The controller shall be equipped with a user friendly semi-graphical display panel. All description shall be spelled out in English. The display panel shall have dedicated keys for access to each individual menu/function, such as input status, compressor status, alarm history, real time clock, login and etc. The controller shall provide minimum three levels of access to prevent unauthorized access to control setpoints and parameters.

The microprocessor controller shall provide as a minimum the following features and options.

1. Control Functions:
 - a. i) Staging of compressors to achieve precise control of leaving water. (ACDS)
 - ii) Staging and modulating of compressors to achieve precise control of leaving water. (ACDSV)
 - b. i) Switching of condenser fans to control head pressure. (ACDS)
 - ii) Staging and modulating of condenser fans on the air cooled condenser to control head pressure. (ACDSV)
 - c. Anti-recycle timer
 - d. 7 days weekly schedules for machine control.
 - e. Automatic pump-down before unit shut down; and pump-out during unit start-up
 - f. Proactive control of compressor cycling to help prevent high pressure or low pressure trips.
 - g. Proactive control providing safeties for high pressure, low pressure and freeze protection, to eliminate nuisance trips.
 - h. Proactive compressor staging to eliminate overloading during start-up to reduce compressor cycling.
 - i. Hotgas bypass control [option].
2. Unit Protection:
 - a. Low pressure cutout with Proactive safety.
 - b. High pressure cutout with Proactive safety.
 - c. Automatic re-start from power outage with event posting.
 - d. Evaporator freeze protection.
 - e. Sensor error.

GUIDE SPECIFICATIONS

- f. Pump down -pump out failure.
- g. Compressor starter error lockoff.
- 3. Readouts:
 - a. Entering liquid temperature (If applicable)
 - b. Leaving liquid temperature.
 - c. Evaporator suction pressure
 - d. Condenser discharge pressure
 - e. Unit control Status.
 - f. Water flow switch status.
 - g. Compressor status.
 - h. Liquid line solenoid control status (If applicable)
 - i. Condenser fan control status.
 - j. Unit alarm status.
- 4. Setpoints with proper authorization:
 - a. Leaving chilled water temperature setpoint
 - b. Leaving chilled water temperature control zone
 - c. Evaporator freeze protection alarm setpoint
 - d. Fan staging control setpoints
 - e. Pump down control setpoints
 - f. Low suction pressure safety setpoints
 - g. High discharge pressure safety setpoints
- 5. Alarm history
 - a. 99 of most recent alarms shall be retained in Alarm History with below information:
 - i. Date and time the alarm was triggered with description on the alarm triggered
 - ii. Suction pressure
 - iii. Discharge pressure
 - iv. Evaporator leaving chilled water temperature
- 6. Group Control and Remote monitoring capabilities
 - a. Building Management System (BMS) Interface.
Controller shall be equipped with factory supplied and installed communication card [option] for interfacing with Building Management System (BMS).
 - b. Various communication protocols as below shall be offered.
 - i. Modbus RTU RS485
 - ii. Modbus TCP/IP
 - iii. BACnet TCP/IP
 - iv. BACnet MS/TP
 - v. LonWorks

2.13 Options and Accessories

1. **Copper Fin Copper Tube Condenser Coil (COP)** for corrosion protection
2. **Aluminum Fin and Tube Condenser Coil with DB-COAT (DB-COAT-AL)** – the post-coated solution for Aluminium Fin and Copper Tube condenser coil to provide extensive corrosion protection for harsh environment.
3. **Copper Fin and Tube Condenser Coil with DB-COAT (DB-COAT-CU)** – the post-coated solution for Copper Fin and Copper Tube condenser coil to provide extensive corrosion protection for harsh environment.

4.
 - i. **Microchannel Coil (MCHX)** shall be supplied as ACDS020-180 condenser coil
 - ii. **Aluminium Fin Copper Tube Condenser Coil (AL)** shall be supplied as ACDSV020-100 condenser coil. Coil constructed of seamless inner grooved copper tubes expanded into die-formed aluminium slit fins.
5. **Microchannel Condenser E-Coating (MCHX-E)** which provides an enhanced anti-corrosion protective layer for microchannel coil for harsh environment. (applicable for model ACDS020-180 & ACDSV020 – 100)
6. **Electronic Expansion Valve (EEV)** shall be supplied for model ACDS010-090 to further optimize unit performance and efficiency.
7. **Suction Isolation Valve (SIV)** shall be provided at suction refrigerant line for service convenience.
8. **Hot Gas Bypass (HGBP)** – To maintain unit operation below minimum unloaded capacity.
9. **Pressure Gauges (GAG)** – Pressure gauges shall be installed on the unit to display suction and discharge pressure readings.
10. **Low Ambient Operation (LA1)** – To allow ACDS unit operation down to 30°F [-1°C] ambient operation. Standard offered for ACDS-V.
11. **Low Ambient Operation (LA2)** – To allow ACDS unit operation down to 0°F [-18°C] ambient operation. Standard offered for ACDS-V.
12. **Extreme Low Ambient Operation (LA3)** – To allow the unit operation down to -20°F [-29°C] ambient temperature.
13. **Shell-And-Tube Evaporator (ST2)** – Shell-And-Tube vessel shall be supplied as ACDS010-150 and ACDSV010-100 evaporator in lieu of brazed plate heat exchanger. Shell-And-Tube evaporator shall be constructed in accordance with ASME and mechanically cleanable with removable water heads.
14. **Low Noise Fan (LNF)** – Low noise fans are incorporated to reduce ACDS unit sound level. Standard offered for ACDS-V.
15. **Protective Panels for Condenser Coil (LUV)** – Wire-mesh panels to protect condenser coil faces and prevent unauthorized access to it.
16. **Hail Guard (HGRD)** – Full casing height painted galvanized steel panels to provide hail protection, general mechanical security and aesthetics appeal to the unit.
17. **Rubber-in-shear Isolators (RIS)** – To reduce the transmission of vibration, produced by rotating mechanical equipment or water flow, into or within a building structure.
18. **Spring Vibration Isolators (SPG)** – Spring isolator with 1" [25.4mm] deflection shall be supplied to reduce the transmission of vibration, produced by rotating mechanical equipment or water flow, into or within a building structure.
19. **Water Flow Switch (WFS4)** – Water Flow Switch NEMA4 shall be shipped loose and installed at evaporator outlet piping at field as safety interlock to evaporator water flow status.

GUIDE SPECIFICATIONS

- 20. **Flanged Cooler Water Connectors (FCWC)** shall be supplied in lieu of Victaulic coupling.
- 21. **Compressor Acoustic Jacket (LN2)** – Compressor acoustic jackets shall be added to further reduce unit sound level.
- 22. **Evaporator Heater (EVH)** – Strip heater shall be wrapped around the evaporator to provide anti-freeze protection down to -20°F[-28.9°C] ambient temperature.
- 23. **Double Thick Insulation (DPHE)** – Plate heat exchanger evaporator shall be insulated with double thick 2" [50mm] closed cell insulation for extra resistance to condensation.
- 24. **Double Thick Insulation (DSNT)** – Shell & Tube evaporator shall be insulated with double thick 2" [50mm] closed cell insulation for extra resistance to condensation.
- 25. **Pressure Differential Transducer (PDT)** – Pressure Differential Transducer shall be supplied to detect fluid flow
- 26. **Convenience Outlet (CON)** – 115Vac GFCI convenience outlet with female receptacle shall be supplied.
- 27. **IP55 Control Panel (IP55)** – Control panel with IP55 rating shall be supplied for harsh working environment.
- 28. **Digital Power Meter (DPM)** - for voltage / current indication, located inside the control panel.
- 29. **Soft-starter For Fixed Speed Compressor Motors (SST)** – Solid State starter comes with bypass contactor shall be furnished to reduced mechanical stress and inrush current at compressor start-up.
- 30. **Ground Fault Interrupt (GFI)** – Provides equipment with ground fault protection.
- 31. **Weather Proof Alarm (WPA)** – Weather proof audible alarm shall be supplied for common alarm fault alert.
- 32. **Main Incoming Isolator (MII)** – Non-fused disconnect switch with external lockable handle shall be furnished to isolate unit main incoming power supply for servicing.
- 33. **BMS Communication (BMS)** – Communication protocol shall be provided with add-on communication card;
 - i. Modbus RTU RS485
 - ii. Modbus TCP/IP
 - iii. BACnet TCP/IP
 - iv. BACnet MS/TP
 - vi. LonWorks
- 34. **Chilled Water Reset (RFTR)** – To allow controlled temperature setpoint to be reset by a 4-20Ma signal from BAS.
- 35. **Demand Limit (AMPL)** – To limit maximum running compressors by a 4-20Ma signal from BAS.

- ← 36. **ASME Brazed Plate Heat Exchanger (PHE-ASME)** – ASME brazed plate heat exchanger shall be supplied as ACDS010-150 and ACDS010-100 evaporator in lieu of brazed plate heat exchanger.

3.0 EXECUTION

3.1 Installation Work By Mechanical Contractor

- A. Install on a flat surface level within 1/16 inches [1.6mm] and of sufficient strength to support concentrated loading. Place vibration isolators under the unit.
- B. Assemble and install all components furnished loose by manufacturer as recommended by the manufacturer's literature.
- C. Complete all fluid and electrical connections to unit, fluid circuits and electrical circuits are serviceable.
- D. Provide and install valves in fluid piping upstream and downstream of the evaporator to provide means of isolating shells for maintenance and to balance and trim system.
- E. Provide soft sound and vibration eliminator connections to the evaporator fluid inlet and outlet as well as electrical connections to the unit.
- F. Interlock chillers through a flow switch in the chilled fluid line to the chilled fluid pump to ensure the unit can operate only when fluid flow is established.
- G. Furnish and install taps for thermometers and pressure gauges in fluid piping adjacent to inlet and outlet connections of the evaporator.
- H. Provide and install drain valves with capped hose ends to each fluid box.
- I. Install vent cocks to each fluid box.

3.2 Work By Temperature Control Contractor

- A. Furnish interlock wiring per manufacturer's recommendations and install loose control components furnished by chiller manufacturer.

3.3 Work By Electrical Contractor

- A. Furnish power wiring to chiller control panel and obtain required code approval.
- B. Furnish and install approved disconnect switch and short circuit protection and short circuit protection.

