



# ACHELOUS

Variable Speed Air Cooled Screw Chillers

AVX-B 50/60Hz

Cooling Capacity: 115 to 470 TR (406 to 1656 kW)



# DUNHAM-BUSH®

Products that perform...By people who care

# INTRODUCTION

For more than 100 years, Dunham-Bush has focused on innovative product development. Today, we provide a full portfolio of HVAC/R products from Fan Coil Units to large centrifugal chillers as well as many other innovative green solutions. Our commitment to innovation, matched with an aggressive attitude toward growth, makes Dunham-Bush a leader in global markets. Our product development is tailored to meet the specific needs of customers, building-by-building, country-by-country and region-by-region. No other HVAC/R manufacturer takes this approach to meeting your performance expectations.

The Dunham-Bush name is synonymous worldwide with the Rotary Screw Compressor Chillers technology. With over 45 years of proven experience and track records in manufacturing and installation of Rotary Screw Compressors and chillers, thousands of our Chillers have clocked more than 100,000 operating hours without any compressor tear-out or overhaul! As a pioneer and industry leader in the Rotary Screw compressor technology for HVAC/R systems, Dunham-Bush now introduces the Air Cooled Rotary Screw Flooded Chillers with unsurpassed performance and reliability.

**ACHELOUS**, AVX-B Variable Speed Air Cooled Screw Chillers, have a cooling capacity range from 115 to 470 TR [406 to 1656 kW] using environmentally sound R134a refrigerant. The entire product line features high energy efficiency, installation ease, control flexibility, high reliability and advanced Vision 2020i controller. The AVX-B series are certified to AHRI Standard 550/590 and meets / exceeded ASHRAE Standard 90.1 requirements.

# TABLE OF CONTENT

Page No	Page No		
Introduction .....	2	Sound Pressure Data .....	12
Nomenclature.....	2	Dimensional Data .....	13
General Characteristics .....	3	Floor Loading Diagram.....	17
Unit Features .....	3	Field Power & Control Wiring Schematic.....	18
Options And Accessories.....	6	Application Data .....	19
Operating Benefits .....	8	Minimum Clearance Requirements .....	22
Physical Specifications .....	10	Guide Specifications.....	23
Electrical Data.....	11		

# NOMENCLATURE

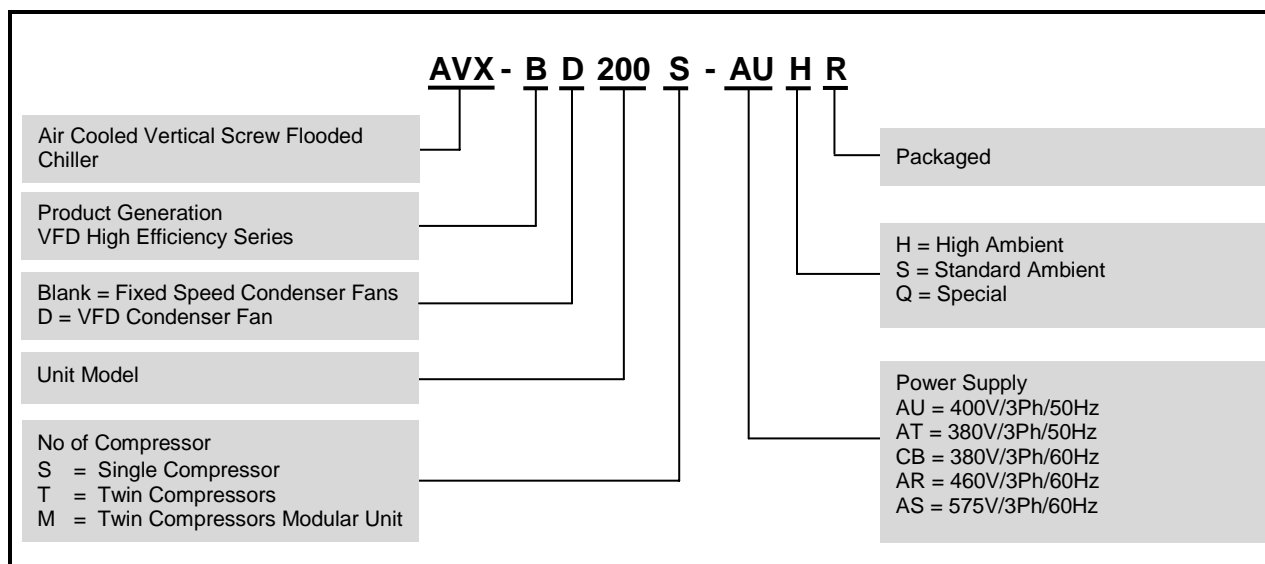

# GENERAL CHARACTERISTICS

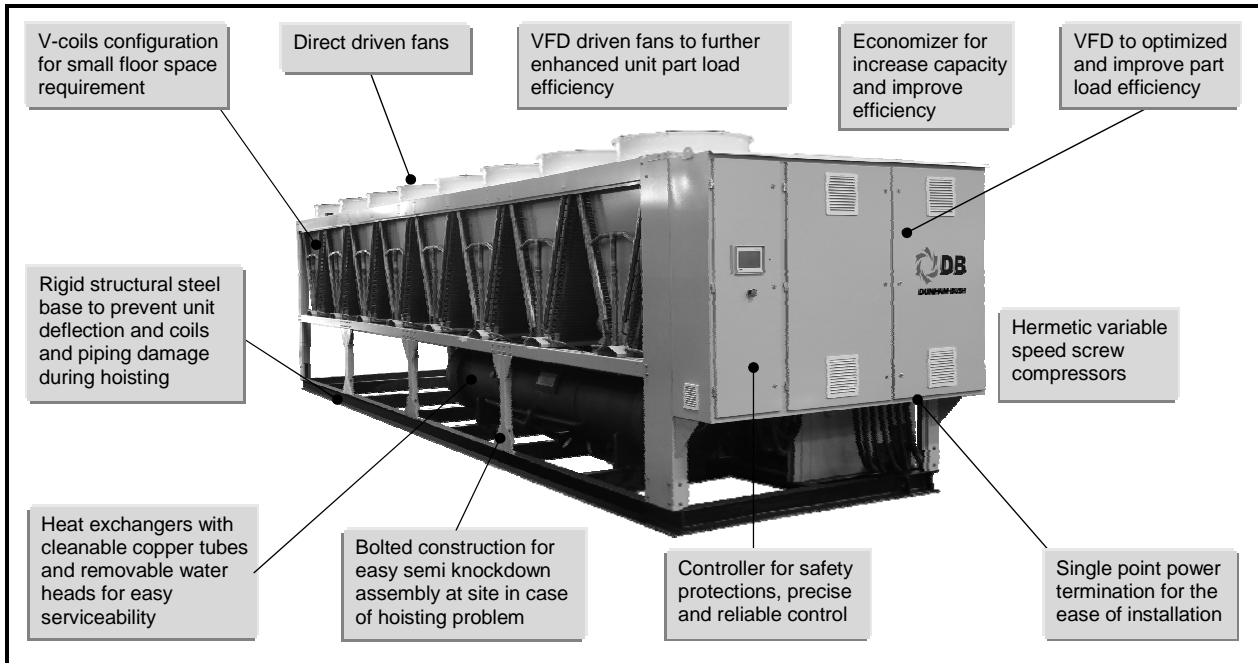

# UNIT FEATURES

## GENERAL

- ✦ 16 models rated in accordance with AHRI standard conditions
- ✦ Built-in with Variable Frequency Drive (VFD) for compressor, no starter is required
- ✦ Direct-drive, twin screws compressors driven by VFD offers superior part load energy efficiency
- ✦ Great improvement on Integrated Part Load Value (IPLV), which rated in accordance with AHRI Standards 550/590-2011
- ✦ Multiple compressors models with independent refrigerant system per compressor provide redundancy, and superior part load efficiency
- ✦ The unit is designed to operates with R134a, the environment friendly refrigerant with zero **ODP** (Ozone Depletion Potential)
- ✦ Substantially reduced operating sound level, especially at part-load operation; sound level can be reduced up to 12 dB(A) for twin compressors models at part load operation
- ✦ Standard unit operating ambient temperature, 45~125°F [7~52°C], for high ambient series
- ✦ Standard unit operating ambient temperature, 45~115°F [7~46°C], for standard ambient series
- ✦ Units are ETL listed for North America and Canada regions.

## Compressor

- ✦ New generation of Dunham-Bush MSC Vertical Screw Compressors with Unique Patented Twin Screw compressor technology, offers further improved reliability and stability, with lower sound level

- ✦ Optimized oil management with up to 2 integral oil separators. Multi-layered mesh element effectively separates oil from the gas stream
- ✦ No external oil pump required
- ✦ Patented screw profile design which is specially made for R134a application, to assure operation at highest efficiencies
- ✦ Optimized volume ratio, VI port position and geometry for best efficiency
- ✦ Hermetic design eliminates casing leakage, with no requirement for internal parts service, no periodic compressor tear down and overhaul
- ✦ Direct driven design eliminates gear set; improve efficiency and reliability
- ✦ Discharge service valves is provided to each compressor for the ease of servicing

## Evaporator

- ✦ Shell-and-tube flooded type heat exchanger
- ✦ Integral finned copper tubes to maximized heat transfer area
- ✦ Cleanable copper tubes for maintaining high efficiency
- ✦ Removable water heads for easy service
- ✦ Victaulic groove water connection comply to ANSI/AWWA C-606
- ✦ Standard with 1" thick closed cell insulation
- ✦ Standard relief valve(s) – 3/4" [19mm] FPT
- ✦ Pressure test up to 220psig for refrigerant side, and 195psig for water side
- ✦ Isolation valves for refrigerant filter dryers are provided to allow filter core replacement without pump down the chiller. This greatly improve the servicing expenses and time

# UNIT FEATURES

## Condenser and Fans

- ✿ Constructed with seamless inner-grooved copper tubes expanded into die-formed aluminum slit fins in staggered configuration
- ✿ Leak and pressure test at 450psig [31bar]
- ✿ “V” coil design to increases condensing surface area to maximized heat rejection
- ✿ “V” coils arrangement with internal baffle for fan cycling and staging
- ✿ IP55, Class “F” insulation fan motors for outdoor applications

## Variable Speed Drive (VSD)

- ✿ Regulates motor speed to matched with capacity demand
- ✿ Offers faster response on load changed, and precise capacity control
- ✿ Soft start the compressor to minimized compressor inrush current to virtually, zero inrush current
- ✿ Maintain displacement power factor at minimum 0.95 at all operating conditions
- ✿ VFD on condenser fans to further improve part load energy efficiency as option

## Electronic Expansion Valve

- ✿ Advanced electronic expansion valve (EEV) is used for precise control of liquid refrigerant flow into the evaporator
- ✿ Evaporation of liquid refrigerant in evaporator is controlled at precise level for optimum performance

## Economizer

- ✿ The economizer circuit consists of plate type heat exchanger, expansion valve and solenoid valve
- ✿ Liquid refrigerant is sub-cooled at economizer before entering the evaporator; the flash refrigerant from economizer is fed into vapor injection port of the compressor
- ✿ The economizer increased cooling capacity by means of the sub-cooling
- ✿ Cooling capacity is increased significantly with marginal increases in kW-input, thus, unit EER is improved

## Control Panel

- ✿ Weather tight electrical enclosure fabricated by heavy gauge sheet steel with powder coated baked finishing
- ✿ Single point power connection for all models, except models AVX-B 470M which is modular units with dual power connection points as standard
- ✿ Circuit breaker for compressors and condenser fan motors
- ✿ Step down transformer for power supply to control circuit

- ✿ Main power supply monitoring module. Protection on under or over voltage, phase reversal, phase losses and imbalance
- ✿ Unit mounted Remote/Off/Local (R/O/L) selector, an operation and servicing friendly feature
- ✿ Overload protection relay for compressors
- ✿ Vision 2020i – the state-of-art Dunham-Bush proactive advanced controller that adapts to any abnormal operating conditions and for safety protections
- ✿ Chilled water pump control
- ✿ Emergency push stop button

## VISION 2020i CONTROLLER



Vision 2020i a flexible and advance programmable microprocessor controller designed specifically for the application and precise control of Dunham-Bush Rotary Screw compressor chillers.

The controller is provided with a set of terminals that connect to various devices such as temperature sensors, pressure and current transducers, solenoid valves, compressors and fans starters, control relays, etc.

The unit algorithm program and operating parameters are stored in FLASH-MEMORY that does not require a back-up battery. The program can be loaded through PC or programming key.

Vision 2020i controller is equipped with a user friendly DBG5 graphical touch screen color display panel. DBG5 display terminal has dedicated touch keys that provides easy access to the unit operating conditions, control set points, trend graphs and alarm histories.

Each unit's controller can be configured and connected to the local DBLAN network that allows multiple units sequencing control without additional hardware. The DBLAN is local area network made up of several chillers' controller.

# UNIT FEATURES

---

## Display and User Terminal

Vision 2020i controller is designed to work with the DBG5 terminal display, a 7" TFT, 65k colors, LED backlight touch screen graphical display panel. DBG5 terminal display allows carrying out all program operations. The user terminal allows displaying the unit working conditions, compressor run times, alarm history and modifying the parameters. The display also has an automatically self-test of the controller on system start-up. Multiple messages will be displayed by automatically scrolling from each message to the next. All of these messages are spelled out in English language on the display terminal.

Touch keys on DBG5 graphical display panel allow user to access information and settings, based on security level of the password. For more detail operation of the Display Terminal, please refer to the Unit Operation Manual.

Easily accessible measurements include:

- ✿ Leaving and entering chilled water temperature
- ✿ Rate of Change for leaving chilled water temperature
- ✿ Evaporator and condenser pressure
- ✿ Compressor discharge temperature and superheat
- ✿ Ambient temperature
- ✿ Current drawn by each compressor
- ✿ Compressor operating frequency
- ✿ Compressor capacity (percentage of FLA, Full Load Amps)
- ✿ Run hours of each compressor
- ✿ Number of starts of each compressor
- ✿ Electronic Expansion Valve (EEV) Opening Percentage
- ✿ Compressors and condenser fans motors status
- ✿ Oil Level Status, Water Flow Switch Status, Remote Start/Stop Command Status
- ✿ Trend graph of leaving chilled water temperature

## Capacity Control

Leaving chilled water temperature control is accomplished by entering the water temperature setpoint and placing the controller in automatic control. AVX-B chillers visualized precise capacity control thanks to the VFD controlled, direct driven compressor. Vision 2020i monitors all control functions and regulates compressor motor speed to match closely to the actual building load requirement. This will put the chiller operation at optimum efficiency at all time, and thus, maximized the energy saving of the chiller plant operation.

The compressor ramp (loading) cycle is programmable and may be set for specific building requirements. Remote adjustment of the leaving chilled water setpoint is accomplished either through High Level Interfacing (HLI) via BMS communication, or Low Level Interfacing (LLI) via an external hardwired, 4 to 20mA chilled water reset control signal. Remote reset of compressor current limiting function can be accomplished in a similar fashion.

## System Control

The unit may be started or stopped manually, or through the use of an external signal from a Building Automation System. In addition, the controller may be programmed with seven-day operating cycle or other Dunham-Bush control packages may start and stop the system through inter-connecting wiring.

## System Protection

The following system protection controls will automatically act to ensure system reliability:

- ✿ Low evaporator pressure
- ✿ High condenser pressure
- ✿ Freeze protection
- ✿ Low suction-discharge pressure differential
- ✿ Low compressor oil level
- ✿ Compressor run error
- ✿ Power loss
- ✿ Chilled water flow loss
- ✿ Sensor error
- ✿ Compressor over current
- ✿ Compressor Anti-recycle
- ✿ High motor temperature
- ✿ Compressor overload
- ✿ VFD fault

The controller can retain up to 99 alarm histories complete with time of failure together with data stamping on critical sensor readings in an alarm condition. This tool will aid service technicians in troubleshooting tasks enabling downtime and nuisance trip-outs to be minimized.

## Remote Monitoring And Control (Option)

Dunham-Bush, the leader of HVAC solution provider understands the arising focus on chiller plant performance and optimization. Several solutions as below are offered to the building owner to achieved optimized chiller plant room controls, operation and performance.

### Dunham-Bush Chiller Plant Manager (CPM)

DB Chiller Plant Manager (**CPM**) is a trustworthy and headache-free solution for building owners and users on chiller plant control and automation system. **CPM's** advanced controllers monitor and control equipments in chiller plant such as chillers, primary and secondary chilled water pumps, variable frequency drives (VFD), motorized valves, bypass modulating valves, and etc. Field devices such as flow meters, BTU meters, digital power meters, sensors & transducers can be interfaced with **CPM** via HLI or LLI. CPM controls chillers and pumps sequencing, as well as lead-lag, duty-standby and alarm changeover operations.

**NetVisorPRO** – Monitoring software of **CPM** system which allows system monitoring, historical trending, and alarm logging to be carry out at a PC terminal. Graphical animations on system operation, temperature and flow rate trend graphs, historical data and alarm history logs, settings changes are all available with **NetVisorPRO**.

# UNIT FEATURES

---

Chiller plantroom control and automation by Dunham-Bush **CPM** provides the owners with a chiller system in stable operation, optimized performance and energy efficiency.

## DB-LAN Master Slave Sequencing Control (MSS)

In a chiller system with multiple Dunham-Bush chillers, Vision 2020i controller of each chiller can be connected to the DB-LAN network via a communication bus without additional controller, to enable Master-Slave Sequencing Control of this chiller system. **MSS** will stage in/out chiller in operation to match building required cooling capacity. Chiller Lead-lag, duty-

standby and alarm changeover controls are come with **MSS**, as well as the chilled water pumps control. Each **MSS** DB-LAN network can be connected up to 8 numbers of chillers.

## Building Management System (BMS) Communication

Vision 2020i is able to communicate to BMS through the add-on communication card via various common protocols as:

- ✦ Modbus RTU RS485, ModBus TCP/IP
- ✦ BACnet over IP, MS/TP, or PTP
- ✦ LONworks FTT 10

# OPTIONS AND ACCESSORIES

---

- ✦ **Heat Recovery** – The hot gas desuperheater; a shell-and-tube heat exchanger that reclaims ‘waste’ heat from compressor to produce hot water up to 55°C
- ✦ **Condenser Corrosion Protection** – Copper (CU) fins or Hydrophilic coated fins are provided to give better corrosion protection. **DB-COAT**, the post-coated solution for condenser coil to provide extensive corrosion protection for harsh environment
- ✦ **Hotgas Bypass** – To maintain unit operation below minimum unloaded capacity
- ✦ **Service valve** – Compressor suction service valve is supplied to further isolate the compressor from evaporator
- ✦ **Flanged Semi-hermetic Compressor** – Semi hermetic compressor is available on request
- ✦ **Low Ambient Operation (LA1)**–Variable frequency drive (VFD) is incorporated to the condenser fan motor to allow unit operation down to 14 °F [-10 °C] ambient temperature
- ✦ **Extra Low Ambient Operation (LA2)** – Add-on low ambient kit to allow unit operation down to -20°F [-29°C] ambient temperature  
Note: Please consult factory for LA2 option.
- ✦ **VFD on Condenser Fans** – Condenser fan motors driven by VFD to further enhanced unit part load efficiency
- ✦ **Double Thick Insulation** – Evaporator with double thick 2” [50mm] closed cell insulation, for extra resistance to condensation
- ✦ **Modular Piping Kit** – Evaporator’s Interconnecting pipe and accessories for module chillers for convenient assembly at site.
- ✦ **Evaporator Anti-Freeze Protection** – When chiller is not operating at ambient temperature 32°F [0°C] or below, the immersion heater and circulating pump will be in operation to prevent water freezing in evaporator
- ✦ **Protective Grille for Condenser Coil** – To protect condenser coil from unauthorized access
- ✦ **Evaporator Flanged Water Connection** – Flanged water connection is available as option
- ✦ **250 PSIG Working Pressure Vessel** – Evaporator with 250 psig working pressure on water side
- ✦ **Compressor Acoustic Jacket** - Compressor acoustic jacket can be added to further reduce the sound level
- ✦ **Dual Mode Operation** – The unit with dual mode operation can deliver chilled fluid temperature down to 18°F [-7.8°C] during ice making mode. Units with Dual Mode Operation is used for Ice Thermal Storage System
- ✦ **Low Temp. Operation** – The unit with Low Temp. Operation can deliver chilled fluid temperature down to 18°F [-7.8°C] for process cooling application
- ✦ **ASME/ PED/ CRN Compliance** – Evaporator with ASME/ PED/ CRN approval is available
- ✦ **CE Compliance** – Unit with CE compliance is available on request
- ✦ **BMS Communication** – Various add-on communication cards provide BMS communication via common protocols: Modbus RTU RS485 / TCP/IP, LONworks FTT10, BACnet over IP / MSTP / PTP

# OPTIONS AND ACCESSORIES

## ELECTRICAL AND CONTROLS

- ✿ **Unit Mounted Main Disconnect Switch** – Non-fused disconnect switch with external lockable handle is furnished to isolate unit main incoming power supply for servicing
- ✿ **Single Power Connection Point** – Quick and easy field installation with one main power supply termination. (Applicable to Models AVX-B 470M only)
- ✿ **Ground Fault Interrupt (GFI)** – Provides equipment with ground fault protection
- ✿ **Ammeter/ Voltmeter** – Analog ammeter and voltmeter with 3 phase selector switch for indication, located inside the control panel
- ✿ **Chilled Water Reset/ Demand Limiting** – Low level interfacing with Building Automation System (BAS). Chilled Water Reset allows controlled temperature setpoint to be reset by a 4-20mA signal from BAS; while Demand Limiting will limit the maximum current drawn by the compressors by 4-20mA signal from BAS
- ✿ **System Voltage Measurement** – System voltage option is a safety features to protect system from high and low voltage due to unbalance power supply. The controller will trigger alarm high or low voltage and cut-off running system
- ✿ **IP55 Control Panel** – IP55 rated control panel can be supplied for harsh working environment

## Factory Supplied, Field Installed By Customer

- ✿ **Evaporator Water Flow Switch**– Flow switch to be installed at evaporator outlet piping as safety interlock to evaporator water flow status. Three options are available: Weather tight flow switch with CE mark; NEMA 1 and NEMA 4 rated flow switch
- ✿ **Rubber-In-Shear Isolators** – Designed for ease of installation. These one-piece molded rubber isolators are applicable for most installations
- ✿ **Spring Isolators** – These housed spring assemblies have a neoprene friction pad at the bottom to prevent the passage of noise, and a spring locking levering bolt at the top. Neoprene inserts prevent contact between the steel upper and lower housings. Suitable for more critical application as compared to rubber-in-shear isolator
- ✿ **DB-LAN Master Slave Sequencing Control (MSS)** – Pre-programmed at factory; field supplied and installed inter-connection wiring between chillers to provide communication bus among chillers' controllers to enable Master-Slave Sequencing Control
- ✿ **Chiller Plant Manager (CPM)** – Factory supplied control panel; field supplied and installed interconnection wiring and field devices; for complete chiller plantroom automation.

## DB DIRECTOR

### (For US Region Only)

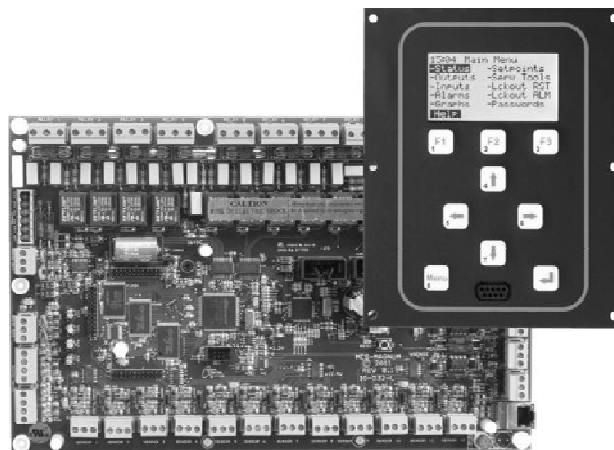

DB-Director control system is offered to US region as an option to Vision 2020i control system.

DB-Director is a rugged microprocessor based controller designed for the HVAC/R applications. DB-Director provides flexibility with setpoints and control options that can be selected prior to commissioning a system or when the unit is live and functioning. Displays, alarms and other interfaces are accomplished in a clear and simple language that informs the user as to the status of the controller.

DB-Director is equipped with 128 x 64 pixels monochrome graphics LCD display with 2.8" diagonal viewing area, and 9 dedicated keys that enable user to access information, base on security level of the password. The user terminal is allows displaying and easy access to the unit working conditions, compressor run times, alarm histories and modify the parameters. Multiple messages will be displayed by automatically scrolling from each message to the next. All of these messages are spelled out in English language on the display terminal.

The display also has an automatically self-test of the controller on system start-up. For more detail operation of the DB-Director keypad, please refer to the Unit operation Manual.

### Remote Monitoring For DB-Director

DB-Director is equipped with RS485 and Ethernet communication ports as standard. This user friendly design allows Building Management System (BMS) to interface directly with the chiller via either of Modbus RTU, Modbus IP, or BACnet IP communication protocol.

LONworks or BACnet MSTP communication protocol can be established with installation of external adapter.

# OPERATING BENEFITS

## EFFICIENCY AND RELIABILITY

### Energy Efficiency

- ✦ VFD driven compressor provides superior efficiency and sound level at part load
- ✦ Designed to provide the greatest amount of cooling for the least power input over the entire operating range of your building
- ✦ Delivers outstanding efficiency and total energy savings through the utilization of economizer cycle and advanced controller staging; to produce greater capacity with fewer compressors
- ✦ Maximized performance through optimized components matching and multiple compressors
- ✦ High efficiency oil recovery system guarantees removal of oil carried over in the refrigerant and maintains the heat exchangers at their maximum efficiency at both full and part load

### Refrigerant Compatibility

- ✦ Designed to operate with environmentally sound and economically smart HFC-134a with proven efficiency and reliability
- ✦ Consult Factory for use of other HFC refrigerants.

### Flooded Evaporator

- ✦ Flooded evaporator design that fully utilized and maximized the heat transfer area available in the evaporator; operates with lower suction superheat, smaller evaporator approach. These have greatly improved efficiency of chiller with flooded evaporator
- ✦ Flooded evaporator water heads can be removed easily without dismantling the chilled water piping connections, for inspection and for mechanical tubes cleaning with brushes or auto-brush. This will enable low tube fouling factor in the evaporator to be ensured, thus maintaining system efficiency

### Operational Advantages

- ✦ Dramatic payback in reduced maintenance and overhaul costs both in downtime and in labor expenditures
- ✦ Ease of troubleshooting through controller retention of monitored functions

### Factory Testing

- ✦ Each chiller undergoes the factory testing prior to unit shipment. This assures consistencies of workmanship at highest quality
- ✦ Thus, all units shipped are completely factory tested; charged and adjusted according to the design parameters, for ease of installation and minimal field start-up adjustments

## Control Flexibility

- ✦ Controller-based with DDC controller (direct digital control) features precise push button control over every aspect of operation with built-in standard features that maximized energy savings on start-up and throughout the life of your equipment
- ✦ Ensured uniform compressor loading and optimal energy efficiency through controller to controls which utilize pressure transducers to measure evaporator and condenser pressure
- ✦ Lower energy costs resulting from automatic load monitoring and increased accuracy and efficiency in compressor staging
- ✦ Various communication options for remote monitoring of the unit operation
- ✦ Proactive control anticipates problems and takes corrective action before they occur. Controls will unload compressor(s) if head or suction pressure approach limits. This will enable unit to stay on line while warning operator of potential problems
- ✦ Stable and efficient operation with precise chilled water temperature control. Chilled water temperature is controlled at  $\pm 0.8$  °F [0.5 °C] range for your comfort cooling, with best energy saving

## REFRIGERATION CYCLE

Dunham-Bush rotary screw air cooled chillers are designed for efficiency and reliability. The rotary screw compressor is a positive displacement, variable capacity compressor that will allow operation over a wide variety of conditions.

The refrigerant management system is shown in the refrigerant cycle diagram.

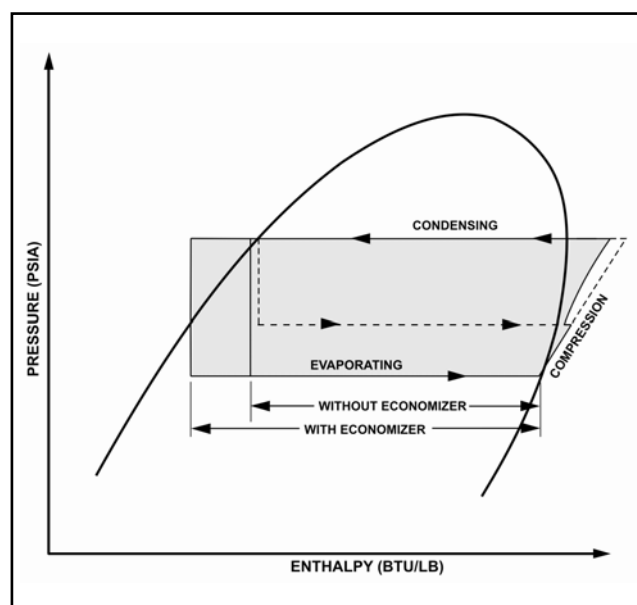



# OPERATING BENEFITS

---

Liquid refrigerant enters the flooded evaporator uniformly where it absorbs heat from water flowing through the evaporator tubes. The vaporized refrigerant is then drawn into the suction port of the compressor where the positive displacement compression begins.

This partially compressed gas is then combined with additional gas from the vapor injection port at an intermediate pressure. Compressed gaseous refrigerant is then discharged into the integral oil separator where oil, which is contained in the refrigerant vapor, is removed and returned to the compressor oil sump.

Fully compressed and superheated refrigerant is then discharged into the condenser, where air is being drawn through the condenser tube by the propeller fan cools and condenses the refrigerant. The liquid refrigerant then passes through the economizer. A portion of liquid refrigerant is tapped passes through the expansion valve back into the economizer for further subcooling of main liquid refrigerant flow.

The gaseous refrigerant is then drawn out of the economizer and into the vapor injection port of the compressor. The remaining subcooled liquid refrigerant then passes through electronic expansion valve which reduces refrigerant pressure to evaporator levels where it is then distributed evenly into the evaporator.

With the additional subcooling, the enthalpy of the refrigerant flowing into the evaporator is reduced which increases the refrigeration effect and improves the efficiency of the refrigeration cycle.

## **Economizer/ Vapor Injection Cycle for Increase Capacity and Higher EER**

The renowned Dunham-Bush screw compressor allows for economizer vapor injection cycle to be incorporated, increasing capacity by significantly with marginal increase in kW-input. Thus, unit EER is improved!

## **PART-LOAD PERFORMANCE**

Through the use of economizer, electronic expansion valve and multiple compressors, Dunham-Bush air cooled chillers have some of the best part-load performance characteristics in the industry when measured in accordance with AHRI Standard 550/590.

In most cases, actual building system loads are significantly less than full load design conditions, therefore chillers operate at part load most of the time.

Dunham-Bush air cooled chillers combine the efficient operation of multiple compressors with an economizer cycle and advanced controller to yield the best total energy efficiency and significant operating saving under any load.

When specifying air conditioning equipment, it is important to consider the system load characteristics for the building application. In a typical city, the air conditioning load will vary according to changes in the ambient temperature. Weather data compiled over many years will predict the number of hours that equipment will operate at various load percentages.

The Air Conditioning and Refrigeration Institute (AHRI) has established a system, in AHRI Standard 550/590, for measuring total chiller performance over full and part-load conditions. It defines the Integrated Part-Load Value (IPLV) as an excellent method of comparing diverse types of equipment on an equal basis. The IPLV is a single number estimate of a chiller's power use weighted for the number of hours the unit might spend at each part-load point. IPLV's are based on Standard Rating Conditions.

The formula for calculating an IPLV is:

$$\text{IPLV} = \frac{1}{\frac{0.01}{A} + \frac{0.42}{B} + \frac{0.45}{C} + \frac{0.12}{D}}$$

**where: A= kW/ton at 100% load point  
B= kW/ton at 75% load point  
C= kW/ton at 50% load point  
D= kW/ton at 25% load point**





# ELECTRICAL DATA

Model AVX-B	Compressor Data				Condenser Fan Motor Data**			Unit Data <sup>1</sup>			Unit Data <sup>2</sup>		
	Qty	RLA <sup>1</sup>	RLA <sup>2</sup>	LRA	Qty	HP	FLA	RLA	MCA	MFS	RLA	MCA	MFS
<b>Power Supply : 380Vac-3Ph-50Hz</b>													
115S	1	195	233	999	7	3	6.3	239	288	400	277	335	500
140S	1	236	310	999	7	3	6.3	280	339	500	354	432	700
170S	1	286	372	1295	9	3	6.3	343	414	700	429	522	800
200S	1	326	417	1391	11	3	6.3	395	477	800	486	591	1000
225S	1	373	461	1878	11	3	6.3	442	536	800	530	646	1000
225T	2	199	238	999	12	3	6.3	474	523	700	552	611	800
250T	1	184	217	999	14	3	6.3	499	556	700	573	640	800
	1	227	268	1295									
265S	1	435	540	2481	13	3	6.3	517	626	1000	622	757	1200
280T	2	232	300	999	14	3	6.3	552	610	800	688	763	1000
300S	1	497	615	2887	15	3	6.3	592	716	1200	710	863	1200
300T	1	235	275	1295	16	3	6.3	610	678	800	699	780	1000
	1	274	323	1391									
330T	2	287	381	1295	16	3	6.3	675	747	1000	863	958	1200
350T	1	281	330	1391	18	3	6.3	719	801	1000	826	922	1200
	1	325	383	1878									
380T	1	340	434	1391	18	3	6.3	741	826	1000	924	1033	1200
	1	288	377	1295									
400T	2	352	450	1391	18	3	6.3	817	905	1200	1013	1126	1200
470M <sup>†</sup>	1	386	479	1878	11	3	6.3	455	552	800	548	668	1000
	1	373	479	1878									
470M <sup>††</sup>	2	386	479	1878	22	3	6.3	911	1007	1200	1096	1216	1600
<b>Power Supply : 400-415Vac-3Ph-50Hz</b>													
115S	1	185	221	949	7	3	6	227	273	450	263	319	500
140S	1	224	295	949	7	3	6	266	322	500	337	410	700
170S	1	272	353	1230	9	3	6	326	394	600	407	496	800
200S	1	310	396	1321	11	3	6	376	454	700	462	561	900
225S	1	354	438	1784	11	3	6	420	509	800	504	613	1000
225T	2	189	226	949	12	3	6	450	497	700	524	581	800
250T	1	175	206	949	14	3	6	475	529	700	545	609	800
	1	216	255	1230									
265S	1	413	513	2357	13	3	6	491	594	1000	591	719	1200
280T	2	220	285	949	14	3	6	524	579	800	654	725	1000
300S	1	472	584	2743	15	3	6	562	680	1000	674	820	1200
300T	1	223	261	1230	16	3	6	579	644	800	664	741	1000
	1	260	307	1321									
330T	2	273	362	1230	16	3	6	642	710	1000	820	910	1200
350T	1	267	314	1321	18	3	6	684	761	1000	786	877	1200
	1	309	364	1784									
380T	1	323	412	1321	18	3	6	705	786	1000	878	982	1200
	1	274	358	1230									
400T	2	334	428	1321	18	3	6	776	860	1200	963	1070	1200
470M	1	367	455	1784	11	3	6	433	525	800	521	635	1000
	1	354	455	1784									
470M*	2	367	455	1784	22	3	6	866	958	1200	1042	1156	1600
<b>Power Supply : 460Vac-3Ph-60Hz</b>													
115S	1	161	193	999	7	3	4.4	192	232	400	224	272	450
140S	1	195	257	999	7	3	4.4	226	275	450	288	352	600
170S	1	237	307	1295	9	3	4.4	277	336	500	347	423	700
200S	1	270	345	1391	11	3	4.4	318	386	600	393	480	800
225S	1	308	381	1878	11	3	4.4	356	433	700	429	525	800
225T	2	164	197	999	12	3	4.4	381	422	600	447	496	600
250T	1	152	179	999	14	3	4.4	402	449	600	463	518	700
	1	188	222	1295									
265S	1	359	446	2481	13	3	4.4	416	506	800	503	615	1000
280T	2	191	248	999	14	3	4.4	444	491	700	558	620	800
300S	1	410	508	2887	15	3	4.4	476	579	1000	574	701	1200
300T	1	194	227	1295	16	3	4.4	490	547	700	564	631	800
	1	226	267	1391									
330T	2	237	315	1295	16	3	4.4	544	604	800	700	779	1000
350T	1	232	273	1391	18	3	4.4	579	646	800	668	747	1000
	1	268	316	1878									
380T	1	281	359	1391	18	3	4.4	598	668	800	749	839	1000
	1	238	311	1295									
400T	2	290	376	1391	18	3	4.4	659	732	1000	831	925	1200
470M <sup>†</sup>	1	319	396	1878	11	3	4.4	367	447	700	444	543	800
	1	308	396	1878									
470M <sup>††</sup>	2	319	396	1878	22	3	4.4	735	815	1000	888	988	1200

\* Modular unit with single power entry.

\*\* Fixed Speed Condenser Fan Motor

† Consult factory for Model AVX-B 470M with power supply 380V/3P/50Hz or 380V/3P/60Hz

† Rating Conditions: Evaporator leaving fluid temperature 44°F [6.7°C] with fluid flow rate 2.4 Usgpm/ton; ambient temperature at 95°F [35°C]; evaporator fouling factor 0.0001hr.ft<sup>2</sup>.°F/Btu

‡ Rating Conditions: Evaporator leaving fluid temperature 44°F [6.7°C] with fluid flow rate 2.4 Usgpm/ton; ambient temperature at 115°F [46°C]; evaporator fouling factor 0.0001hr.ft<sup>2</sup>.°F/Btu

Note: RLA – Running Load Amps

MCA – Minimum Circuit Ampacity

MFS – Maximum Fuse Size

LRA – Lock Rotor Amp

# SOUND PRESSURE DATA

## 50Hz

Model AVX-B	Octave Band (Hz)								Total dB (A)
	63	125	250	500	1K	2K	4K	8K	
115S	45	53	57	58	63	53	44	38	66
140S	45	53	57	58	63	53	44	38	66
170S	46	54	58	59	63	54	46	39	66
200S	47	55	59	59	63	54	45	39	66
225S	47	55	58	60	62	55	46	39	66
225T	47	55	59	60	66	55	46	40	68
250T	47	55	60	60	65	56	47	41	68
265S	47	55	59	60	62	53	45	39	66
280T	48	55	60	61	66	55	46	40	68
300S	48	56	59	60	62	53	45	39	66
300T	48	56	60	61	65	57	48	41	68
330T	48	56	60	61	65	57	48	41	68
350T	48	56	60	61	65	57	48	41	68
380T	48	56	61	61	65	57	48	42	68
400T	48	56	61	61	65	56	47	41	68
470M	49	57	61	62	64	57	48	42	68

Notes: 1) Unit Sound Pressure Level (Lp) @ 33 ft [10m] (free field), ± 2dB(A) tolerance.  
 2) Further unit noise reduction 2dB(A) with compressor acoustic jacket (option).

## 60Hz

Model AVX-B	Octave Band (Hz)								Total dB (A)
	63	125	250	500	1K	2K	4K	8K	
115S	57	53	56	57	63	52	43	37	66
140S	57	53	56	57	63	52	43	37	66
170S	58	54	57	57	62	54	45	38	66
200S	58	55	57	58	62	53	45	38	66
225S	58	55	57	58	62	54	45	39	66
225T	59	55	58	59	65	54	46	39	68
250T	59	56	58	59	65	56	47	40	68
265S	59	55	57	59	62	52	44	38	66
280T	59	56	58	59	65	54	46	39	68
300S	59	56	57	59	62	52	44	38	66
300T	60	56	59	59	65	56	47	40	68
330T	60	56	59	59	65	56	47	41	68
350T	60	56	59	60	64	56	47	41	68
380T	60	56	59	59	65	57	48	41	68
400T	60	56	59	59	65	55	47	40	68
470M	61	57	59	61	64	56	48	41	68

Notes: 1) Unit Sound Pressure Level (Lp) @ 33 ft [10m] (free field), ± 2dB(A) tolerance.  
 2) Further unit noise reduction 2dB(A) with compressor acoustic jacket (option).

# DIMENSIONAL DATA

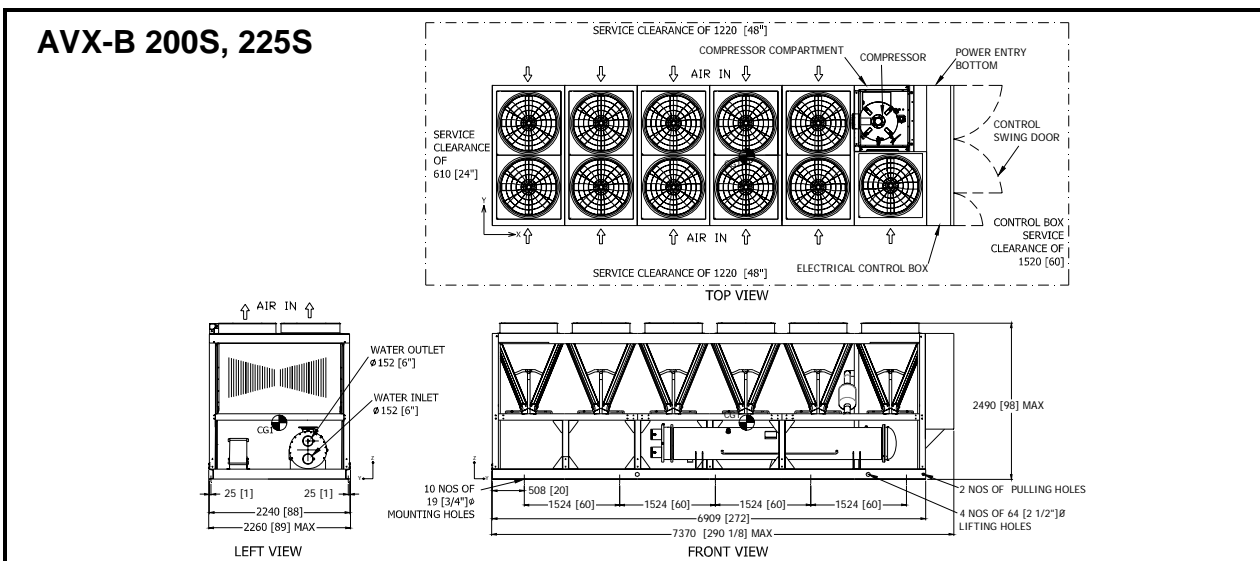
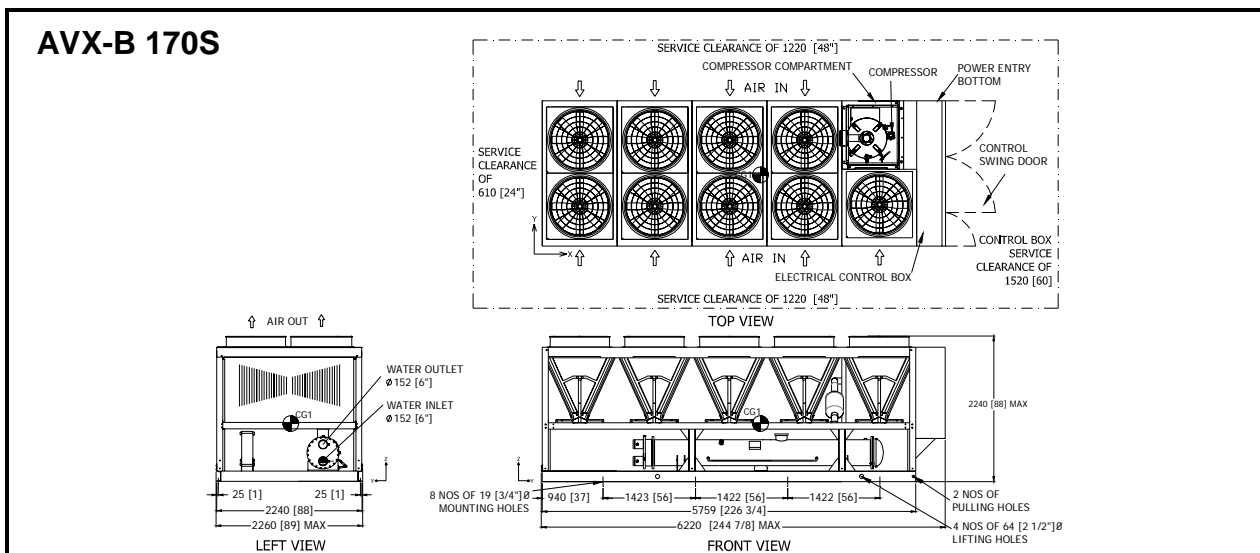
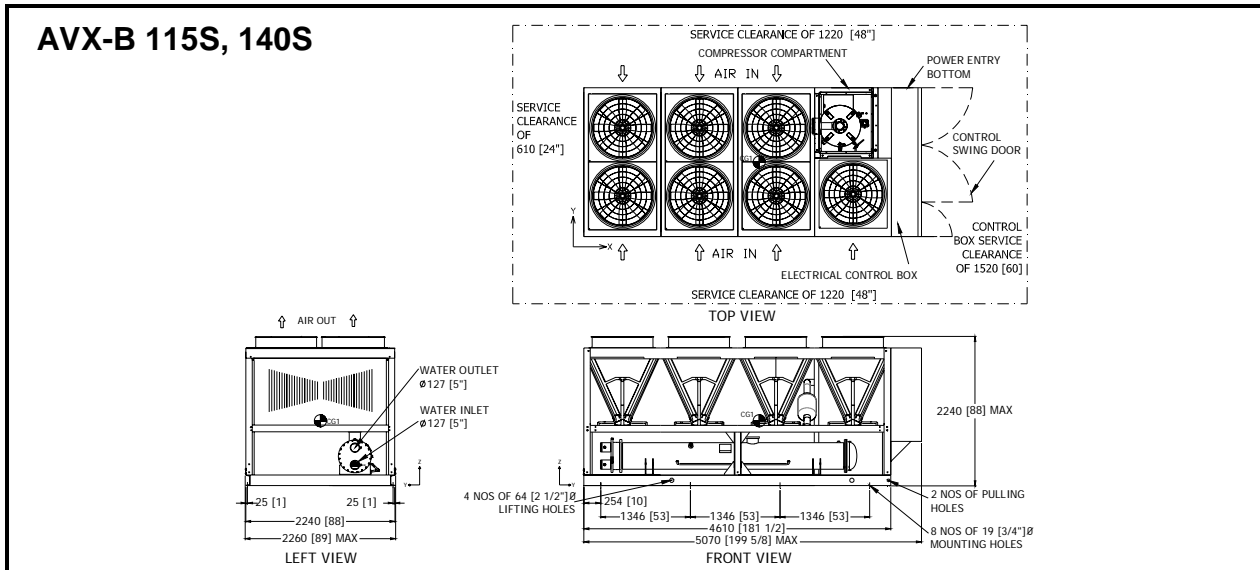

Notes: 1. All dimensions are in millimeters[inches].  
 2. Please consult factory for the details of the unit with UL certified VFD.

# DIMENSIONAL DATA

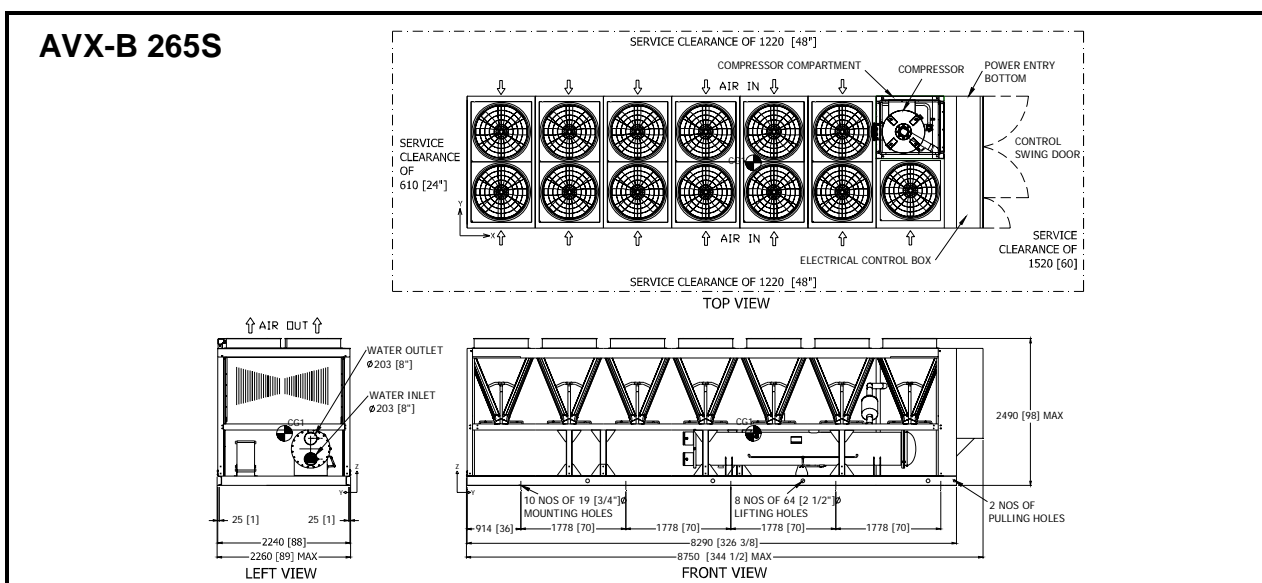
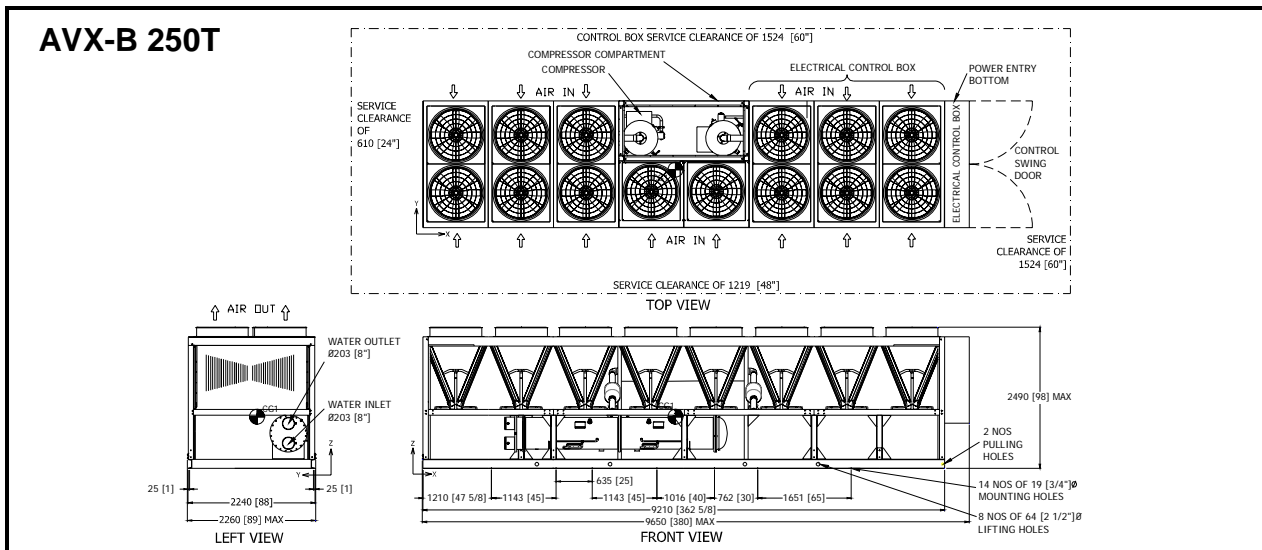
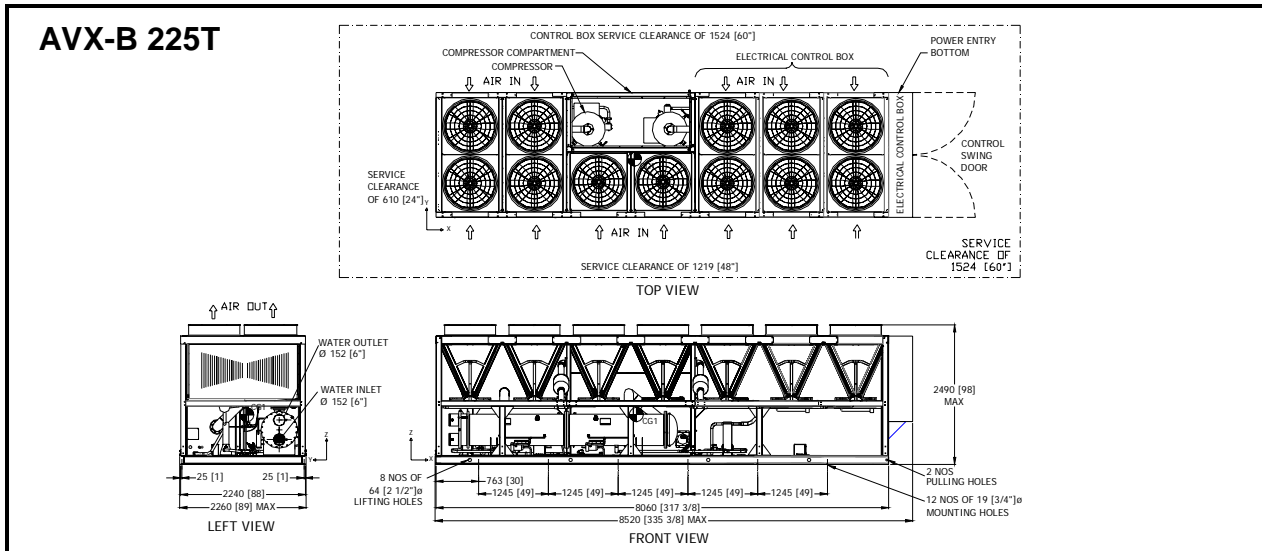

Notes: 1. All dimensions are in millimeters[inches].  
 2. Please consult factory for the details of the unit with UL certified VFD.

# DIMENSIONAL DATA

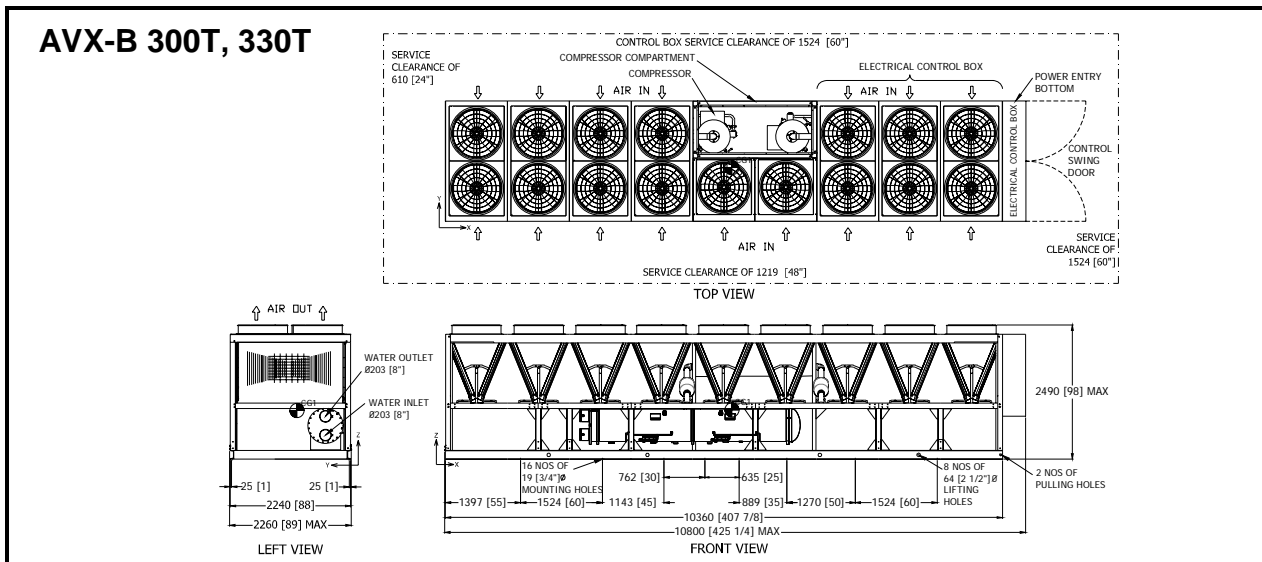
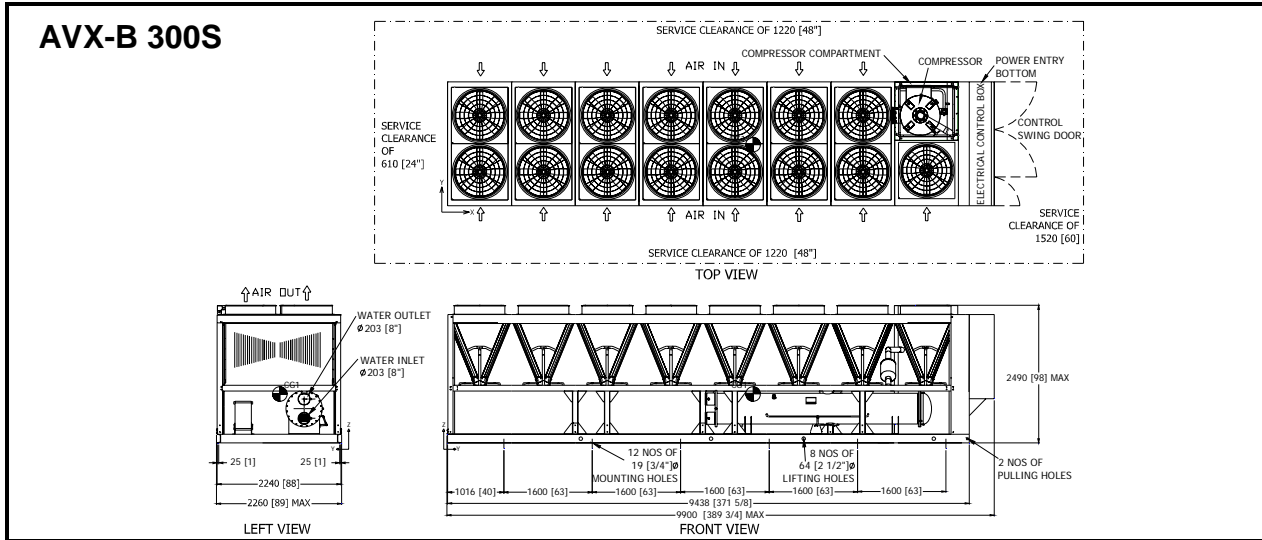
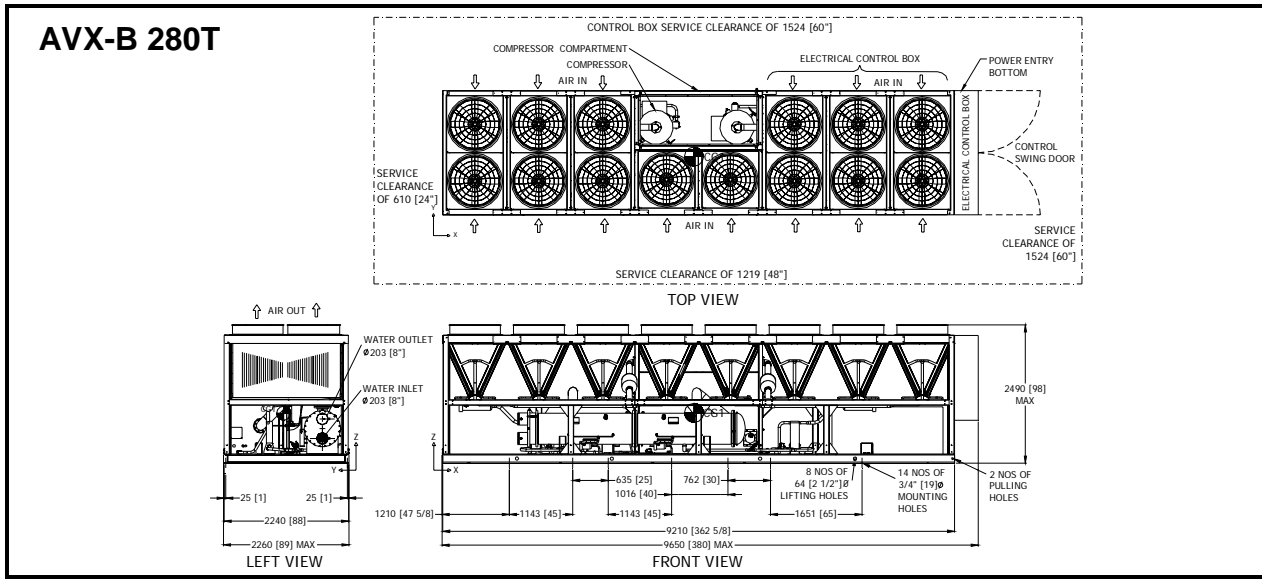

Notes: 1. All dimensions are in millimeters[inches].  
2. Please consult factory for the details of the unit with UL certified VFD.

# DIMENSIONAL DATA

## AVX-B 350T, 380T, 400T

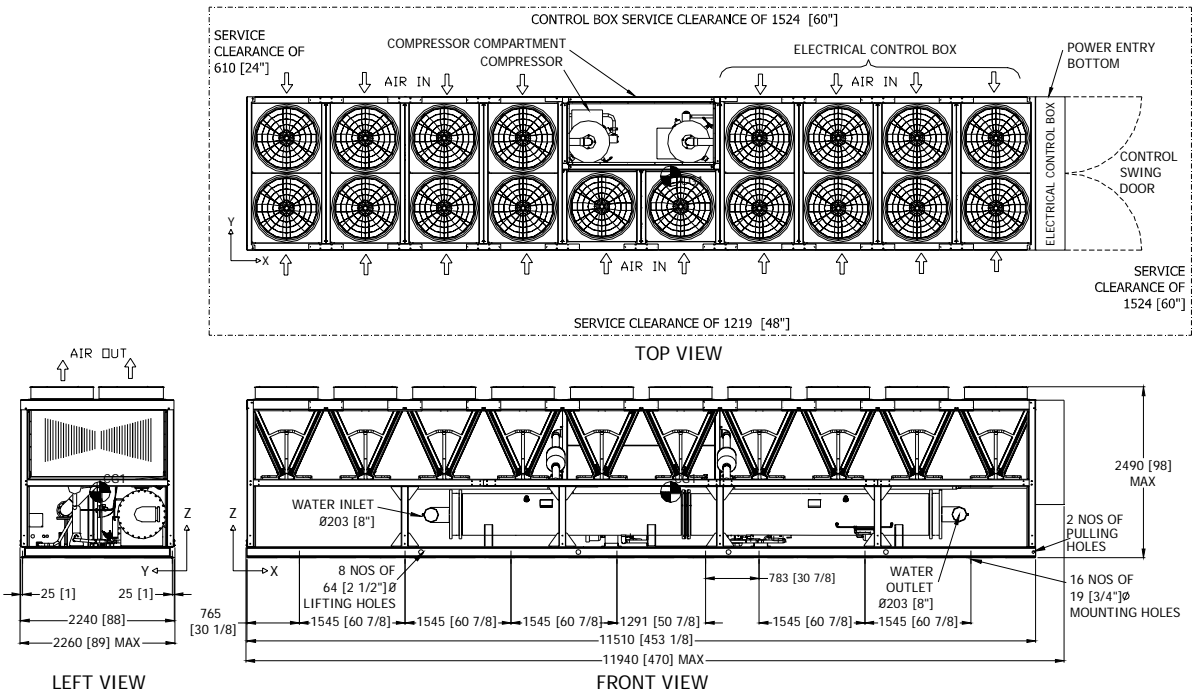

## AVX-B 470M

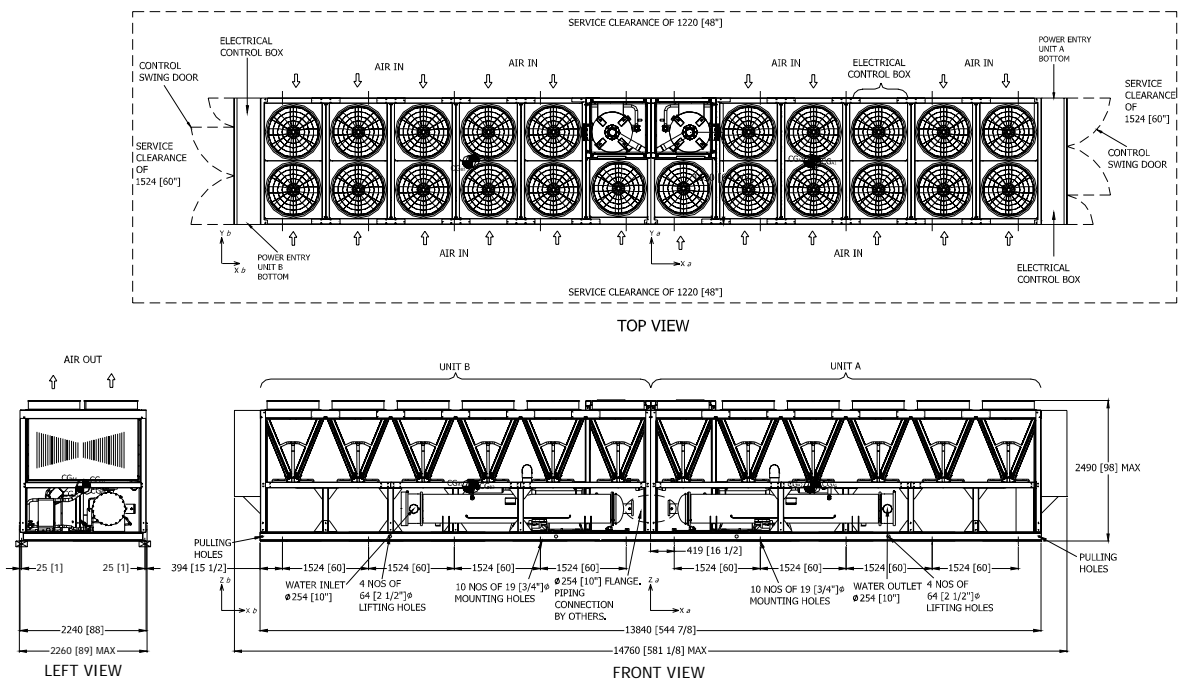

Notes: 1. All dimensions are in millimeters[inches].  
2. Please consult factory for the details of the unit with UL certified VFD.



# FLOOR LOADING DIAGRAM

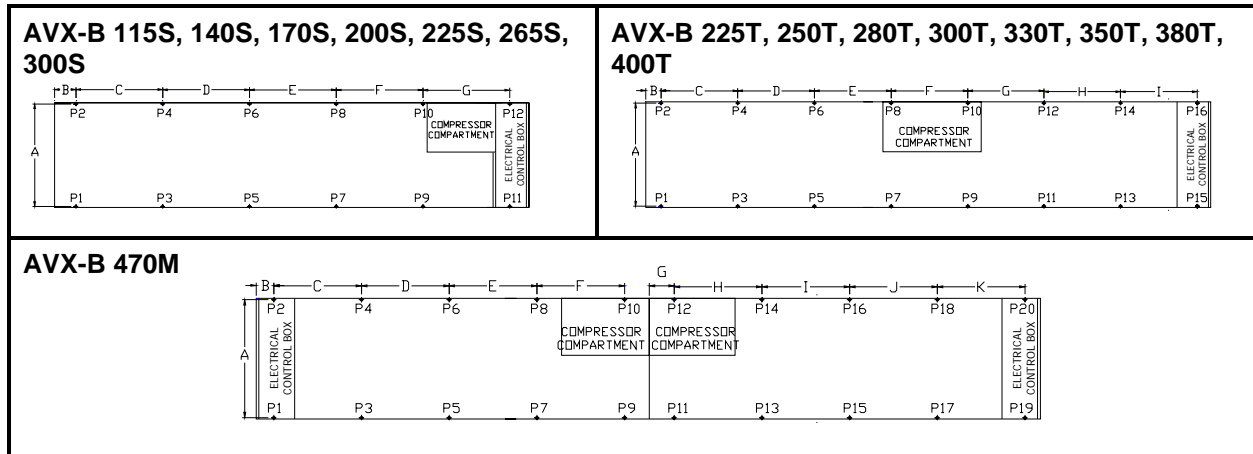

## a.) Point Load Location – inches [mm]

Model AVX-B	Dimensions - Inches [mm]										
	A Dim.	B Dim.	C Dim.	D Dim.	E Dim.	F Dim.	G Dim.	H Dim.	I Dim.	J Dim.	K Dim.
115S	86 [2184]	10 [254]	53 [1346]	53 [1346]	53 [1346]	-	-	-	-	-	-
140S	86 [2184]	10 [254]	53 [1346]	53 [1346]	53 [1346]	-	-	-	-	-	-
170S	86 [2184]	37 [940]	56 [1423]	56 [1423]	56 [1423]	-	-	-	-	-	-
200S	86 [2184]	20 [508]	60 [1524]	60 [1524]	60 [1524]	60 [1524]	-	-	-	-	-
225S	86 [2184]	20 [508]	60 [1524]	60 [1524]	60 [1524]	60 [1524]	-	-	-	-	-
265S	86 [2184]	36 [914]	70 [1778]	70 [1778]	70 [1778]	70 [1778]	-	-	-	-	-
300S	86 [2184]	40 [1016]	63 [1600]	63 [1600]	63 [1600]	63 [1600]	63 [1600]	-	-	-	-
225T	86 [2184]	30 [763]	49 [1245]	49 [1245]	49 [1245]	49 [1245]	49 [1245]	-	-	-	-
250T	86 [2184]	47 5/8 [1210]	45 [1143]	25 [635]	45 [1143]	40 [1016]	30 [762]	65 [1651]	-	-	-
280T	86 [2184]	47 5/8 [1210]	45 [1143]	25 [635]	45 [1143]	40 [1016]	30 [762]	65 [1651]	-	-	-
300T	86 [2184]	55 [1397]	60 [1524]	45 [1143]	30 [762]	25 [635]	35 [889]	50 [1270]	60 [1524]	-	-
330T	86 [2184]	55 [1397]	60 [1524]	45 [1143]	30 [762]	25 [635]	35 [889]	50 [1270]	60 [1524]	-	-
350T	86 [2184]	30 1/8 [765]	60 7/8 [1545]	60 7/8 [1545]	60 7/8 [1545]	50 7/8 [1291]	30 7/8 [783]	60 7/8 [1545]	60 7/8 [1545]	-	-
380T	86 [2184]	30 1/8 [765]	60 7/8 [1545]	60 7/8 [1545]	60 7/8 [1545]	50 7/8 [1291]	30 7/8 [783]	60 7/8 [1545]	60 7/8 [1545]	-	-
400T	86 [2184]	30 1/8 [765]	60 7/8 [1545]	60 7/8 [1545]	60 7/8 [1545]	50 7/8 [1291]	30 7/8 [783]	60 7/8 [1545]	60 7/8 [1545]	-	-
470M	86 [2184]	16 1/2 [419]	60 [1524]	60 [1524]	60 [1524]	60 [1524]	16 1/2 [419]	60 [1524]	60 [1524]	60 [1524]	60 [1524]

## b.) Point Load Data – lbs [kg]

Model AVX-B	Point Load																				Operating Weight
	P1	P2	P3	P4	P5	P6	P7	P8	P9	P10	P11	P12	P13	P14	P15	P16	P17	P18	P19	P20	
115S	1065	754	1026	891	1258	1229	1065	1415	-	-	-	-	-	-	-	-	-	-	-	-	8702
483	342	465	404	571	557	483	642	-	-	-	-	-	-	-	-	-	-	-	-	-	3947
140S	1051	750	1062	922	1269	1233	1151	1447	-	-	-	-	-	-	-	-	-	-	-	-	8886
477	340	482	418	576	559	522	656	-	-	-	-	-	-	-	-	-	-	-	-	-	4031
170S	1371	998	1258	970	1326	1102	1523	2025	-	-	-	-	-	-	-	-	-	-	-	-	10573
622	453	571	440	601	500	691	919	-	-	-	-	-	-	-	-	-	-	-	-	-	4796
1184	947	1218	970	1224	1024	1491	1394	1353	1776	-	-	-	-	-	-	-	-	-	-	-	12581
537	430	553	440	555	465	676	632	614	805	-	-	-	-	-	-	-	-	-	-	-	5707
225S	1255	980	1293	1008	1281	1061	1543	1451	1406	1886	-	-	-	-	-	-	-	-	-	-	13163
569	445	587	457	581	481	700	658	638	855	-	-	-	-	-	-	-	-	-	-	-	5971
225T	2047	1195	1544	1345	2123	1672	1564	1637	1032	1040	985	957	-	-	-	-	-	-	-	-	17141
929	542	701	610	963	759	709	743	468	472	447	434	-	-	-	-	-	-	-	-	-	7775
250T	988	774	2025	1046	1361	1100	1693	1516	2136	1869	1147	1124	1095	1055	-	-	-	-	-	-	18930
448	351	919	475	617	499	768	688	969	848	520	510	496	479	-	-	-	-	-	-	-	8587
265S	1515	1174	1606	1302	1611	1350	1955	1938	1472	2025	-	-	-	-	-	-	-	-	-	-	15948
687	533	729	591	731	612	887	879	668	919	-	-	-	-	-	-	-	-	-	-	-	7234
280T	994	776	2065	1072	1370	1103	1696	1515	2128	1842	1148	1123	1098	1061	-	-	-	-	-	-	18993
451	352	937	486	621	500	769	687	965	836	521	509	498	481	-	-	-	-	-	-	-	8616
300S	1342	1032	1390	1093	1462	1171	1469	1190	1804	1968	1470	2015	-	-	-	-	-	-	-	-	17408
609	468	631	496	663	531	667	540	818	893	667	914	-	-	-	-	-	-	-	-	-	7896
993	777	2085	1148	1688	1126	1581	1526	1834	1193	2247	1949	1139	1093	966	861	-	-	-	-	-	22207
450	352	946	521	766	511	717	692	832	541	1019	884	517	496	438	391	-	-	-	-	-	10073
330T	996	779	2097	1173	1690	1120	1557	1458	1832	1177	2253	1952	1159	1124	992	887	-	-	-	-	22246
452	353	951	532	766	508	706	661	831	534	1022	885	526	510	450	402	-	-	-	-	-	10091
350T	911	842	1043	894	1745	1324	1835	1786	1773	1787	1698	1561	1294	1059	1145	1009	-	-	-	-	21708
413	382	473	405	792	601	832	810	804	811	770	708	587	480	520	458	-	-	-	-	-	9847
380T	910	835	1044	890	1739	1295	1803	1693	1751	1697	1716	1562	1310	1050	1152	1003	-	-	-	-	21449
413	379	474	404	789	588	818	768	794	770	779	709	594	476	522	455	-	-	-	-	-	9729
400T	912	841	1049	904	1744	1309	1811	1714	1784	1777	1732	1604	1313	1059	1154	1008	-	-	-	-	21716
414	381	476	410	791	594	822	777	809	806	786	728	596	480	523	457	-	-	-	-	-	9850
470M	1048	1015	963	896	1607	1163	1469	1270	1716	2128	1603	2066	1535	1299	1663	1198	1003	939	1000	969	26550
476	460	437	406	729	528	666	576	778	965	727	937	696	589	754	544	455	426	453	439	12044	

Note: Please consult factory for the details of the unit with UL certified VFD.

# FIELD POWER & CONTROL WIRING SCHEMATIC

## TYPICAL FIELD WIRING DIAGRAM

### 1 Compressor

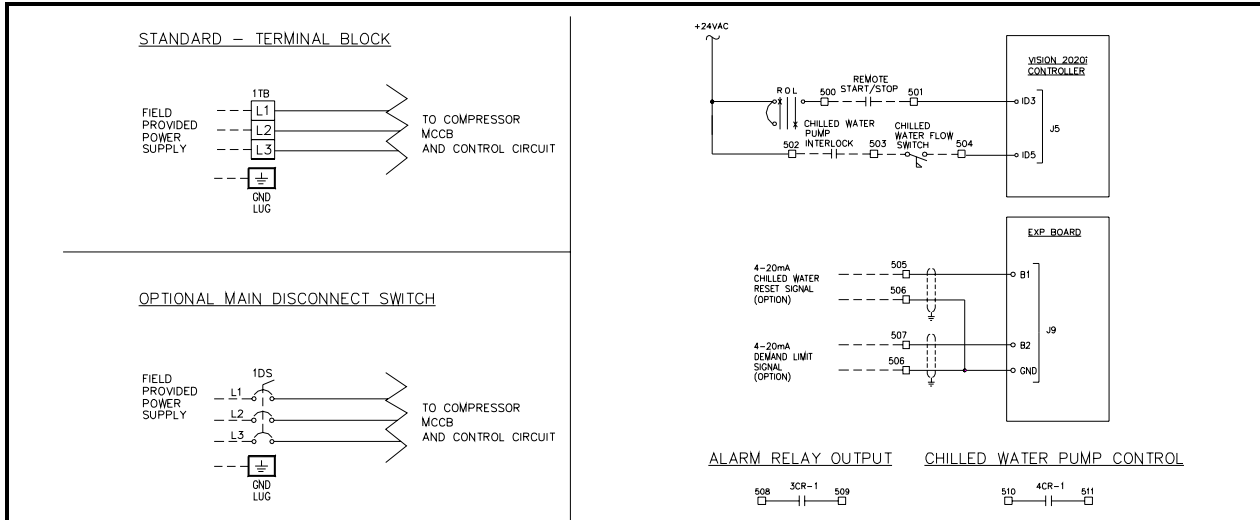

### 2 Compressors

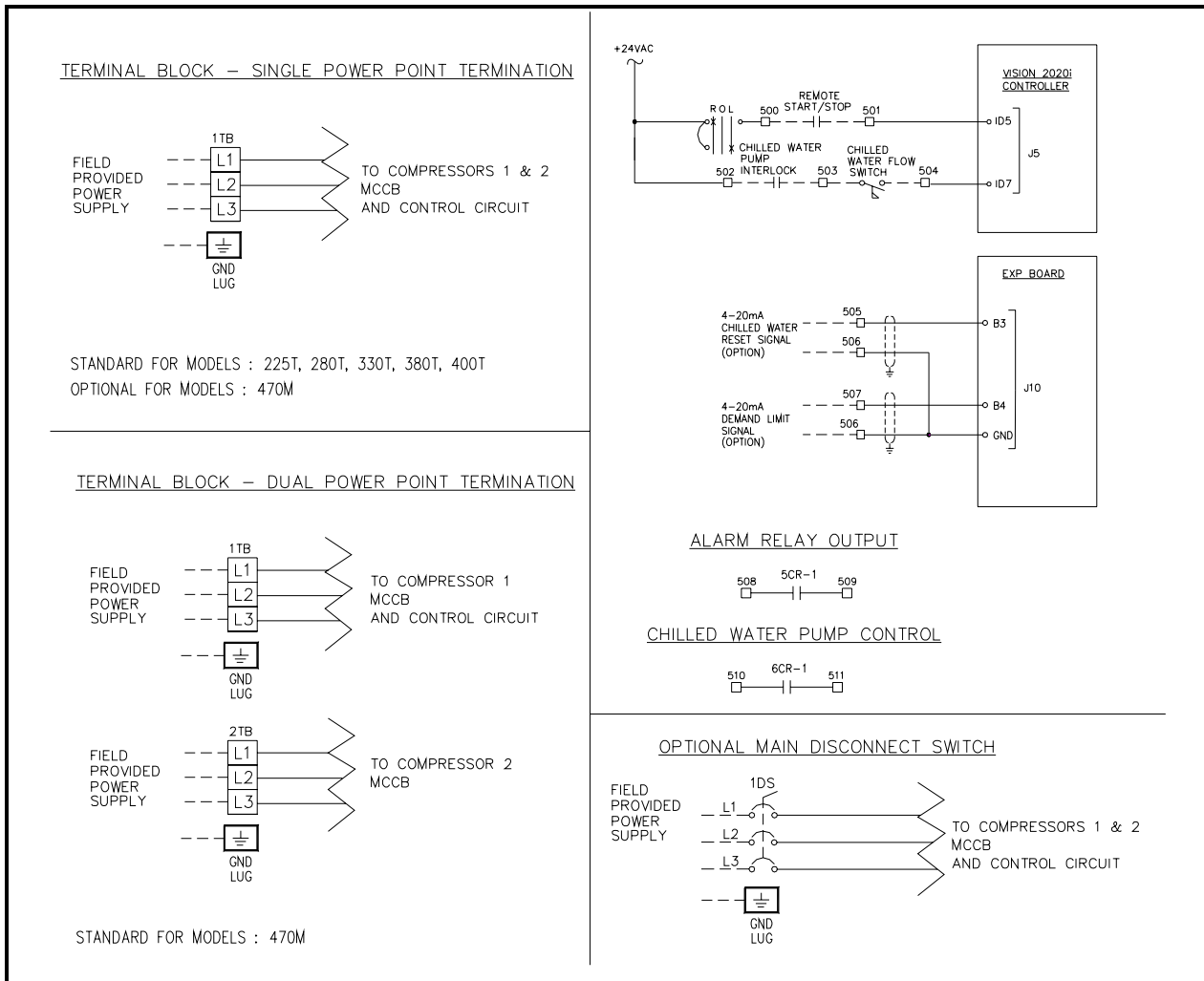

# APPLICATION DATA

## UNIT DESIGNED OPERATING RANGE

### Unit Operating Range – Ambient Temperature

The units are designed to operate at ambient temperature, 45~125°F [7~52°C], for high ambient series. If the unit requires to be operated at lower ambient temperature, the optional **Low Ambient Operation (LA1)**, or **Extra Low Ambient Operation (LA2)** shall be incorporated for stable operation.

### Operating Limits – Ambient Temperature

Operating Ambient Temperature	Minimum	Maximum
Standard Ambient Series With LA1 *With LA2	45°F [7°C]	115°F [46°C]
	14°F [-10°C]	
	-20°F [-29°C]	
High Ambient Series With LA1 *With LA2	45°F [7°C]	125°F [52°C]
	14°F [-10°C]	
	-20°F [-29°C]	

\* Please consult factory for LA2 option.

If wind velocity in the area is over 5 mph [8 kmph], wind barrier is recommended.

### Unit Operating Range – Evaporator Temperature

The unit is designed to deliver chilled fluid temperature within 40~50°F [4.5~10°C]. The unit can start and pull down with up to 80°F [27°C] entering-fluid temperature. For sustained operation, it is recommended that the entering fluid temperature not exceed 70°F [21°C].

For unit installation with minimum ambient temperature at 32°F [0°C] or below, **Evaporator Anti-Freeze Protection** option is recommended to prevent freezing of water in evaporator when the chiller is not in operation.

### Operating Limits – Leaving Fluid Temperature

Leaving Fluid Temperature	Minimum	Maximum
Standard	40 °F [4.5 °C]	50 °F [10 °C]
Dual Mode / Low Temp. Operation	18 °F [-7.8 °C]	50 °F [10 °C]

## EVAPORATOR FLUID CIRCUIT

### Wide Range ΔT - Low Flow Applications

Multiple smaller chillers may be applied in series, each providing a portion of the design temperature range typical 10°F [5.5°C] each.

Chilled fluid may be recirculated through the evaporator as shown below to allow the chiller to operate with acceptable flow rates and temperature ranges (Figure 1A).

Figure 1A

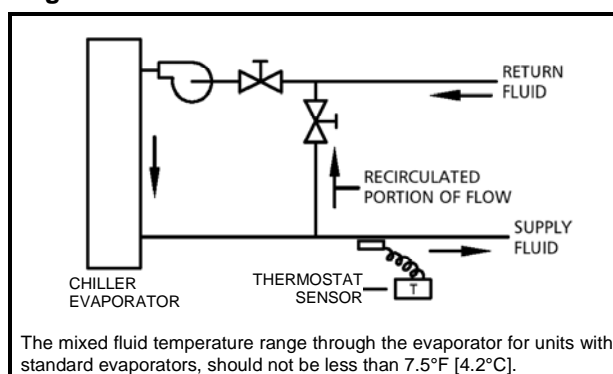

### Narrow Range ΔT - High Flow Applications

For Narrow Range ΔT applications, a partial evaporator bypass piping and valve configuration can be used as shown below.

This permits a higher ΔT and lower ΔP (pressure drop) through the evaporator (Figure 1B).

Figure 1B

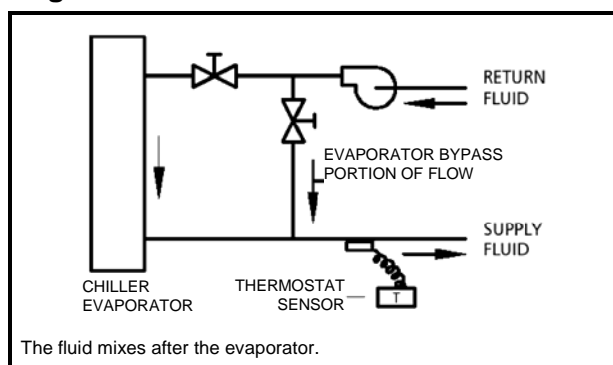

### Minimum Chilled Fluid Loop Volume

The evaporator fluid circuit requires a minimum system fluid volume of 3 US gallons per Ton [3.3 liters/ cooling kW] for stable operation. The minimum system fluid volume may increase up to 10 US gallons per Ton [11 liters/ cooling kW] for process cooling, low load applications with small temperature range and/or vastly fluctuating load conditions.

### Tanks for System Volume Enhancement

It may be necessary to install a tank in the system to provide sufficient system fluid volume, as shown below. The tank should be baffled and piped for proper fluid mixing to prevent stratification.

Figure 2A

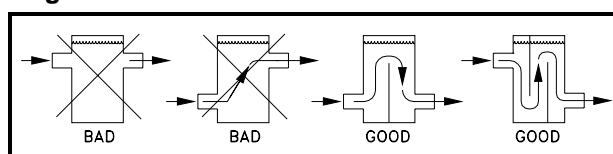

# APPLICATION DATA

**Figure 2B Single Loop System with Storage Tank to Increase Loop Volume**

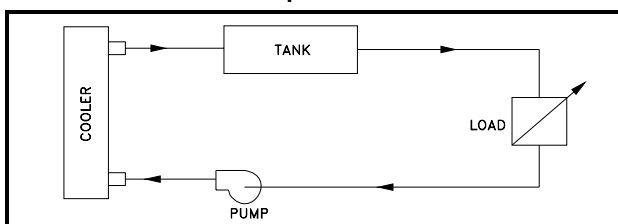

**Figure 2C Primary and Secondary Loop Systems are normally used where the secondary system has variable flow and/or multiple loads. See example below.**

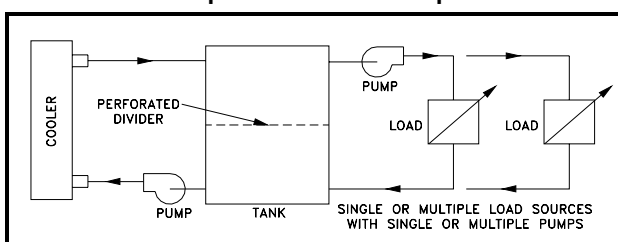

## Multiple Chillers In A Chilled Water System

Where the load is greater than available from one Achelous AVX-B, where standby capacity is required or the load profile dictates, multiple chillers may be piped in parallel. Units of equal size help to ensure fluid flow balance, but balancing valves ensure balanced flows even with dissimilar sized chillers.

Temperature controller sensors may or may not need to be moved to the common fluid piping depending on the specific application.

**Parallel Chiller Applications** – Both units operate simultaneously modulating with load variations. Each unit operates independently sensing its own leaving fluid temperature. The set point of each thermostat is set to maintain the desired loading scheme. (Figure 3A)

**Figure 3A**

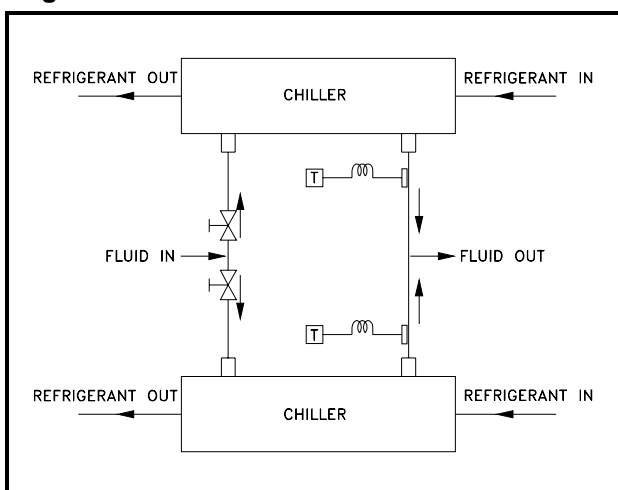

**Series Chiller Applications** – Where a large temperature range is required (over 25 °F [13.9 °C]), the chiller may be piped in series. In this case the units are controlled independently. The load is progressive by temperature so the chiller selections are critical. (Figure 3B)

**Figure 3B**

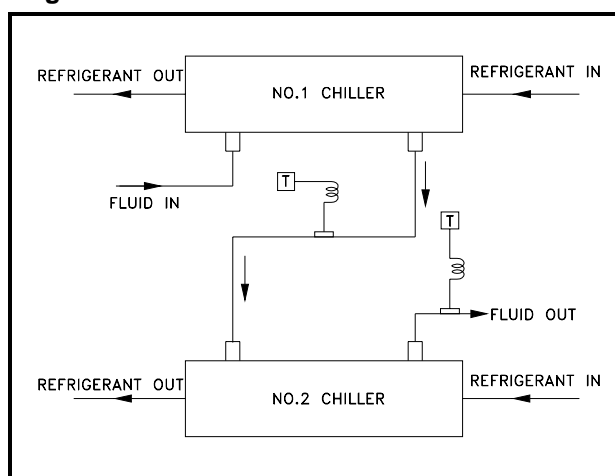

## Variable Evaporator Flow

Dunham-Bush chillers are capable for variable evaporator flow system. The chiller may operate to maintain constant leaving fluid temperature with evaporator flow rate changes, with below conditions fulfilled.

- ⊗ Evaporator fluid flow rate is within minimum and maximum flow rate of the unit at all time during the operation
- ⊗ Rate of flow changed shall not exceeded 10% per minute

Failure to comply with the above conditions will cause problem to the chiller operation and may cause the chiller to shutdown.

## Sound and Vibration

The compressors in AVX-B units are resiliently, mounted to reduce the transmission of any noise and vibration to the frame.

The compressors are not mounted on springs because extra movement may cause line breakage and refrigerant leaks. Unit isolation helps prevent any remaining sound or vibration from entering the building structure, piping or electrical service.

## Glycol Freeze Protection

If the chiller or fluid piping may be exposed to temperatures below freezing, glycol protection is recommended if the water is not drained. The recommended protection is 10°F [5.6°C] below the minimum ambient temperature in the equipment room and around piping. Use only glycol solutions approved for heat exchanger duty. DO NOT use automotive anti-freezing.

# APPLICATION DATA

If the equipment is being used to supply chilled fluid 38°F [3.3°C] or below, glycol should be used to prevent freeze damage. The freeze protection level should be 15°F [8.3°C] lower than the leaving brine temperature. The use of glycol causes a performance derate as shown below which needs to be included in the unit selection procedure.

**Table 1 : Ethylene Glycol**

% E. G. By Weight	Freeze Point		C1 Capacity Factor	K1 kW Rate	G1 Flow Factor	P1 P.D. Factor
	°F	°C				
10	26.2	-3.2	0.995	0.998	1.019	1.050
15	22.4	-5.3	0.991	0.997	1.030	1.083
20	17.8	-7.9	0.988	0.996	1.044	1.121
25	12.6	-10.8	0.984	0.995	1.060	1.170
30	6.7	-14.1	0.981	0.994	1.077	1.219
35	0.0	-17.8	0.977	0.992	1.097	1.275
40	-10.0	-23.3	0.973	0.991	1.116	1.331
45	-17.5	-27.5	0.968	0.990	1.138	1.398
50	-28.9	-33.8	0.964	0.989	1.161	1.466

**Table 2 : Propylene Glycol**

% P. G. By Weight	Freeze Point		C2 Capacity Factor	K2 kW Rate	G2 Flow Factor	P2 P.D. Factor
	°F	°C				
10	26.1	-3.3	0.988	0.994	1.005	1.019
15	22.8	-5.1	0.984	0.992	1.008	1.031
20	19.1	-7.2	0.978	0.990	1.010	1.051
25	14.5	-9.7	0.970	0.988	1.015	1.081
30	8.9	-12.8	0.962	0.986	1.021	1.120

**Table 3 : Correction Factor - Elevation**

Elevation above Sea Level		Capacity Correction Factor	kW Correction Factor
Feet [m]	Meters Factor		
0	0	1.00	1.00
2000	600	0.99	1.01
4000	1200	0.98	1.02
6000	1800	0.97	1.03

**Table 4 : Correction Factor - FF**

Fouling Factor		Capacity Correction Factor	kW Correction Factor
Hr.ft².°F/BTU	m².°C/kW		
0.0001	0.018	1.000	1.000
0.00025	0.044	0.993	0.997
0.00050	0.088	0.978	0.990
0.00100	0.176	0.951	0.978

Note: P.D. – Pressure drop across evaporator

## ICE THERMAL STORAGE SYSTEM (ITES)

The globe is progressively marching towards a serious electric energy crisis. The HVAC/R industry is shifting to operate with more efficient machines, as well as alternate system designs and solutions. Dunham-Bush, as a leader of HVAC/R solutions provider, we provide packaged solution for ITES, which include, equipments selections, chillers, Ice Cels and CPM for ITES system controls.

Dunham-Bush Chillers, with positive displacement rotary screw compressor can easily cool low temperature glycol down to 20°F [-6.7 °C] to charge the ice storage tanks. The same chiller can also produce warmer supply fluid temperature, 40 to 45 °F [4.4 to 7.2 °C], for those building systems designed for only peak shaving.

Dunham-Bush is the only HVAC/R manufacturer who can provide complete ITES packaged solution, with own products for chillers, ice storage tanks and plant room control system, with following benefits.

**Demand Charge:** ITES allows some of the peak demand to be shifted to low-demand nighttime periods, thus reducing demand charges for the entire year.

**Energy Cost:** ITES, by operating chillers at night, will fully utilize incentive on electricity night tariff, which is much lower compare to day tariff

**Rebates:** ITES usually qualifies for rebates offered by electric utilities or governments for equipment that shift peak loads to off-peak hours

**Colder Air Temperature:** ITES can produce chilled liquid at supply temperature of 38°F [3.3°C] or even lower without scarifying system's efficiencies. This realizes energy saving on chilled water pumping system, AHUs and FCUs. Colder supply air distribution lowers room humidity, and thus, comfort cooling can be achieved with higher room temperature. This reduce air conditioning load required, and therefore, reduces the installation cost and system operating cost.

**Standby Cooling Capacity:** Energy stored in ITES can be utilized to cater peak or unexpected loads which exceeded total cooling capacity available from the installed chillers. This is savior to the regions which having difficulties on power generation plants expansion, where with ITES, will significantly reduced total demand of the buildings.

# MINIMUM CLEARANCE REQUIREMENTS

## Single Pit (See Note 2)

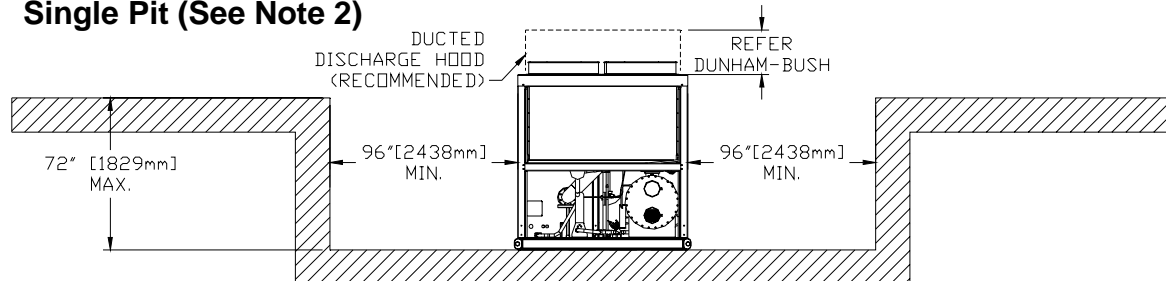

## Double Pit (See Note 2)

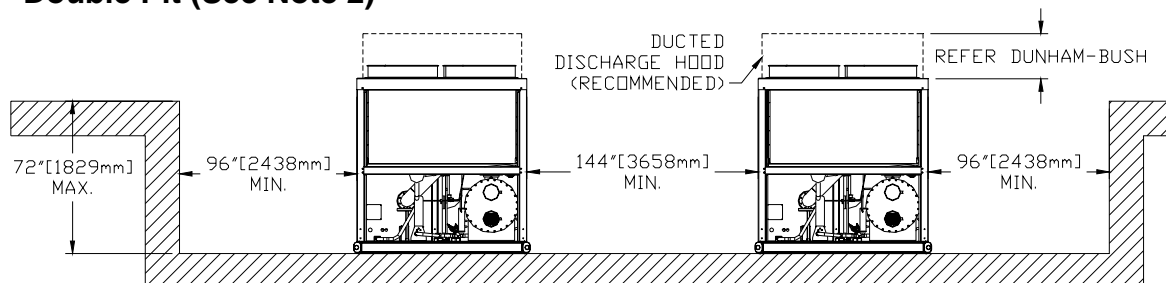

## Multi Pit

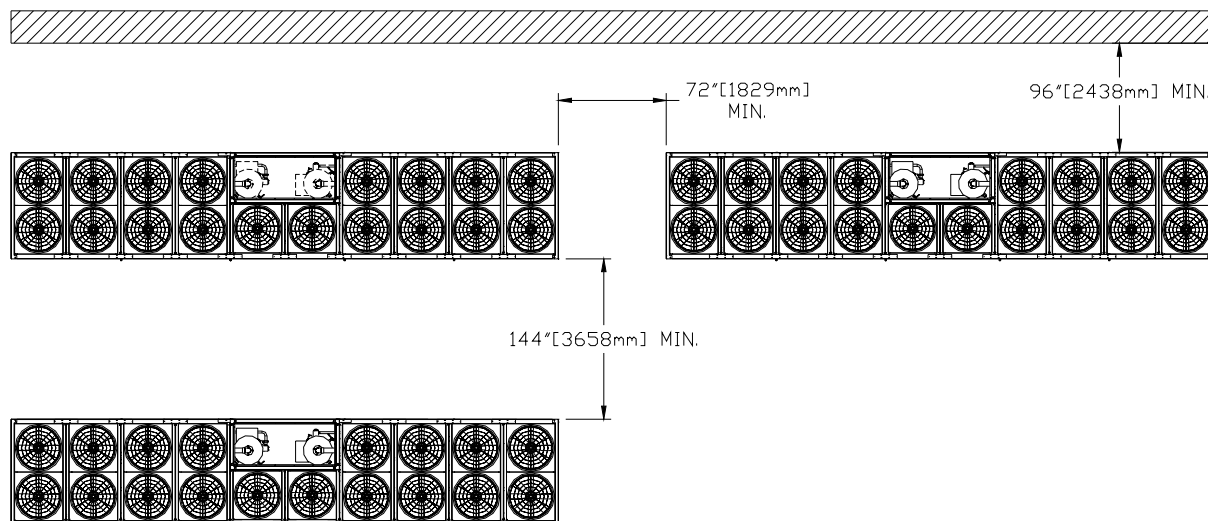

## Corner Wall

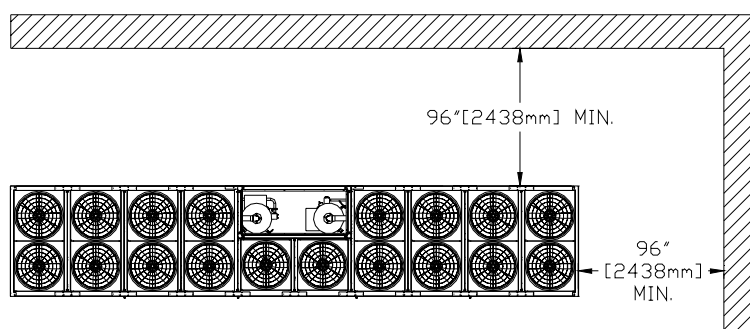

### Notes:

- 1.) All dimensions are minimal, unless otherwise noted.
- 2.) Pit installations are not recommended. Re-circulation of hot condenser air in combination with surface air turbulence cannot be predicted. Hot air re-circulation will severely affect unit efficiency (EER) and can cause high pressure or fan motor temperature trips. Dunham-Bush will not be responsible for ducting fans to a higher level to alleviate the above mentioned conditions.

# GUIDE SPECIFICATIONS

---

## 1.0 GENERAL

### 1.1 SUMMARY

Supply and commissioning of complete factory assembled air cooled screw chiller suitable for outdoor installation. The air cooled chiller shall contain rotary vertical screw compressor(s), evaporator, air cooled condenser with coil and fan, interconnecting refrigerant piping, electronic expansion valve, control panel, chilled liquid connections. The control panel shall be fully wired by the manufacturer to connect and interlock controller, starter, protection devices with electrical power and control connections. Packaged chiller shall be factory assembled, charged and run tested with a full operating refrigerant and oil charge. The refrigerant type shall be R134a and shall not have phasing out schedule.

Contractor shall furnish and install chiller as shown and scheduled on the drawings. Unit shall be installed in accordance with this specification.

### 1.2 QUALITY ASSURANCE

- ✿ Chiller performance shall be rated in accordance to AHRI 550/590 standard latest edition
- ✿ ASME standard B31.5 for Refrigerant piping
- ✿ Vessels shall be fabricated and pressure tested in accordance with ASME Boiler and Pressure vessel code, Section VIII, Division 1 "Unfired Pressure Vessels"
- ✿ Manufacturer shall have experience of minimum 15 years in manufacturing Air Cooled Screw Chillers in their facility
- ✿ Unit shall be manufactured in ISO9001 registered manufacturing facility
- ✿ [OPTIONAL] ASHRAE Standard 15 safety code for mechanical refrigeration
- ✿ [OPTIONAL] PED certification required in Europe market place
- ✿ Factory run test: Chiller shall be pressure tested, evacuated and fully charged with refrigerant and oil. The chiller shall be run tested with water flowing through the vessels
- ✿ Manufacturer shall have a service organization with trained service personal

### 1.3 DESIGN BASE

The construction drawings indicate a system based on a selected manufacturer of equipment and the design data available to the Engineer during construction document preparation. Electrical services, size, configuration and space allocations are consistent with that manufacturer's recommendations and requirements.

Other listed or approved manufacturers are encouraged to provide equipment on this project; however, it will be the Contractor and/or Supplier's responsibility to assure the equipment is consistent with the design base. No compensation will be approved for revisions required by the design base or other manufacturers for any different services, space, clearances, etc.

### 1.4 DELIVERY, STORAGE AND HANDLING

Unit shall be delivered to job site fully assembled with all interconnecting refrigerant piping and internal wiring ready for field installation and charged with refrigerant and oil by manufacturer. When delivered, machine shall be stored indoors, away from construction dirt, dust, moisture or any other hazardous material that would harm the chillers. Inspect under shipping tarps, bags, or crates to be sure there is no water collected during transit. Protective shipping covers shall be kept with the unit until machine is ready for installation.

### 1.5 WARRANTY

Chiller manufacturer's warranty shall cover for 12 months from the date of start-up or 18 months from the date of shipment whichever is first. The start-up shall be carried out by a authorized service personnel and the warranty is limited to part replacement excluding labor and consumables such as refrigerant, oil & filter driers etc.

### 1.6 MAINTENANCE

Maintenance of the chillers will be the responsibility of the owner and performed in accordance with the manufacturer's instructions

## 2.0 PRODUCTS

### 2.1 OPERATING REQUIREMENTS

The units will be furnished as shown on capacity schedules and drawings. Unit performance will be in accordance with AHRI Standard 550/590.

The unit shall be capable of starting up with entering fluid temperature to the cooler at 95°F [35°C].

The unit shall be capable to produce chilled fluid temperature between 40°F to 60°F [4.5°C to 15.6°C] at standard operating mode.

#### [OPTIONAL]:

- A. Dual Mode operation – The unit shall capable for ice thermal storage applications with supply brine temperature down to 18°F [-7.8°C].
- B. Low Temp. Operation – The unit shall capable for process cooling application with supply fluid temperature down to 18°F [-7.8°C].

The unit shall be design to operate at ambient temperature 45°F to 115°F [7°C to 46°C], with extended ambient temperature to 125°F [52°C] for high ambient operation.

#### [OPTIONAL]:

- A. Low Ambient Operation (LA1) – The unit shall capable to operate with ambient temperature down to 14°F [-10°C].
- B. Extra Low Ambient Operation (LA2) – The unit shall capable to operate with ambient temperature down to -20°F [-29°C].

Unit shall be able to operate with 3-phase 50/60Hz power supply with voltage within +/- 10% of unit rated voltage.

Control Voltage shall be 115V/1ph/ 50/60Hz.

# GUIDE SPECIFICATIONS

---

## 2.2 CONSTRUCTION

The unit panels, control boxes shall be constructed by heavy gauge, galvanized steel with powder coating baked finishing to pass 1000-hours salt spray test in accordance with ATSM B117 standard.

## 2.3 COMPRESSOR

The packaged chiller shall be furnished with direct drive, hermetic sealed, positive displacement rotary screw compressor(s), driven by a 3500 RPM-60Hz 2 pole motor.

Each compressor shall include integral oil separation system, oil sump and oil filter. The oil differential pressure shall be controlled during operation to maintain proper oil lubrication throughout the lubrication system. An electric oil heater shall be supplied with each compressor to maintain required oil temperature during shutdown period. The heater shall be energized when the chiller is switched off.

Each compressor shall have an oil level sight glass, suction check valve, suction filter and discharge service valve. Unit shall be provided with isolation valves to allow condenser to be used as a pump down receiver.

Compressor capacity control shall be obtained by Variable Frequency Driven motor in combination with slide valve at low load within each compressor. The bearing shall be heavy duty, anti-friction, anti-reverse tapered roller type, shall be able to carry both radial and thrust loads.

The compressor motor shall be hermetic refrigerant gas cooled, 2 pole, and squirrel cage induction type with class H insulation. Motor winding shall have thermistors embedded in the motor windings. The thermistors shall be wired to the solid state motor protection module to protect motor from overheating.

The compressor(s) shall be acoustically enclosed in a galvanized steel casings enclosure with perforated liner insulated with fiberglass for maximum sound absorption.

### [OPTIONAL]:

- A. Compressor Suction Service Valve – To further isolate compressor from evaporator.
- B. Compressor Acoustic Jacket - For unit operation which require further sound reduction.
- C. Flanged Semi-Hermetic Compressor – Semi-hermetic compressor shall be provided on request.

## 2.4 EVAPORATOR

Evaporator vessel shall be cleanable shell and tube, flooded type. Shell shall be fabricated from rolled carbon steel sheet with fusion welded seams or carbon steel standard pipes. End plates shall be of carbon steel with precision drilling, reamed in order to accommodate tubes. Intermediate tube support shall be in place to provide required tube support between tube sheets. Tubes shall be of copper, seamless, high efficient, internally enhanced and externally finned, mechanically expanded into fixed steel tube sheets.

Tube diameter shall be  $\frac{3}{4}$  inch and thickness shall be 0.025 inch. The flooded evaporator shall have a built in distributor for feeding refrigerant evenly under the tube bundle to produce a uniform boiling action and baffle plates shall be provided to ensure vapor separation.

Water box shall be removable type for tube cleaning. Water connections shall be with Victaulic grooves in compliance to ANSI / AWWAC-606. Vent and drain plugs are to be provided in water box. The shell side of the evaporator shall have pressure relief valve with provision for refrigerant venting.

Evaporator refrigerant side shall be designed and constructed in accordance with the ASME Code for Unfired Pressure Vessels. Evaporator shell side shall be designed for working pressure up to 200PSIG [13.8BAR] and undergo pneumatic pressure test at 220PSIG [15.2BAR]. Tube side shall be designed for 150PSIG [10.3BAR] working pressure and undergo hydrostatic pressure test at 195PSIG [13.4BAR].

The flooded evaporator shall have an efficient and reliable oil recovery system. The oil recovery system shall insure the evaporator is operating at peak efficiency at all times and provide optimal energy efficiency during extended periods of part load. Units without such oil recovery systems shall not be acceptable.

All low temperature surfaces shall be factory insulated with 1 inch [25mm] thick Polyethylene resin having K factor of 0.26 btu-in / hr.ft<sup>2</sup>.°F.

### [OPTIONAL]:

- A. Evaporator Flanged Water Connection – Flanged water connection shall be provided in lieu of Victaulic connection.
- B. Double Thick Insulation – Evaporator shall be provided with 2 inch [50mm] thick closed cell insulation for extra resistance to condensation.
- C. 250PSIG Working Pressure Vessel – Evaporator with 250PSIG working pressure on shell side shall be provided.
- D. PED Compliance – Evaporator with PED approval shall be provided for installation in European countries.

## 2.5 CONDENSER AND FANS

Condenser shall be Air cooled type with tube/fin coil design. The coil shall be constructed of seamless inner-grooved copper tube and die formed aluminum fins having self spacing collars in staggered configuration. Copper tubes shall be mechanically expanded into the fins.

The coil construction shall be of V configuration in order to increase heat transfer area and condenser divider baffles shall fully separate each condenser fan section to control the air flow by fan cycling and fan staging to maintain optimum head pressure. Coil plate shall be made of galvanized steel and divider baffles shall be made of galvanized steel with powder coating.

The fan shall be direct drive propeller type, made of heavy duty alloy blades, in order to have higher



# GUIDE SPECIFICATIONS

---

resistance for dust and sand abrasion. Fan shall be protected with powder coated steel wire fan guard.

The motor shall be 3-phase, TEFC or TENV, squirrel cage induction type with IP55 enclosure and class F insulation. The motor bearing shall be permanently lubricated. Motor shall have internal thermal protection.

The fan and the motor assembly shall be rigidly secured to the casing with a heavy gauge steel powder coated fan brackets with air discharge upward.

The coils shall be pneumatic leaked and pressure tested at 450PSIG [31BAR].

The condenser shall be sized for full pump down capacity.

## [OPTIONAL]:

- A. Pre-coated Aluminum fin/Copper tube coil – Copper tube/Pre-coated Aluminum fin construction shall be made of seamless inner grooved copper tubes mechanically expanded into pre-coated (hydrophilic coated) aluminum fins. The tube sheet shall be of galvanized steel and the divider baffles shall be of galvanized steel with powder coating
- B. Copper tube/Copper fin coil – Copper/Copper coil construction shall be made of seamless inner grooved copper tubes mechanically expanded into copper fins. The tube sheet shall be of galvanized steel or stainless steel and the divider baffles shall be of galvanized steel with powder coating.
- C. Post-coated Aluminum fin/Copper tube coil – Copper tube/post-coated Aluminum fin coil construction shall be made of seamless inner grooved copper tubes mechanically expanded into Aluminum fins. The tube sheet shall be of galvanized steel. The entire coil shall be coated with anti corrosive coating after the coil fabrication. The divider baffles shall be made of galvanized steel with powder coating.
- D. Protective Grille For Condenser Coil – Protective grille shall be provided to condenser coil section to prevent unauthorized access.
- E. Low Noise Operation – Low noise operation shall be provided to lower down unit operating sound level.
- F. VFD on Condenser Fans – Condenser fan motors shall be driven by VFD to further enhanced unit part load efficiency

## 2.6 REFRIGERANT CIRCUIT

The refrigerant circuit shall include discharge service valves, liquid line shut off valve, oil filter, replaceable filter drier, and sight glass at liquid line. Liquid line angle valve shall be provided for refrigerant charging. Pressure relief valves shall be provided at evaporator and compressor body.

The packaged chiller shall be furnished with electronic expansion valve for precise modulation of refrigerant flow control and improve efficiency by optimizing the suction and discharge superheat. In addition, the refrigerant control system shall optimized refrigerant liquid level in the flooded evaporator to protect the compressor from slugging liquid refrigerant. Fixed orifice control systems shall not be acceptable.

## [OPTIONAL]:

- A. Heat Recovery – Factory supplied shell-and-tube heat exchanger to reclaim waste heat from the system to produce hot water up to 131°F [55°C].
- B. Hotgas Bypass – Shall be factory for operation down to approximately 10% of full load

## 2.7 OIL MANAGEMENT

The chiller package shall ensure proper lubrication during the operation in order to have prolonged compressor life as well as maintaining system efficiency. An efficient pressure differential lubrication system shall be provided with oil filter, sight glass, oil sump and oil sump heater. The oil heater shall be energized during the chiller switched off to prevent oil from dilution. Oil pump shall not be acceptable.

## 2.8 ELECTRICAL AND CONTROL PANEL

The electrical switch gears, controller, sensor transmitters and relays shall be housed in IP54 panel. The panel casing shall be of galvanized steel with powder coating baked finishing for corrosion resistance. The panel shall be divided into two separate compartments or shall have two separate panels to house power and control devices separately.

The chiller manufacturer shall provide a Variable Frequency Drive (VFD) for each compressor motor which also minimize the starting current in addition to capacity modulation function. The VFD shall be factory mounted, wired to the motor and controller. The VFD shall be able to provide adequate starting torque and the required acceleration for the compressor during starting.

The electrical panel compartment shall include:

- A. Main incoming power terminal block suitable to receive single entry of three phase 3-wire power supply with specified voltage.
- B. Circuit breaker for each compressor
- C. Solid state compressor motor over current protection for each phase shall be inherent feature of Variable Frequency Drive
- D. Solid state compressor motor overheat protection module
- E. Under/over voltage phase reversal and imbalance relay.

The Variable Frequency Drive and circuit breakers shall be wired securely to the main incoming terminal block. Overheating protection modules, over/under voltage phase relay shall be interlocked with the compressor in order to provide adequate protection to the compressor motor.

## [OPTIONAL]:

- A. Single Power Connection Point – Single point connection point shall be provided for unit with modular design.
- B. Unit Mounted Main Disconnect Switch – Non-fused disconnect switch with external lockable handle shall be provided to isolate unit main incoming power supply for servicing.

# GUIDE SPECIFICATIONS

---

- C. Ground Fault Interrupt (GFI) – GFI shall be provided for ground fault protection of the unit.
- D. Ammeter / Voltmeter – Analog ammeter and voltmeter with 3-phase selector switch shall be provided for quick system voltage and current indication
- E. IP55 control panel – Option shall be offered to upgrade the standard IP54 control panel to IP55 rated.

## 2.9 CONTROLS

### 2.9.1 General

The packaged chiller shall be equipped with stand along proactive advance controller which adapts to abnormal operation conditions. The unit algorithm program and operating parameters shall be stored in flash-memory that does not require a battery back-up. Controller requires back-up battery is not acceptable.

115V power supply to the control circuit shall be provided by a factory mounted control transformer installed in the panel. External power source to the control circuit is not acceptable.

The controller shall be equipped with a user friendly terminal with 7" 64k color touch screen LED back light graphical display and dedicated touch keys that provides easy access to the unit operating parameters, control set points and alarm history. There shall be dedicated touch keys enable user to access information, based on security level of password. There shall be min three level of password for operator, service personnel and for the manufacturer for critical settings in order to protect the chiller controller from unauthorized access.

The controller shall be provided with a set of terminals that connected to various devices such as temperature sensors, pressure transducers, current transducers, solenoid valves, VFDs, electronic expansion valve, control relays. The controller should be able to be configured and connected multiple units that allow sequencing control without additional hardware. The controller shall be able to carry out all program operations. It shall be able to display unit operating parameters, compressor information, alarm history and shall able to modify the parameters.

The controller shall be able to carry out self-diagnostic test on the controller and the connected devices and alarm messages shall be displayed automatically on faulty devices.

All messages shall be displayed in English language. Readings and settings displayed shall be selectable between Imperial or SI units.

Leaving chilled water temperature control shall be accomplished by entering the water temperature set point with accuracy to 0.8°F and placing the controller automatic control mode. The controller shall monitor all control functions and modulate the VFD (and slide valve if required) to the calibrated position. The compressor loading cycle shall be programmable and shall be adjusted to the building load requirement. The

loading adjustable range shall be from 0.1% to 0.4% per increment to prevent excessive demand hike at start up.

The controller shall continuously monitor evaporator leaving water temperature, rate of change of chilled water leaving temperature, evaporator and condenser pressure; compressor amp draw; and discharge refrigerant temperature.

The controller shall be capable to accept low level remote control signal. Remote Start/Stop shall be provided as standard for unit start/stop by external on/off signal.

#### [OPTIONAL]:

Chilled Water Temperature Reset – The controller shall be capable to accept a 0 to 5VDC chilled water temperature reset signal to reset the chilled water supply temperature setpoint, based on external demand.

Demand Limit / Current Limit – The controller shall be capable to accept a 0 to 5VDC demand limit signal to limit the compressors operating current during the unit operation.

The electrical control panel shall be wired to permit fully automatic operation during - initial start-up, normal operation, and shutdown conditions. The control system shall contain the following control, displays and safety devices:

#### Unit Mounted Variable Frequency Drive (VFD)

Each compressor shall have dedicated VFD for capacity modulation and shall be operating in tandem with the chiller main controller.

The VFD shall be enclosed for outdoor use. The drive shall be able to operate with maximum output at 50°C ambient temp and humidity rage from 5% to 95%.

The Motor and power cables shall be mounted securely through glands in the base plate.

VFD shall be able to deliver 110% torque for 60 seconds during normal operation.

Supply voltage shall be 380–460V with +/-10% operating range.

VFD shall have numerical display which shall indicate power input, frequency, motor current and running hour.

VFD shall have inbuilt Electronic thermal motor protection against overload.

The frequency converter shall be protected against short-circuits on motor terminals U, V, W.

It shall also Protection against mains phase loss.

### 2.9.2 Automatic Controls

- ✿ Compressor motor increment contactors
- ✿ Start delay timer
- ✿ Anti-recycle timer
- ✿ Oil sump heater interlock relays
- ✿ Chilled water pump on/off control
- ✿ Programmable with Seven day operation cycle

# GUIDE SPECIFICATIONS

---

## 2.9.3 Manual Controls

- ✿ Auto/Local/Remote switch
- ✿ Control circuit stop and start switches
- ✿ Compressor enable switch

### [OPTIONAL]:

Dual mode changeover switch – Digital input to changeover unit operation from chiller mode to freezing mode.

## 2.9.4 Indicator Lights

- ✿ Compressor Motor high temperature
- ✿ Compressor motor overload
- ✿ System common alarm

The control system shall be provided with an anti-recycle device. The control shall limit compressor starting to a minimum of 15 minutes between starts.

## 2.9.5 Refrigerant Controls

- ✿ Refrigerant flow control shall be carried out electronically by a precision electronic expansion valve
- ✿ Compressor loading and unloading solenoid valves

## 2.9.6 System Information

The chiller display shall provide following operating information.

- ✿ Leaving chilled water temperature
- ✿ Entering Chilled water temperature
- ✿ Compressor discharge temperature
- ✿ Leaving chilled water temperature derivative
- ✿ Evaporator pressure
- ✿ Condenser pressure
- ✿ Ambient Temperature
- ✿ Compressor amps draw for each compressor
- ✿ Compressor elapsed run time of each compressor
- ✿ Compressor start status
- ✿ Oil level sensor status
- ✿ Water flow switch status
- ✿ External start/stop command status
- ✿ Percentage of compressor capacity
- ✿ Electronic expansion valve percentage of opening.
- ✿ Trend graph of leaving chilled water temperature

### [OPTIONAL]:

- ✿ Operating supply Voltage
- ✿ Chilled water temperature reset value
- ✿ Demand limiting value

## 2.9.7 Safety Protection

- ✿ Short circuit protection.
- ✿ Compressor motor over load protection (3 phase)
- ✿ Under or over voltage and phase failure relay
- ✿ Reverse rotation
- ✿ Compressor motor overheat protection
- ✿ High discharge temperature protection
- ✿ Low oil level protection via optical sensor
- ✿ High condenser pressure
- ✿ Low evaporator pressure
- ✿ Low differential pressure

- ✿ Freeze protection (low chilled liquid leaving temperature )
- ✿ Chilled water flow loss
- ✿ Compressor run error
- ✿ Power loss
- ✿ Sensor error
- ✿ Refrigerant loss
- ✿ Low Ambient Lockoff

Controller shall be able to retain up to 99 alarm histories complete with time of failure and all critical sensor readings. This aids service technicians in their trouble shooting task enabling downtime and nuisance trip-outs to be minimized.

## 2.9.8 Remote Monitoring (BMS Interfacing)

The controller shall be designed to make easy on BMS interfacing by just an optional add-on communication card.

Various communication protocols as below shall be offered for user's selection.

- ✿ Modbus RTU RS485 / TCP/IP
- ✿ BACnet TCP/IP / MsTP / PTP
- ✿ LONworks

## 2.9.9 Optional Accessories

Factory shall supply below accessories for customer's field installation.

- ✿ Evaporator Water Flow Switch – Weather tight flow switch with three options for customer's selection; Flow switch with CE mark; NEMA 1 and NEMA 4 rated flow switch.
- ✿ Rubber-In-Shear Isolators
- ✿ Spring Isolators

## 3.0 EXECUTION

### 3.1 INSTALLATION

Chiller shall be installed strictly according to manufacturer's recommendations as stipulated in the installation manual, drawings and tender documents. Care should be taken to provide necessary service clearance as required in the manufacturer's drawing. Install the strainers at the inlet to the evaporator to prevent debris or other particles entering to the evaporator during piping work and initial flushing the system. Required coordination to be done with the electrical contractor and the control contractors to ensure electrical supply and required communications links are established.

### 3.2 START-UP/ COMMISSIONING

Chiller shall be commissioned by a service representative from manufacturer or by their local representative. The service personnel shall be trained and authorized by the manufacturer for start up of the supplied units. The start-up shall include briefing operators on chiller operations and maintenance as well.



#### Malaysia

Lot 5755-6,  
Kidamai Industrial Park,  
Bukit Angkat,  
43000 Kajang,  
Selangor, Malaysia

Tel: +603-8924 9000  
Fax: +603-8739 5020

#### China

No. 1 Dunham-Bush Road,  
Laishan District,  
Yantai,  
Shandong Province,  
China 264003

Tel: +86-535-739 7888  
Fax: +86-535-739 7999

#### United Kingdom

8 Downley Road,  
Havant,  
Hampshire,  
England PO9 2JD

Tel : +44-23-9247 7700  
Fax: +44-23-9245 0396

#### United States of America

1800 SE 38th Avenue,  
Homestead,  
Florida 33035  
United States of America

Tel: +1(786)-800 9999  
Fax: +1(786)-527 3539

#### United Arab Emirates

Office # 2606,  
Fortune Executive Towers,  
Cluster T1, Jumeirah Lake Tower  
Dubai, UAE

Tel: +971-4-443 9207  
Fax: +971-4-443 9208

#### South Africa

No. 57 Sovereign Drive  
Route 21 Corporate Park  
Irene, Pretoria  
South Africa

Tel: +27-12-345 4202  
Fax: +27-12-345 4203

#### India

Unit no : 804 , 8th Floor  
Spaze Platinum Towers,  
Sector-47, Sohna Road,  
Gurgaon-122018, India

Tel: +91-124-414 4430

#### Indonesia

The Boulevard Office,  
3F2 Jl. Fachrudin No.5,  
Kp. Bali, Tanah Abang  
Jakarta Pusat - 10250, Indonesia

Tel: +62-21-2123 1392

#### Thailand

48/39 Soi Praditmanutham 19  
Praditmanutham Road,  
Lat Pharo, Bangkok 10230  
Thailand

Tel: +66-0-2610 3749  
Fax: +66-0-2610 3601

#### Singapore

2 Kallang Pudding Road  
#07-07 Mactech Building  
Singapore 349307

Tel: +65-6842 2012  
Fax: +65-6842 2013

#### Vietnam

10th Floor, Nam A Bank Tower,  
201-203 Cach Mang Thang 8 Street,  
District 3, Ho Chi Minh City,  
Vietnam

Tel: +84-8-6290 3108  
Fax: +84-8-6290 3109

**DUNHAM-BUSH®**

info@dunham-bush.com  
www.dunham-bush.com



Products that perform...By people who care

Manufacturer reserves the right to change specifications without prior notice.

M-S-04105D-1021