



Helios

Air Cooled Screw Chillers

ACHX-D 60Hz

Cooling Capacity: 94 to 249 TR (329 to 875 kW)



DUNHAM-BUSH®

Products that perform...By people who care

INTRODUCTION

For more than 100 years, Dunham-Bush has focused on innovative product development. Today, we provide a full portfolio of HVAC/R products from Fan Coil Units to large centrifugal chillers as well as many other innovative green solutions. Our commitment to innovation, matched with an aggressive attitude toward growth, makes Dunham-Bush a leader in global markets. Our product development is tailored to meet the specific needs of customers. No other HVAC/R manufacturer takes this approach to meeting your performance expectations.

HELIOS, ACHX-D Air Cooled Screw Flooded Chillers, have a cooling capacity range from 94 to 249 TR [329 to 875 kW] in 60Hz version using environmentally friendly refrigerant which includes HFC-134a and HFO-513A. The entire product line features energy efficiency, installation ease, control flexibility, high reliability and advanced DB Director controller. The ACHX-D series are certified to AHRI Standard 550/590 and the unit's performance easily exceeds ASHRAE Standard 90.1-2016.

TABLE OF CONTENT

Page No	Page No		
Introduction	2	Sound Pressure Data	10
Nomenclature.....	2	Dimensional Data.....	11
General Characteristics	3	Floor Loading Diagram.....	14
Unit Features	3	Field Power & Control Wiring Schematic.....	15
Options & Accessories.....	6	Application Data	16
Operating Benefits	7	Minimum Clearance Requirements	19
Physical Specifications	9	Guide Specifications.....	20
Electrical Data.....	10		

NOMENCLATURE

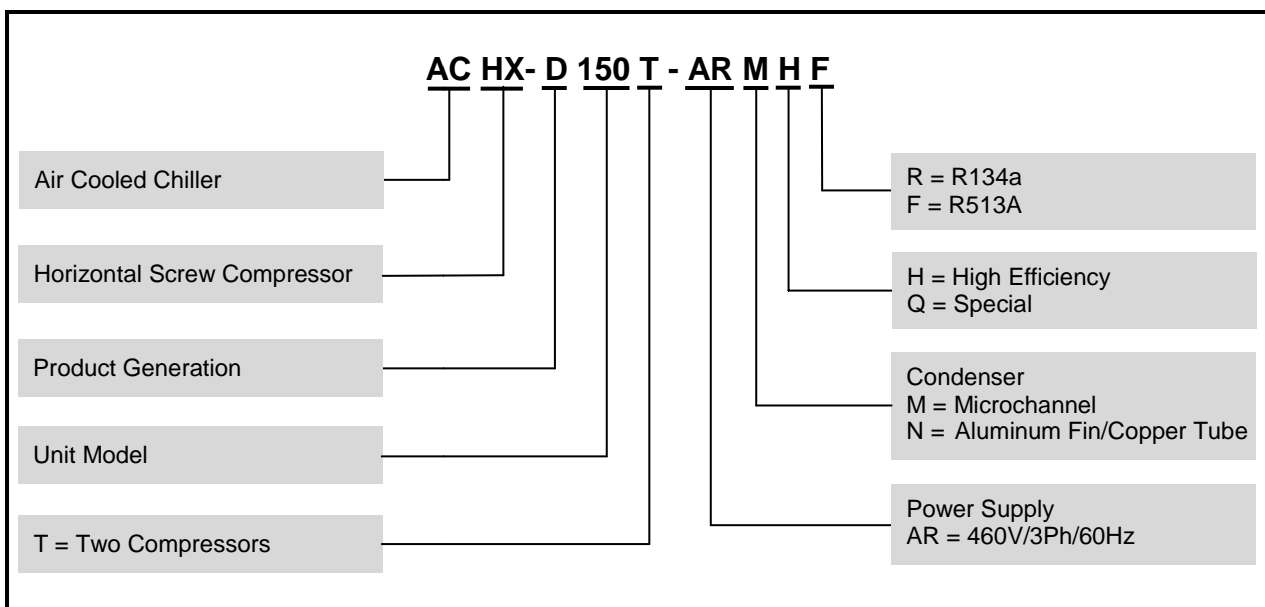

GENERAL CHARACTERISTICS

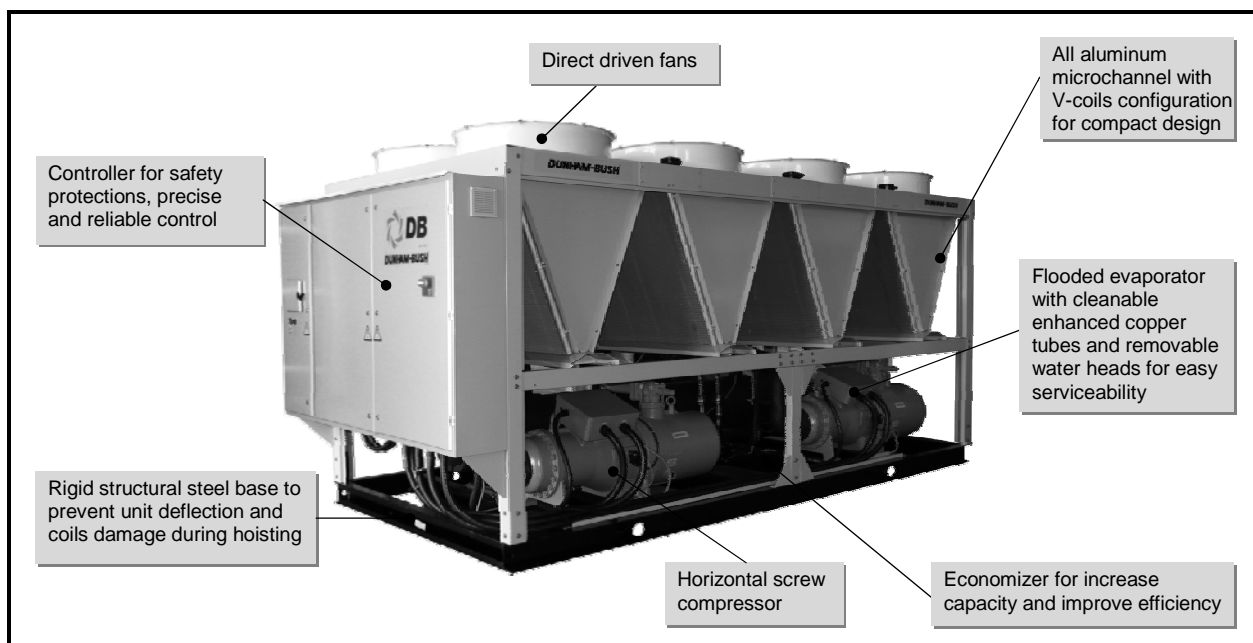

UNIT FEATURES

General

- ✿ 9 models from 94 to 249 TR [329 to 875 kW] in accordance with AHRI standard conditions
- ✿ Multiple compressors models with independent refrigerant system per compressor provide redundancy, and superior part load efficiency
- ✿ The unit is designed to operate with HFC-134a & HFO-513A. Both refrigerants are environment friendly refrigerant with zero **ODP** (Ozone Depletion Potential).
- ✿ Unit operating ambient temperature, 45~115°F [7~46°C]

Compressor

- ✿ Semi-hermetic Horizontal Screw Compressor
- ✿ Suction gas-cooled compressor motor
- ✿ Multiple rotary screw compressors design for better reliability and redundancy
- ✿ External oil pump not required
- ✿ Optimized oil management
- ✿ Integrated PTC sensor in each motor winding for thermal motor temperature monitoring
- ✿ Infinite variable capacity control with sliding valve mechanism
- ✿ Discharge service valve is provided for the ease of servicing

Evaporator

- ✿ Shell-and-tube flooded type heat exchanger
- ✿ Two pass arrangement

- ✿ Integral finned copper tubes to maximized heat transfer area
- ✿ Cleanable copper tubes for easy serviceability
- ✿ Removable water heads for service
- ✿ Victaulic groove water connection comply to ANSI/AWWA C-606
- ✿ Standard with 1" thick closed cell insulation
- ✿ Standard relief valve(s) – 3/4" [19mm] FPT
- ✿ Pressure test up to 220psig for refrigerant side, and 195psig for water side
- ✿ Isolation valves for refrigerant filter dryers are provided to allow filter core replacement without pump down the chiller. This greatly improve the servicing expenses and time

Condenser and Fans

- ✿ The Microchannel condenser coil is an all aluminum coils with multiple flat tubes containing small channels (Microchannels) metallurgically brazed with louvered fin.
- ✿ All Microchannel coils come with TCP-Coating which provides an anti-corrosion protective layer for the coil
- ✿ "V" coil design to increase condensing surface area to maximize heat rejection
- ✿ "V" coils arrangement with internal baffle for fan cycling and staging
- ✿ IP55, Class "F" insulation fan motors for outdoor applications

UNIT FEATURES

Electronic Expansion Valve

- ✿ Advanced electronic expansion valve (EEV) is used for precise control of liquid refrigerant flow into the evaporator
- ✿ Evaporation of liquid refrigerant in evaporator is controlled at precise level for optimum performance

Economizer

- ✿ The economizer circuit consists of plate type heat exchanger, expansion valve and solenoid valve
- ✿ Refrigerant is sub-cooled at economizer before entering the evaporator
- ✿ The economizer increased cooling capacity by means of increasing the sub-cooling
- ✿ Cooling capacity is increased significantly with marginal increases in kW-input, thus, unit EER is improved

Control Panel

- ✿ Weather tight electrical enclosure fabricated by heavy gauge sheet steel with powder coated baked finishing
- ✿ Single point power connection for all models
- ✿ Unit mounted reduced inrush starter for compressor motors
- ✿ Circuit breaker for compressors and condenser fan motors
- ✿ Step down transformer for power supply to control circuit
- ✿ Main power supply monitoring module. Protection on under or over voltage, phase reversal, phase losses and imbalance
- ✿ Unit mounted Remote/Off/Local (R/O/L) selector, an operation and servicing friendly feature
- ✿ Overload protection relay for compressors
- ✿ DB-Director – the state-of-art Dunham-Bush proactive advanced controller that adapts to any abnormal operating conditions and for safety protections
- ✿ Chilled water pump control

DB DIRECTOR

DB-Director is a rugged microprocessor based controller designed for the the HVAC/R applications. DB-Director provides flexibility with setpoints and control options that can be selected prior to commissioning a system or when the unit is live and functioning. Displays, alarms and other interfaces are accomplished in a clear and simple language that informs the user as to the status of the controller.

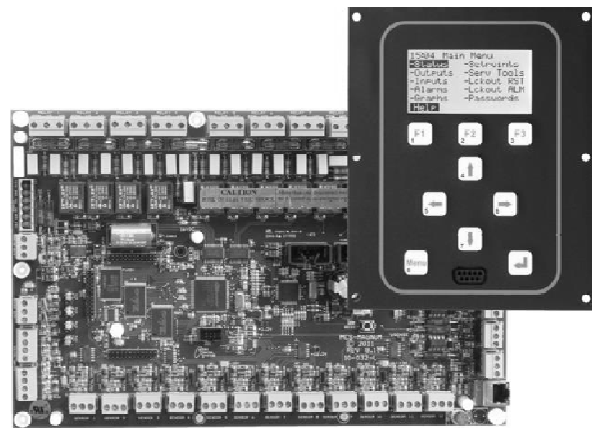

DB-Director is equipped with 128 x 64 pixels monochrome graphics LCD display with 2.8" diagonal viewing area, and 9 dedicated keys that enable user to access information, base on security level of the password. The user terminal is allows displaying and easy access to the unit working conditions, compressor run times, alarm histories and modify the parameters. Multiple messages will be displayed by automatically scrolling from each message to the next. All of these messages are spelled out in English language on the display terminal.

The display also has an automatically self-test of the controller on system start-up. For more detail operation of the DB-Director keypad, please refer to the Unit operation Manual.

Remote Monitoring For DB-Director

DB-Director is equipped with RS485 and Ethernet communication ports as standard. This user friendly design allows Building Management System (BMS) to interface directly with the chiller via either of Modbus RTU, Modbus IP, or BACnet IP communication protocol.

LONworks or BACnet MSTP communication protocol can be established with installation of external adapter.

UNIT FEATURES

Capacity Control

Leaving chilled water temperature control is accomplished by entering the water temperature setpoint and placing the controller in automatic control. DB Director monitors all control functions and moves the compressors slide valve to the required position to match the building cooling load demand.

The compressor ramp (loading) cycle is programmable and may be set for specific building requirements. Remote adjustment of the leaving chilled water setpoint is accomplished either through High Level Interfacing (HLI) via BMS communication, or Low Level Interfacing (LLI) via an external hardwired, 4 to 20mA chilled water reset control signal. Remote reset of compressor current limiting function can be accomplished in a similar fashion.

System Control

The unit may be started or stopped manually, or through the use of an external signal from a Building Automation System. In addition, the controller may be programmed with seven-day operating cycle or other Dunham-Bush control packages may start and stop the system through inter-connecting wiring.

System Protection

The following system protection controls will automatically act to ensure system reliability:

- ✿ Low evaporator pressure
- ✿ High condenser pressure
- ✿ Freeze protection
- ✿ Low suction-discharge pressure differential
- ✿ Low compressor oil level
- ✿ Compressor run error
- ✿ Power loss
- ✿ Chilled water flow loss
- ✿ Sensor error
- ✿ Compressor over current
- ✿ Compressor Anti-recycle
- ✿ High motor temperature
- ✿ Compressor overload

The controller can retain up to 99 alarm histories complete with time of failure together with data stamping on critical sensor readings in an alarm condition. This tool will aid service technicians in troubleshooting tasks enabling downtime and nuisance trip-outs to be minimized.

Remote Monitoring And Control (Option)

Dunham-Bush, the leader of HVAC solution provider understands the arising focus on chiller plant performance and optimization. Several solutions as below are offered to the building owner to achieved optimized chiller plant room controls, operation and performance.

Dunham-Bush Chiller Plant Manager (CPM)

DB Chiller Plant Manager (**CPM**) is a trustworthy and headache-free solution for building owners and users on chiller plant control and automation system. **CPM**'s advanced controllers monitor and control equipments in chiller plant such as chillers, primary and secondary chilled water pumps, variable frequency drives (VFD), motorized valves, bypass modulating valves, and etc. Field devices such as flow meters, BTU meters, digital power meters, sensors & transducers can be interfaced with **CPM** via HLI or LLI. CPM controls chillers and pumps sequencing, as well as lead-lag, duty-standby and alarm changeover operations.

NetVisorPRO – Monitoring software of **CPM** system which allows system monitoring, historical trending, and alarm logging to be carry out at a PC terminal. Graphical animations on system operation, temperature and flow rate trend graphs, historical data and alarm history logs, settings changes are all available with **NetVisorPRO**.

Chiller plantroom control and automation by Dunham-Bush **CPM** provides the owners with a chiller system in stable operation, optimized performance and energy efficiency.

DB-LAN Master Slave Sequencing Control (MSS)

In a chiller system with multiple Dunham-Bush chillers, DB Director controller of each chiller can be connected to the DB-LAN network via a communication bus without additional controller, to enable Master-Slave Sequencing Control of this chiller system. **MSS** will stage in/out chiller in operation to match building required cooling capacity. Chiller Lead-lag, duty-standby and alarm changeover controls are come with **MSS**, as well as the chilled water pumps control. Each **MSS** DB-LAN network can be connected up to 8 numbers of chillers.

Building Management System (BMS) Communication

DB Director is able to communicate to BMS through the add-on communication card via various common protocols as:

- ✿ Modbus RTU RS485, ModBus TCP/IP
- ✿ BACnet over IP, MS/TP, or PTP
- ✿ LONworks FTT10

OPTIONS AND ACCESSORIES

- ❖ **Heat Recovery** – The hot gas desuperheater; a shell-and-tube heat exchanger that reclaims ‘waste’ heat from compressor to produce hot water up to 131°F [55°C]
- ❖ **Microchannel Condenser enhanced Corrosion Protection** – Optional E-Coating which provides an enhanced anti-corrosion protective layer for microchannel coil for harsh environment
- ❖ **Fin and Tube Condenser** – Coil constructed of seamless inner grooved copper tubes expanded into die-formed aluminium slit fins
- ❖ **Fin and Tube Condenser Corrosion Protection** – Copper (CU) fin or coated fin for fin and tube coil are provided to give better corrosion protection.
- ❖ **Service valve** – Compressor suction service valve is supplied to further isolate the compressor from evaporator
- ❖ **Hotgas Bypass** – To maintain unit operation below minimum unloaded capacity
- ❖ **Low Ambient Operation (LA 1)** – Variable frequency drive (VFD) is incorporated to the condenser fan motor to allow unit operation down to 14 °F [-10 °C] ambient temperature
- ❖ **Extra Low Ambient Operation (LA 2)** – Add-on low ambient kit to allow unit operation down to -20°F [-29°C] ambient temperature
Note: Please consult factory for this option
- ❖ **Double Thick Insulation** – Evaporator with double thick 2” [50mm] closed cell insulation, for extra resistance to condensation
- ❖ **Evaporator Anti-Freeze Protection** – When chiller is not operating at ambient temperature 32°F [0°C] or below, the immersion heater and circulating pump will be in operation to prevent water freezing in evaporator (**Some of the model unit dimension may change for this option**)
- ❖ **250psig Working Pressure Vessel** – Evaporator with 250psig working pressure on water side
- ❖ **Condenser Coil Guard** – To protect condenser coil from unauthorized access
- ❖ **Evaporator Flanged Water Connection** – Flanged water connection is available as option
- ❖ **Dual Mode Operation** – The unit with dual mode operation can deliver chilled fluid temperature down to 18°F [-7.8°C] during ice making mode. Units with Dual Mode Operation is used for Ice Thermal Storage System
- ❖ **Low Temp. Operation** – The unit with Low Temp. Operation can deliver chilled fluid temperature down to 18°F [-7.8°C] for process cooling application
- ❖ **ASME Compliance** – Evaporator with ASME approval is available
- ❖ **BMS Communication** – Various add-on communication cards provide BMS communication via common protocols: Modbus RTU RS485 / TCP/IP, LONworks FTT10, BACnet over IP / MSTP / PTP

Electrical And Controls

- ❖ **Unit Mounted Main Disconnect Switch** – Non-fused disconnect switch with external lockable handle is furnished to isolate unit main incoming power supply for servicing
- ❖ **Ground Fault Interrupt (GFI)** – Provides equipment with ground fault protection
- ❖ **Ammeter/ Voltmeter** – Analog ammeter and voltmeter with 3 phase selector switch for indication, located inside the control panel
- ❖ **Chilled Water Reset/ Demand Limiting** – Low level interfacing with Building Automation System (BAS). Chilled Water Reset allows controlled temperature setpoint to be reset by a 4-20mA signal from BAS; while Demand Limiting will limit the maximum current drawn by the compressors by 4-20mA signal from BAS
- ❖ **Ambient Temperature Monitoring** – Temperature sensor to monitor unit operating ambient temperature
- ❖ **System Voltage Measurement** – System voltage option is a safety features to protect system from high and low voltage due to unbalance power supply. The controller will trigger alarm high or low voltage and cut-off running system
- ❖ **IP55 Control Panel** – IP55 rated control panel can be supplied for harsh working environment
- ❖ **Touch Screen Colour Panel** – 10” touch screen for display and user configuration
- ❖ **BMS Communication** – Various add-on communication cards provide BMS communication via common protocols: Modbus RTU RS485 / TCP/IP, LONworks FTT10, BACnet over IP / MSTP / PTP

Factory Supplied, Field Installed By The Customer

- ❖ **Evaporator Water Flow Switch**– Flow switch to be installed at evaporator outlet piping as safety interlock to evaporator water flow status. Three options are available: Weather tight flow switch with CE mark; NEMA 1, and NEMA 4 rated flow switch
- ❖ **Rubber-In-Shear Isolators** – Designed for ease of installation. These one-piece molded rubber isolators are applicable for most installations
- ❖ **Spring Isolators** – These housed spring assemblies have a neoprene friction pad at the bottom to prevent the passage of noise, and a spring locking levering bolt at the top. Neoprene inserts prevent contact between the steel upper and lower housings. Suitable for more critical application as compared to rubber-in-shear isolator

OPTIONS AND ACCESSORIES

- ✿ **DB-LAN Master Slave Sequencing Control (MSS)**
– Pre-programmed at factory; field supplied and installed inter-connection wiring between chillers to provide communication bus among chillers' controllers to enable Master-Slave Sequencing Control
- ✿ **Chiller Plant Manager (CPM)** – Factory supplied control panel; field supplied and installed interconnection wiring and field devices; for complete chiller plantroom automation

OPERATING BENEFITS

EFFICIENCY AND RELIABILITY

Energy Efficiency

- ✿ Designed to provide the greatest amount of cooling for the least power input over the entire operating range of your building
- ✿ Delivers outstanding efficiency and total energy savings through the utilization of economizer cycle and advanced controller staging; to produce greater capacity with fewer compressors
- ✿ Maximized performance through computer-matched components and multiple compressors
- ✿ High efficiency oil recovery system guarantees removal of oil carried over in the refrigerant and maintains the heat exchangers at their maximum efficiency at both full and part load

Refrigerant Compatibility

- ✿ Designed to operate with environmentally sound and economically smart HFC-134a and HFO-513A with proven efficiency
- ✿ Consult Factory for use of other refrigerants.

Flooded Evaporator

- ✿ Flooded evaporator design that fully utilized and maximized the heat transfer area available in the evaporator; operates with lower suction superheat, smaller evaporator approach. These have greatly improved efficiency of chiller with flooded evaporator.
- ✿ Flooded evaporator water heads can be removed easily without dismantling the chilled water piping connections, for inspection and for mechanical tubes cleaning with brushes or auto-brush. This will enable low tube fouling factor in the evaporator to be ensured, thus maintaining system efficiency

Operational Advantages

- ✿ Dramatic payback in reduced maintenance and overhaul costs both in downtime and in labor expenditures
- ✿ Ease of troubleshooting through controller retention of monitored functions

Factory Testing

- ✿ Each chiller undergoes the factory testing prior to unit shipment. This assures consistencies of workmanship at highest quality
- ✿ Thus, all units shipped are completely factory tested; charged and adjusted according to the design parameters, for ease of installation and minimal field start-up adjustments

Control Flexibility

- ✿ Controller-based with DDC controller (direct digital control) features precise push button control over every aspect of operation with built-in standard features that maximized energy savings on start-up and throughout the life of your equipment
- ✿ Ensured uniform compressor loading and optimal energy efficiency through controller to controls which utilize pressure transducers to measure evaporator and condenser pressure
- ✿ Lower energy costs resulting from automatic load monitoring and increased accuracy and efficiency in compressor staging
- ✿ Various communication options for remote monitoring of the unit operation
- ✿ Proactive control anticipates problems and takes corrective action before they occur. Controls will unload compressor(s) if head or suction pressure approach limits. This will enable unit to stay on line while warning operator of potential problems
- ✿ Stable and efficient operation with precise chilled water temperature control. Chilled water temperature is controlled at ± 0.8 °F [0.5 °C] range for your comfort cooling, with best energy saving

REFRIGERATION CYCLE

Dunham-Bush rotary screw air cooled chillers are designed for efficiency and reliability. The rotary screw compressor is a positive displacement, variable capacity compressor that will allow operation over a wide variety of conditions.

The refrigerant management system is shown in the refrigerant cycle diagram.

OPERATING BENEFITS

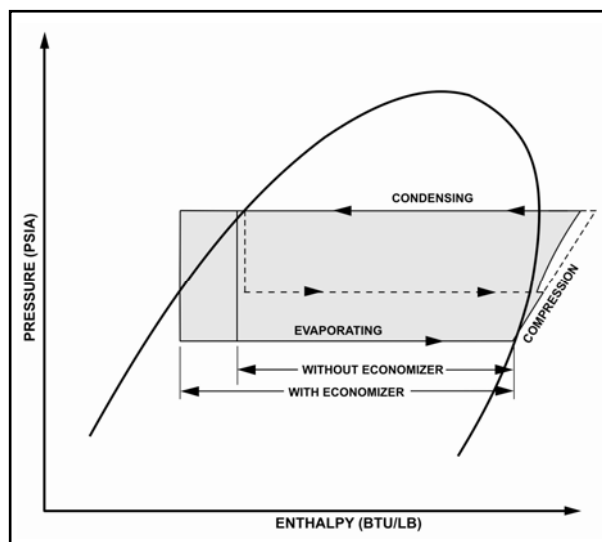

Liquid refrigerant enters the flooded evaporator uniformly where it absorbs heat from water flowing through the evaporator tubes. The vaporized refrigerant is then drawn into the suction port of the compressor where the positive displacement compression begins.

This partially compressed gas is then combined with additional gas from the vapor injection port at an intermediate pressure. Compressed gaseous refrigerant is then discharged into the integral oil separator where oil, which is contained in the refrigerant vapor, is removed and returned to the oil sump.

Fully compressed and superheated refrigerant is then discharged into the condenser, where air is being drawn through the condenser tube by the propeller fan cools and condenses the refrigerant. The liquid refrigerant then passes through the economizer. A portion of liquid refrigerant is tapped passes through the expansion valve back into the economizer for further subcooling of main liquid refrigerant flow.

The gaseous refrigerant is then drawn out of the economizer and into the vapor injection port of the compressor. The remaining subcooled liquid refrigerant then passes through electronic expansion valve which reduces refrigerant pressure to evaporator levels where it is then distributed evenly into the evaporator.

With the additional subcooling, the enthalpy of the refrigerant flowing into the evaporator is reduced which increases the refrigeration effect and improves the efficiency of the refrigeration cycle.

Economizer/ Vapor Injection Cycle for Increase Capacity and Higher EER

The renowned Dunham-Bush screw compressor allows for economizer vapor injection cycle to be incorporated, increasing capacity by significantly with marginal increase in kW-input. Thus, unit EER is improved!

PART-LOAD PERFORMANCE

Through the use of economizer, electronic expansion valve and multiple compressors, Dunham-Bush air cooled chillers have some of the best part-load performance characteristics in the industry when measured in accordance with AHRI Standard 550/590.

In most cases, actual building system loads are significantly less than full load design conditions, therefore chillers operate at part load most of the time.

Dunham-Bush air cooled chillers combine the efficient operation of compressors with economizer cycle and advanced controller to yield the best total energy efficiency and significant operating saving under any load.

When specifying air conditioning equipment, it is important to consider the system load characteristics for the building application. In a typical city, the air conditioning load will vary according to changes in the ambient temperature. Weather data compiled over many years will predict the number of hours that equipment will operate at various load percentages.

The Air Conditioning and Refrigeration Institute (AHRI) has established a system, in AHRI Standard 550/590, for measuring total chiller performance over full and part-load conditions. It defines the Integrated Part-Load Value (IPLV) as an excellent method of comparing diverse types of equipment on an equal basis. The IPLV is a single number estimate of a chiller's power use weighted for the number of hours the unit might spend at each part-load point. IPLV's are based on Standard Rating Conditions.

The formula for calculating an IPLV is:

$$IPLV = \frac{1}{\frac{0.01}{A} + \frac{0.42}{B} + \frac{0.45}{C} + \frac{0.12}{D}}$$

where: **A= kW/ton at 100% load point**
B= kW/ton at 75% load point
C= kW/ton at 50% load point
D= kW/ton at 25% load point



PHYSICAL SPECIFICATIONS

Model ACHX-D		100T	120T	140T	160T	180T	200T	220T	240T	260T
Cooling Capacity	TR	93.55	115.62	131.15	154.92	169.05	188.22	214.13	230.48	248.68
	kW	329	407	461	545	595	662	753	811	875
Power Input	kW	104.0	127.8	145.2	175.0	190.0	210.6	236.6	253.6	282.1
Energy efficiency	kW/TR	1.111	1.105	1.107	1.129	1.124	1.119	1.105	1.100	1.134
COP	kW _e /kW _i	3.165	3.183	3.178	3.114	3.129	3.143	3.183	3.197	3.100
Screw Compressor										
QTY.		2	2	2	2	2	2	2	2	2
RPM		3550	3550	3550	3550	3550	3550	3550	3550	3550
Oil Charge	Litres	28	32	32	32	32	32	34	36	46
Min. % Unit Capacity Reduction		12.5	12.5	12.5	12.5	12.5	12.5	12.5	12.5	12.5
No. Of Refrigerant Circuit		2	2	2	2	2	2	2	2	2
Evaporator										
Model		C5R(T)	1CR(T)	1DR(T)	2ER(T)	2FR(T)	2FR(T)	EBR(T)	JCR(T)	JCR(T)
(Qty)		1	1	1	1	1	1	1	1	1
Water Connector	inches	4	5	5	6	6	6	6	8	8
	mm	101.6	127	127	152.4	152.4	152.4	152.4	203.2	203.2
Nominal Water Flow	Usgpm	224.5	277.5	314.8	371.8	405.7	451.7	513.9	553.1	596.8
	l/s	14.2	17.5	19.9	23.5	25.6	28.5	32.4	34.9	37.7
Nominal Water Pressure Drop	ft.wg	6.7	22.4	20.7	20.9	19.0	22.9	23.4	19.5	22.2
	kPa	20.1	66.9	62.0	62.3	56.7	68.5	70.0	58.2	66.5
Min. Water Flow	Usgpm	159.9	116.8	138.3	162.9	187.5	187.5	210.6	252.1	252.1
	l/s	10.1	7.4	8.7	10.3	11.8	11.8	13.3	15.9	15.9
Max. Water Flow	Usgpm	532.9	389.4	461.1	543.1	625.1	625.1	701.9	840.3	840.3
	l/s	33.6	24.6	29.1	34.3	39.4	39.4	44.3	53.0	53.0
Min. Water Pressure Drop	ft.wg	3.7	4.7	4.8	4.8	4.8	4.7	4.7	4.8	4.7
	kPa	11.0	14.2	14.2	14.2	14.2	14.2	14.1	14.2	14.2
Max. Water Pressure Drop	ft.wg	32.0	41.4	41.5	41.5	41.6	41.4	41.3	41.6	41.4
	kPa	95.7	123.8	124.0	124.1	124.3	123.6	123.6	124.3	123.8
Condenser										
Total Air Flow	CFM	102,648	102,648	102,648	102,648	153,972	153,972	153,972	179,634	205,296
	CMH	174,399	174,399	174,399	174,399	261,598	261,598	261,598	305,198	348,798
Total Face Area	sq.ft	188.8	188.8	188.8	188.8	283.2	283.2	283.2	330.4	377.7
	sq.m	17.54	17.54	17.54	17.54	26.31	26.31	26.31	30.70	35.09
No. of Fans		8	8	8	8	12	12	12	14	16
Fan Motor HP		3	3	3	3	3	3	3	3	3
General										
Unit Length	inches	197 1/4	197 1/4	197 1/4	197 1/4	287 13/16	287 13/16	287 13/16	333	378 3/8
	mm	5010	5010	5010	5010	7310	7310	7310	8460	9610
Unit Width	inches	89	89	89	89	89	89	89	89	89
	mm	2260	2260	2260	2260	2260	2260	2260	2260	2260
Unit Height	inches	94	94	94	94	94	94	94	94	94
	mm	2390	2390	2390	2390	2390	2390	2390	2390	2390
Shipping Weight	lbs	7868	8473	8779	9084	10988	11163	11711	13160	14944
	kg	3569	3843	3982	4121	4984	5064	5312	5969	6778
Operating Weight	lbs	8073	8673	9005	9356	11289	11464	12058	13576	15360
	kg	3662	3934	4084	4244	5121	5200	5469	6158	6967
Operating Charge	lbs	170	201	231	262	293	324	355	386	417
	kg	77	91	105	119	133	147	161	175	189

Notes: 1. Nominal capacity is based on evaporator in/out fluid temperature at 54/44°F, ambient temperature 95°F, evaporator fouling factor 0.0001ft².h.°F/Btu.
 2. The above specifications is based on **microchannel** condenser coils.
 3. To consult nearest Dunham-Bush sales office for computer selections other than above operating conditions

ELECTRICAL DATA

Model ACHX-D	Power Supply : 460Vac-3Ph-60Hz											
	Compressor Data					Condenser Fan Motor Data			Unit Data			
	Starter Type	Qty	RLA	Starting Current	LRA	Qty	HP	FLA	RLA	MCA	MFS	Max Inrush
100T	Star-Delta	2	63	182	545	8	3	4	158	173	225	261
120T	Star-Delta	2	80	218	655	8	3	4	192	212	250	314
140T	Star-Delta	2	93	268	805	8	3	4	217	240	300	376
160T	Star-Delta	2	114	317	950	8	3	4	260	288	400	447
180T	Star-Delta	2	119	393	1180	12	3	4	285	315	400	536
200T	Star-Delta	2	134	393	1180	12	3	4	315	349	450	551
220T	Star-Delta	2	153	420	1260	12	3	4	353	391	500	596
240T	Star-Delta	1	153	420	1260	6	3	4	379	422	500	646
	Star-Delta	1	171	470	1410	8	3	4				
260T	Star-Delta	2	180	508	1525	16	3	4	422	467	600	719

Note: RLA - Running Load Amps At 95 °F Ambient Temperature; MCA - Minimum Circuit Ampacity; MFS - Maximum Fuse Size; LRA - Lock Rotor Amp

SOUND PRESSURE DATA

Model ACHX-D	Octave Band (Hz)								Total dB(A)
	63	125	250	500	1K	2K	4K	8K	
100T	36	38	53	59	62	58	49	41	65
120T	36	38	61	63	63	58	50	41	68
140T	36	38	53	65	62	60	56	55	68
160T	36	38	53	67	60	59	52	46	69
180T	37	39	61	65	65	59	52	43	70
200T	37	39	61	65	65	59	52	43	70
220T	37	39	57	66	66	60	52	44	70
240T	38	39	57	65	67	60	52	44	70
260T	38	40	56	64	69	60	52	43	71

Note: Unit Sound Pressure Level (Lp) @ 33 ft [10m] (free field), ± 2 dB(A) tolerance.

DIMENSIONAL DATA

2.4 DIMENSIONAL DATA

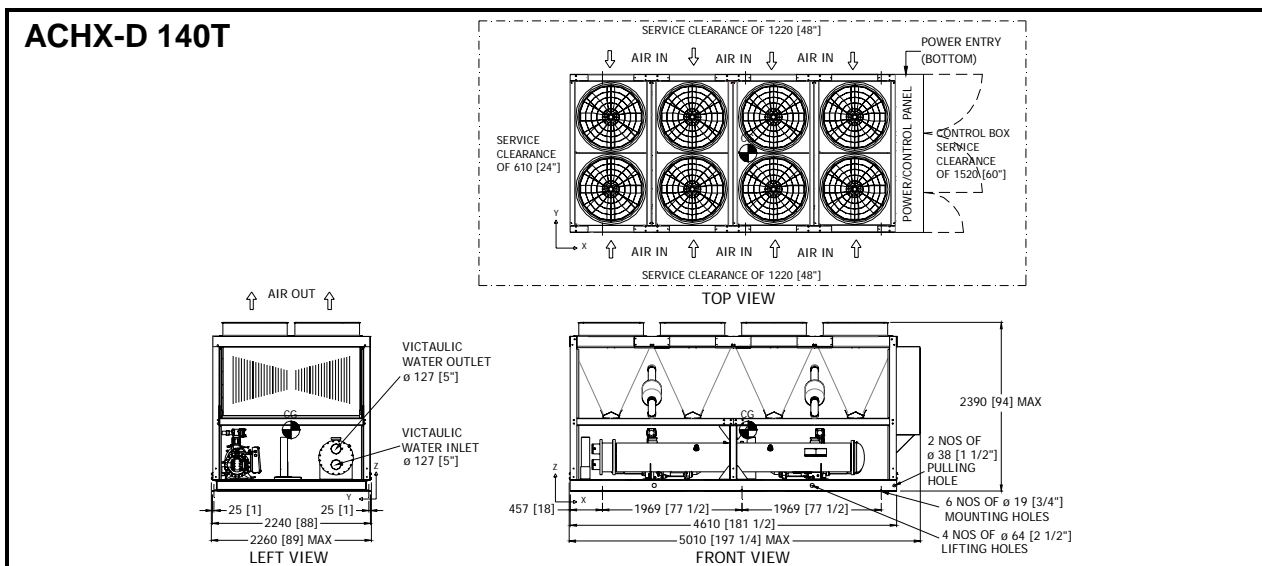
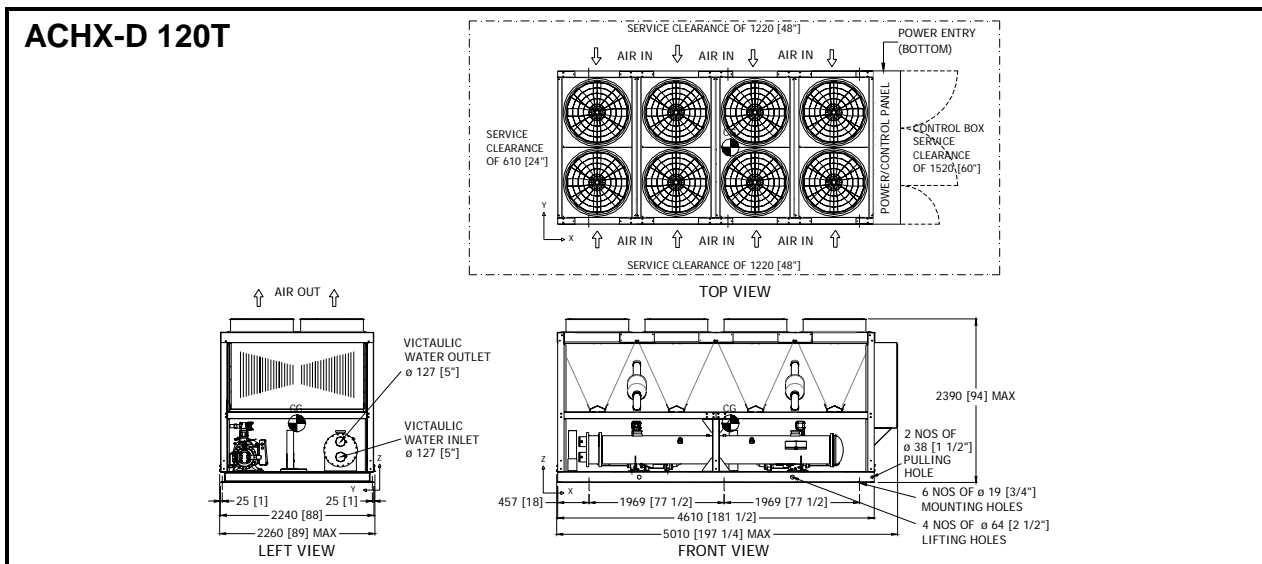
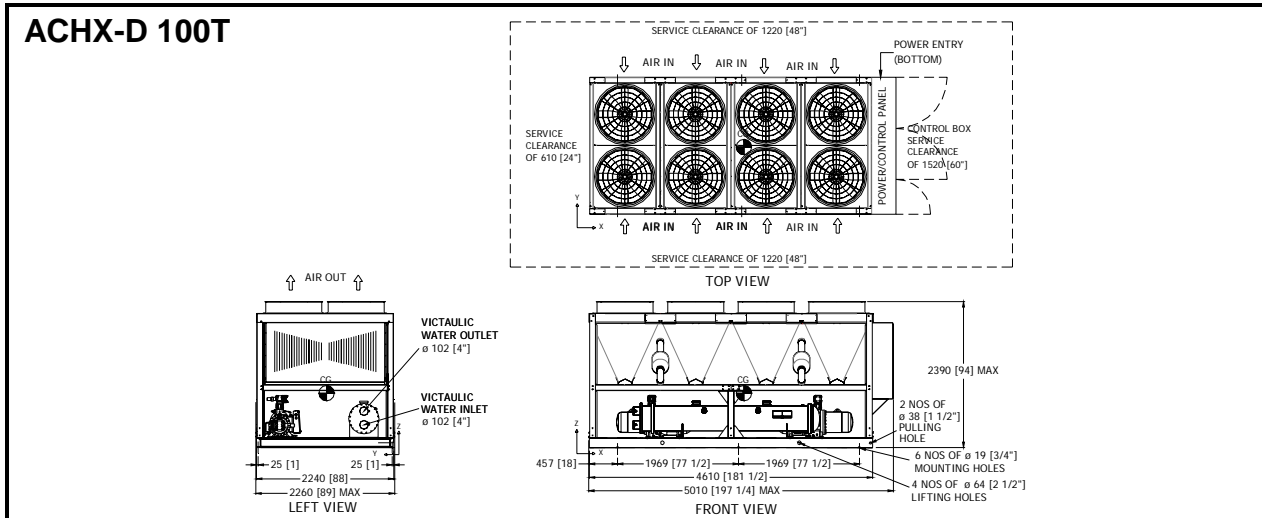

Note: All dimensions are in mm[inches].

DIMENSIONAL DATA

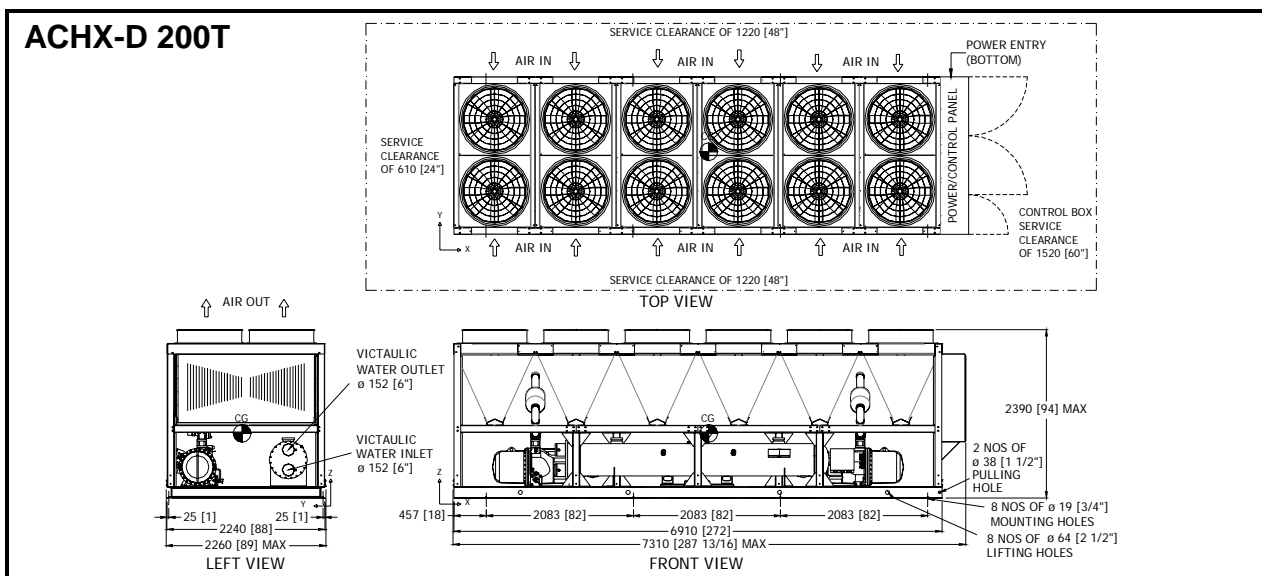
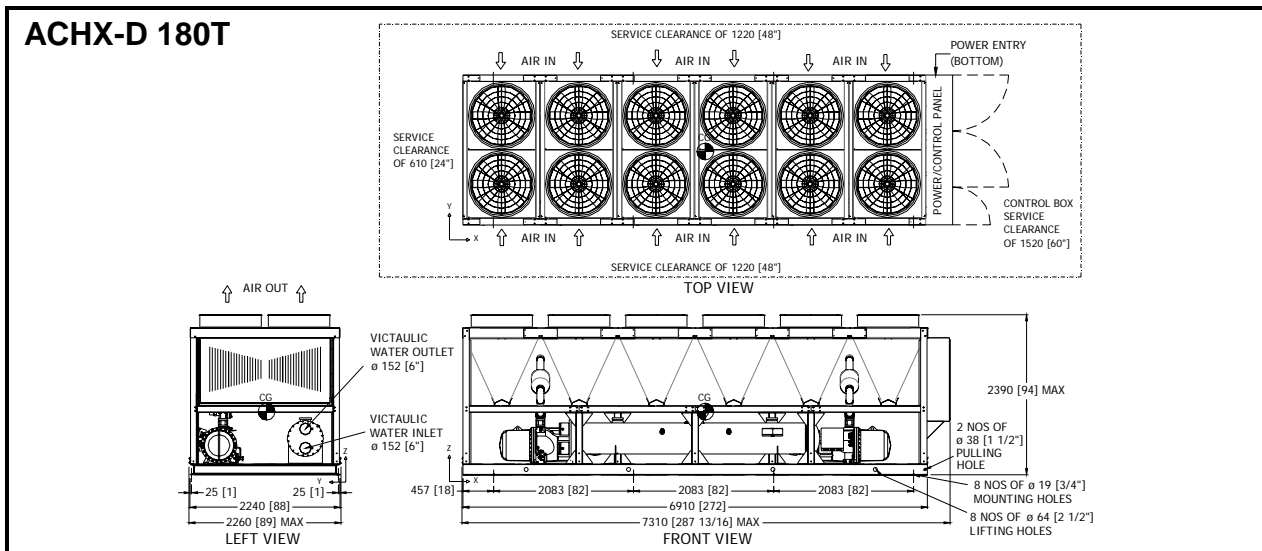
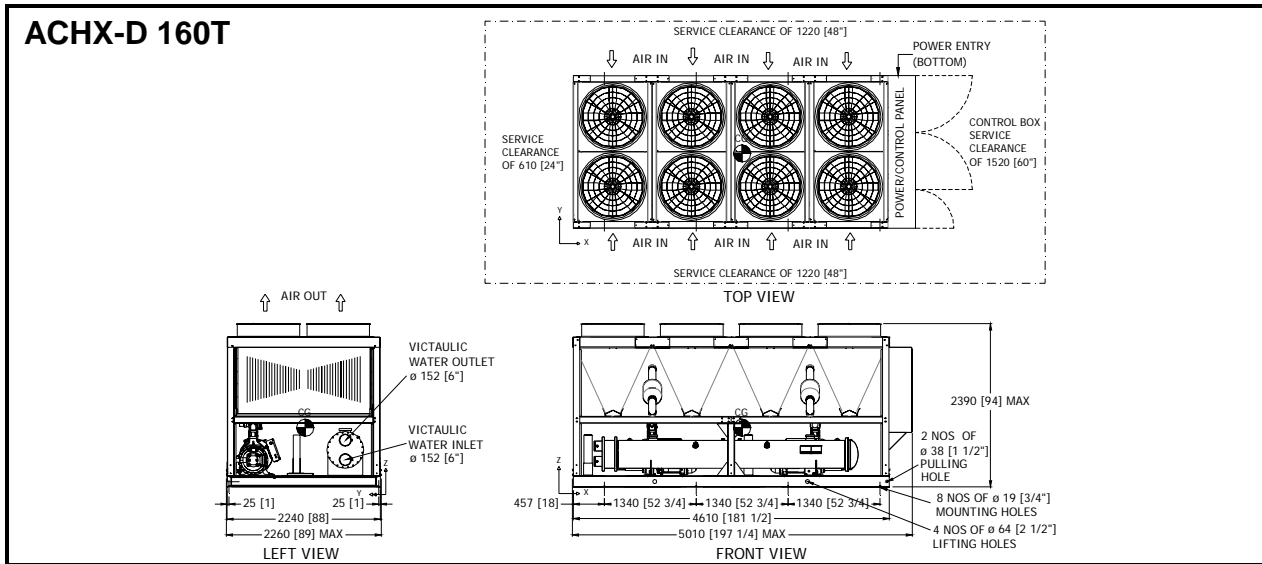

Note: All dimensions are in mm[inches].

DIMENSIONAL DATA

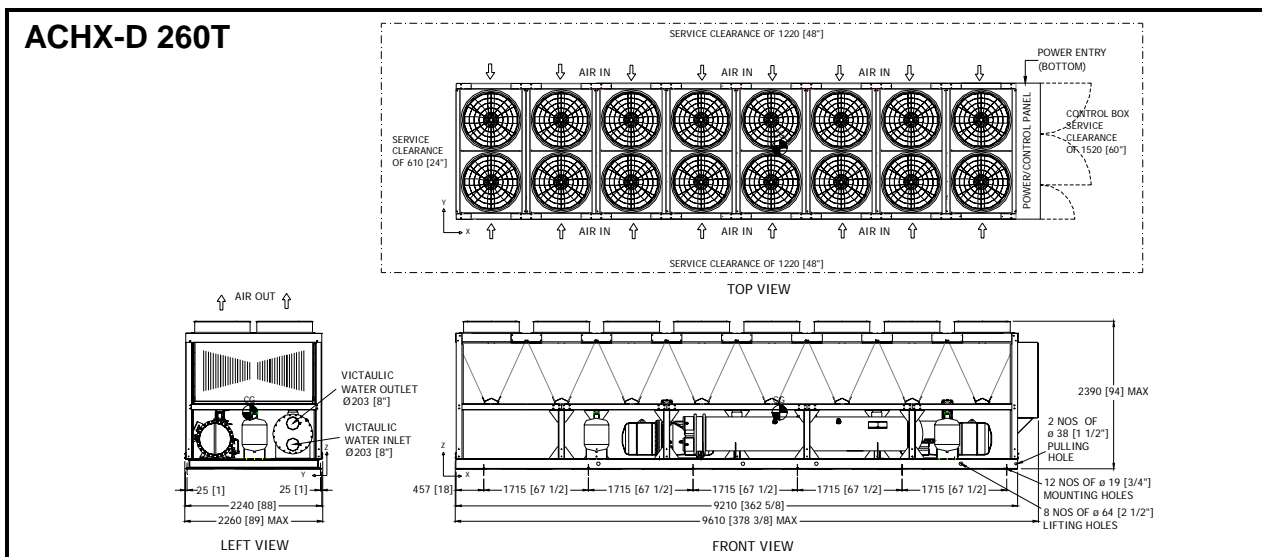
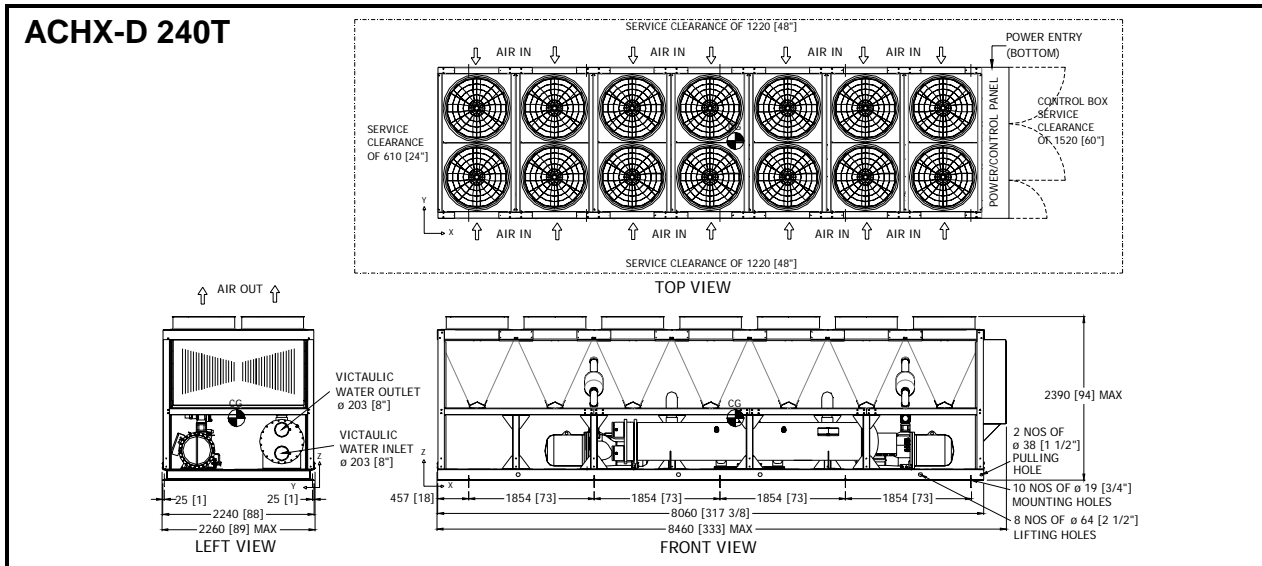
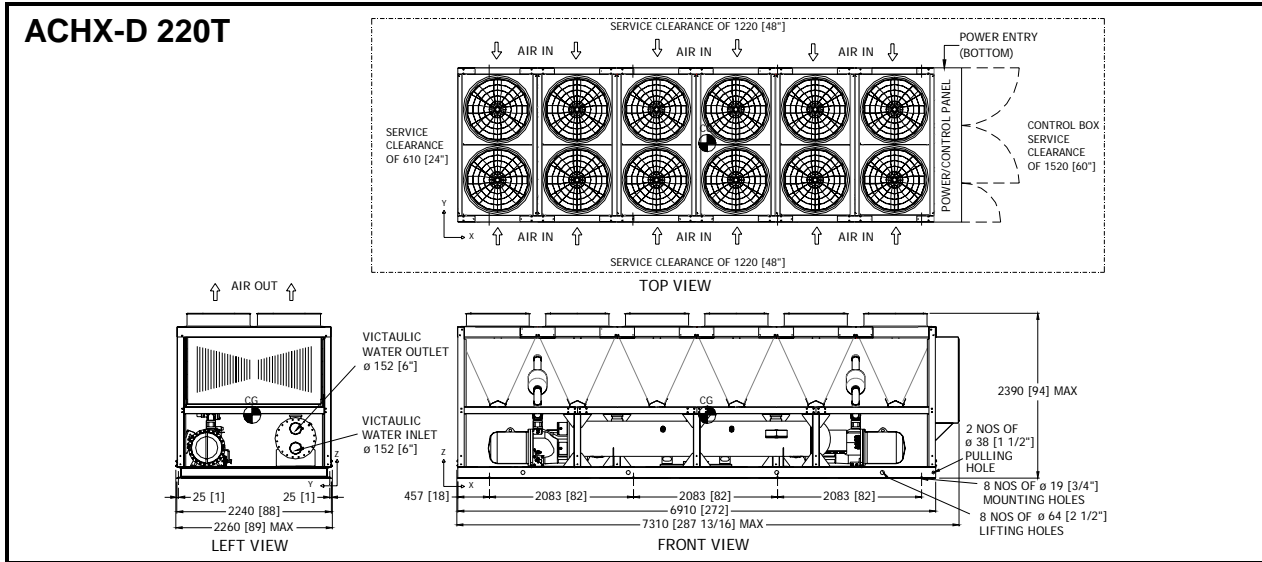

Note: All dimensions are in mm[inches].

FLOOR LOADING DIAGRAM

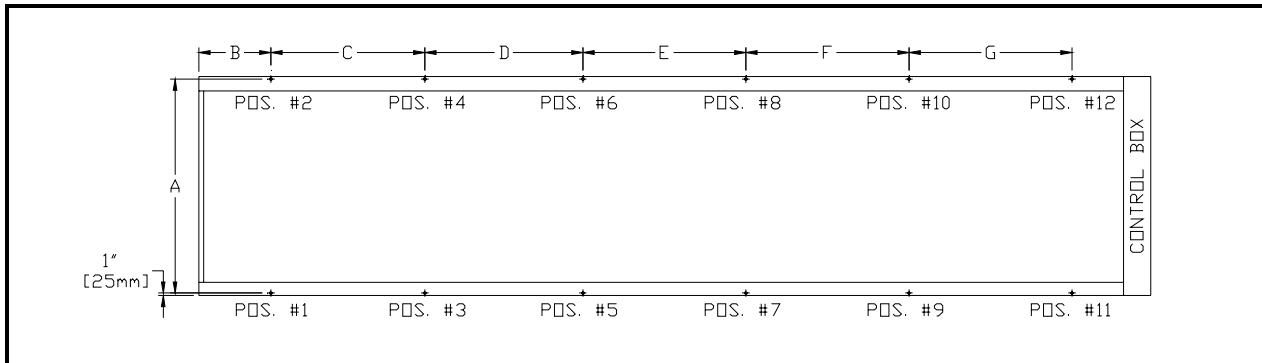

a.) Point Load Location

Model ACHX-D		A	B	C	D	E	F	G
100T	inches	86	18	77 1/2	77 1/2	21 13/16	22 2/16	-
	mm	2184	457	1969	1969	554	562	-
120T	inches	86	18	77 1/2	77 1/2	21 13/16	22 2/16	-
	mm	2184	457	1969	1969	554	562	-
140T	inches	86	18	77 1/2	77 1/2	21 13/16	22 2/16	-
	mm	2184	457	1969	1969	554	562	-
160T	inches	86	18	52 3/4	52 3/4	52 3/4	18 9/16	-
	mm	2184	457	1340	1340	1340	471	-
180T	inches	86	18	82	82	82	22 3/16	-
	mm	2184	457	2083	2083	2083	564	-
200T	inches	86	18	82	82	82	22 3/16	-
	mm	2184	457	2083	2083	2083	564	-
220T	inches	86	18	82	82	82	22 3/16	-
	mm	2184	457	2083	2083	2083	564	-
240T	inches	86	18	73	73	73	73	21 8/16
	mm	2184	457	1854	1854	1854	1854	546
260T	inches	86	18	67 1/2	67 1/2	67 1/2	67 1/2	67 1/2
	mm	2184	457	1715	1715	1715	1715	1715

b.) Point Load Data

Model ACHX-D		P1	P2	P3	P4	P5	P6	P7	P8	P9	P10	P11	P12	Total Operating Weight
100T	lbs	1246	1344	1550	1261	1270	1402	-	-	-	-	-	-	8073
	kg	565	609	703	572	576	636	-	-	-	-	-	-	3662
120T	lbs	1464	1454	1447	1482	1431	1395	-	-	-	-	-	-	8673
	kg	664	659	656	672	649	633	-	-	-	-	-	-	3934
140T	lbs	1485	1526	1467	1623	1435	1469	-	-	-	-	-	-	9005
	kg	674	692	665	736	651	667	-	-	-	-	-	-	4084
160T	lbs	1208	1256	1074	1158	1368	1247	908	1137	-	-	-	-	9356
	kg	548	570	487	525	620	566	412	516	-	-	-	-	4244
180T	lbs	1042	1410	1620	1445	1831	1577	1028	1338	-	-	-	-	11289
	kg	472	639	735	655	831	715	466	607	-	-	-	-	5121
200T	lbs	1055	1425	1647	1479	1860	1607	1039	1352	-	-	-	-	11464
	kg	479	646	747	671	843	729	471	613	-	-	-	-	5200
220T	lbs	1094	1473	1783	1543	2025	1681	1069	1389	-	-	-	-	12058
	kg	496	668	809	700	919	763	485	630	-	-	-	-	5469
240T	lbs	847	778	1509	2058	1493	1153	2041	1524	928	1245	-	-	13576
	kg	384	353	685	934	677	523	926	691	421	565	-	-	6158
260T	lbs	788	812	985	1064	1658	1786	1300	1139	1881	1669	961	1315	15360
	kg	357	368	447	483	752	810	589	517	853	757	436	597	6967

FIELD POWER & CONTROL WIRING SCHEMATIC

TYPICAL FIELD WIRING DIAGRAM

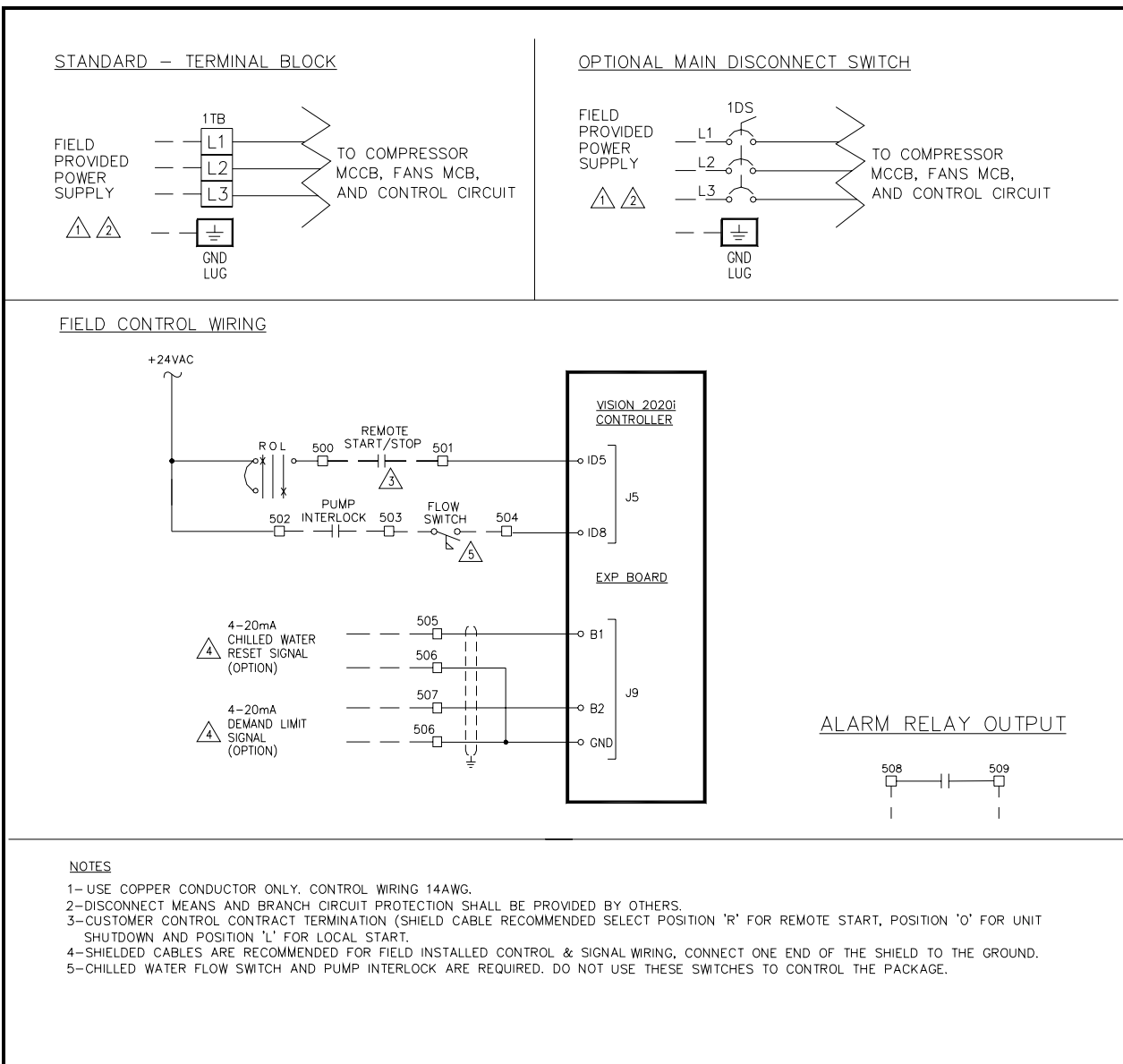

NOTES

- 1- USE COPPER CONDUCTOR ONLY. CONTROL WIRING 14AWG.
- 2- DISCONNECT MEANS AND BRANCH CIRCUIT PROTECTION SHALL BE PROVIDED BY OTHERS.
- 3- CUSTOMER CONTROL CONTRACT TERMINATION (SHIELD CABLE RECOMMENDED SELECT POSITION 'R' FOR REMOTE START, POSITION 'O' FOR UNIT SHUTDOWN AND POSITION 'L' FOR LOCAL START.
- 4- SHIELDED CABLES ARE RECOMMENDED FOR FIELD INSTALLED CONTROL & SIGNAL WIRING, CONNECT ONE END OF THE SHIELD TO THE GROUND.
- 5- CHILLED WATER FLOW SWITCH AND PUMP INTERLOCK ARE REQUIRED. DO NOT USE THESE SWITCHES TO CONTROL THE PACKAGE.

APPLICATION DATA

UNIT DESIGNED OPERATING RANGE

Unit Operating Range – Ambient Temperature

The units are designed to operate at ambient temperature, 45~115°F [7~46°C]. If the unit requires to be operated at lower ambient temperature, the optional Low Ambient Operation (LA 1), or Extra Low Ambient Operation (LA 2) shall be incorporated for stable operation.

Operating Limits – Ambient Temperature

Operating Ambient Temperature	Minimum	Maximum
Standard	45°F [7°C]	115°F [46°C]
With LA 1	14°F [-10°C]	115°F [46°C]
With LA 2	-20°F [-29°C]	115°F [46°C]

If wind velocity in the area is over 5 mph [8 kmph], wind barrier is recommended.

Unit Operating Range – Evaporator Temperature

The unit is designed to deliver chilled fluid temperature within 40~50°F [4.5~10°C]. The unit can start and pull down with up to 80°F [27°C] entering-fluid temperature. For sustained operation, it is recommended that the entering fluid temperature not exceed 70°F [21°C].

For unit installation with minimum ambient temperature at 32°F [0°C] or below, Evaporator Anti-Freeze Protection option is recommended to prevent freezing of water in evaporator when the chiller is not in operation.

Operating Limits – Leaving Fluid Temperature

Leaving Fluid Temperature	Minimum	Maximum
Standard	40 °F [4.5 °C]	50 °F [10 °C]
Dual Mode / Low Temp. Operation	18 °F [-7.8 °C]	50 °F [10 °C]

EVAPORATOR FLUID CIRCUIT

Wide Range ΔT - Low Flow Applications

Multiple smaller chillers may be applied in series, each providing a portion of the design temperature range typical 10°F [5.5°C] each.

Chilled fluid may be recirculated through the evaporator as shown below to allow the chiller to operate with acceptable flow rates and temperature ranges (Figure 1A).

Figure 1A

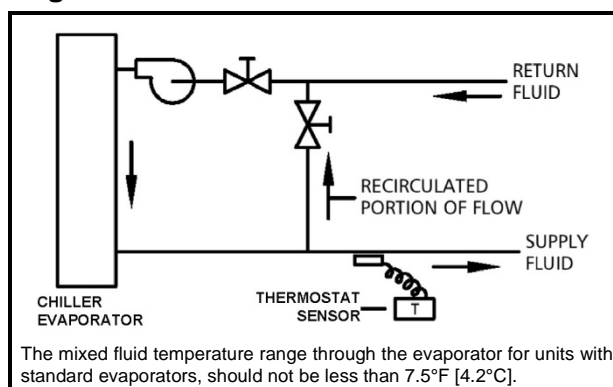

Narrow Range ΔT - High Flow Applications

For Narrow Range ΔT applications, a partial evaporator bypass piping and valve configuration can be used as shown below.

This permits a higher ΔT and lower ΔP (pressure drop) through the evaporator (Figure 1B).

Figure 1B

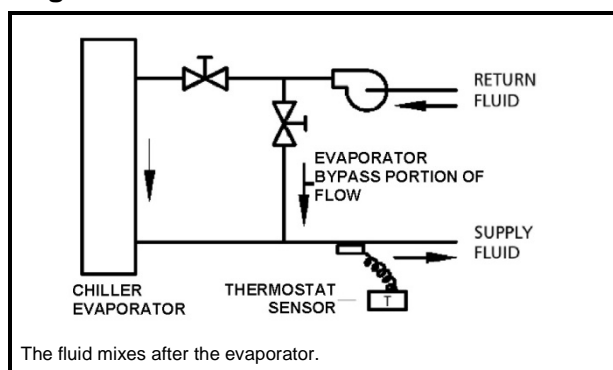

Minimum Chilled Fluid Loop Volume

The evaporator fluid circuit requires a minimum system fluid volume of 3 US gallons per Ton [3.3 liters/ cooling kW] for stable operation. The minimum system fluid volume may increasing up to 10 US gallons per Ton [11 liters/ cooling kW] for process cooling, low load applications with small temperature range and/or vastly fluctuating load conditions.

Tanks for System Volume Enhancement

It may be necessary to install a tank in the system to provide sufficient system fluid volume, as shown below. The tank should be baffled and piped for proper fluid mixing to prevent stratification.

Figure 2A

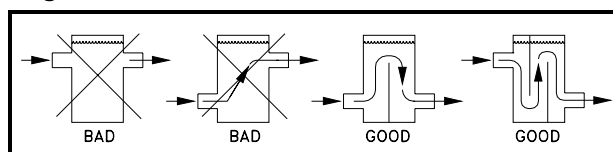

APPLICATION DATA

Figure 2B Single Loop System with Storage Tank to Increase Loop Volume

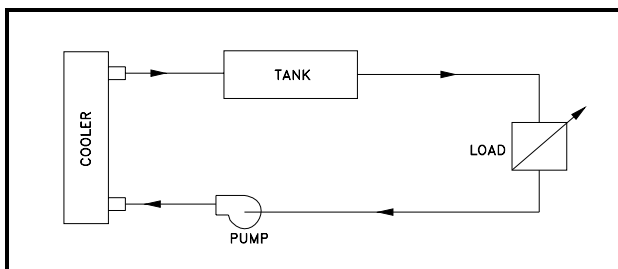
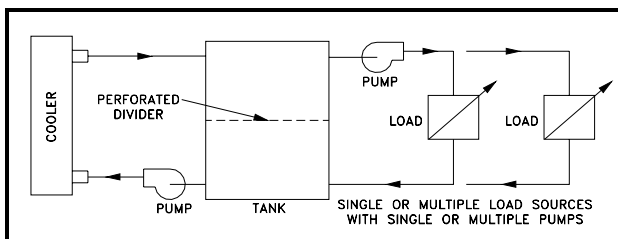

Figure 2C Primary and Secondary Loop Systems are normally used where the secondary system has variable flow and/or multiple loads. See example below.



Multiple Chillers In A Chilled Water System

Where the load is greater than available from one Helios ACHX-D, where standby capacity is required or the load profile dictates, multiple chillers may be piped in parallel. Units of equal size help to ensure fluid flow balance, but balancing valves ensure balanced flows even with dissimilar sized chillers.

Temperature controller sensors may or may not need to be moved to the common fluid piping depending on the specific application.

Parallel Chiller Applications – Both units operate simultaneously modulating with load variations. Each unit operates independently sensing its own leaving fluid temperature. The set point of each thermostat is set to maintain the desired loading scheme. (Figure 3A)

Figure 3A

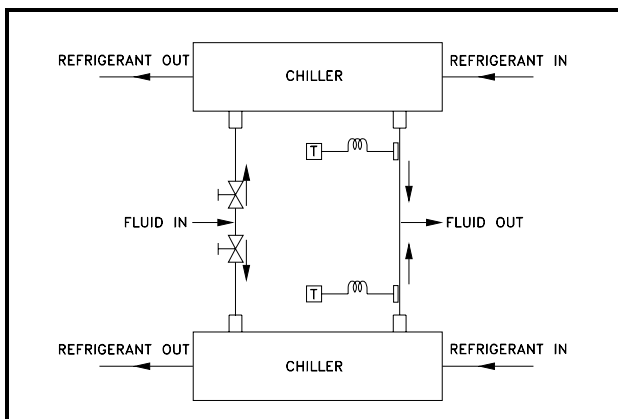

Series Chiller Applications – Where a large temperature range is required (over 25 °F [13.9 °C]), the chiller may be piped in series. In this case the units are controlled independently. The load is progressive by temperature so the chiller selections are critical. (Figure 3B)

Figure 3B

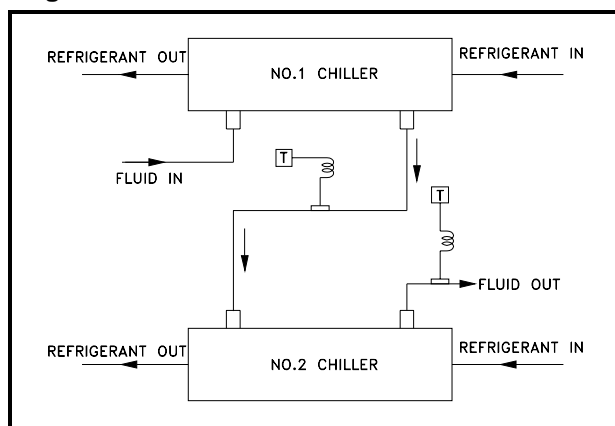

Variable Evaporator Flow

Dunham-Bush chillers are capable for variable evaporator flow system. The chiller may operate to maintain constant leaving fluid temperature with evaporator flow rate changes, with below conditions fulfilled.

- ⚙ Evaporator fluid flow rate is within minimum and maximum flow rate of the unit at all time during the operation
- ⚙ Rate of flow changed shall not exceeded 10% per minute

Failure to comply with the above conditions will cause problem to the chiller operation and may cause the chiller to shutdown.

Glycol Freeze Protection

If the chiller or fluid piping may be exposed to temperatures below freezing, glycol protection is recommended if the water is not drained. The recommended protection is 10°F [5.6°C] below the minimum ambient temperature in the equipment room and around piping. Use only glycol solutions approved for heat exchanger duty. DO NOT use automotive anti-freezing.

If the equipment is being used to supply chilled fluid 38°F [3.3°C] or below, glycol should be used to prevent freeze damage. The freeze protection level should be 15°F [8.3°C] lower than the leaving brine temperature. The use of glycol causes a performance derate as shown below which needs to be included in the unit selection procedure.

APPLICATION DATA

Table 1 : Ethylene Glycol

% E. G. By Weight	Freeze Point		C1 Capacity Factor	K1 kW Rate	G1 Flow Factor	P1 P.D. Factor
	°F	°C				
10	26.2	-3.2	0.995	0.998	1.019	1.050
15	22.4	-5.3	0.991	0.997	1.030	1.083
20	17.8	-7.9	0.988	0.996	1.044	1.121
25	12.6	-10.8	0.984	0.995	1.060	1.170
30	6.7	-14.1	0.981	0.994	1.077	1.219
35	0.0	-17.8	0.977	0.992	1.097	1.275
40	-10.0	-23.3	0.973	0.991	1.116	1.331
45	-17.5	-27.5	0.968	0.990	1.138	1.398
50	-28.9	-33.8	0.964	0.989	1.161	1.466

Table 2 : Propylene Glycol

% P. G. By Weight	Freeze Point		C2 Capacity Factor	K2 kW Rate	G2 Flow Factor	P2 P.D. Factor
	°F	°C				
10	26.1	-3.3	0.988	0.994	1.005	1.019
15	22.8	-5.1	0.984	0.992	1.008	1.031
20	19.1	-7.2	0.978	0.990	1.010	1.051
25	14.5	-9.7	0.970	0.988	1.015	1.081
30	8.9	-12.8	0.962	0.986	1.021	1.120

Table 3 : Correction Factor - Elevation

Elevation above Sea Level		Capacity Correction Factor	kW Correction Factor
Feet [m]	Meters Factor		
0	0	1.00	1.00
2000	600	0.99	1.01
4000	1200	0.98	1.02
6000	1800	0.97	1.03

Table 4 : Correction Factor - FF

Fouling Factor		Capacity Correction Factor	kW Correction Factor
Hr.ft ² .°F/BTU	m ² .°C/kW		
0.0001	0.018	1.000	1.000
0.00025	0.044	0.993	0.997
0.00050	0.088	0.978	0.990
0.00100	0.176	0.951	0.978

Note: P.D. – Pressure drop across evaporator

ICE THERMAL STORAGE SYSTEM (ITES)

The globe is progressively marching towards a serious electric energy crisis. The HVAC/R industry is shifting to operate with more efficient machines, as well as alternate system designs and solutions. Dunham-Bush, as a leader of HVAC/R solutions provider, we provide packaged solution for ITES, which include, equipments selections, chillers, Ice Cels and CPM for ITES system controls.

Dunham-Bush Chillers, with positive displacement rotary screw compressor can easily cool low temperature glycol down to 20°F [-6.7 °C] to charge the ice storage tanks. The same chiller can also produce warmer supply fluid temperature, 40 to 45 °F [4.4 to 7.2 °C], for those building systems designed for only peak shaving.

Dunham-Bush is the only HVAC/R manufacturer who can provide complete ITES packaged solution, with own products for chillers, ice storage tanks and plant room control system, with following benefits.

Demand Charge: ITES allows some of the peak demand to be shifted to low-demand nighttime periods, thus reducing demand charges for the entire year.

Energy Cost: ITES, by operating chillers at night, will fully utilize incentive on electricity night tariff, which is much lower compare to day tariff

Rebates: ITES usually qualifies for rebates offered by electric utilities or governments for equipment that shift peak loads to off-peak hours

Colder Air Temperature: ITES can produce chilled liquid at supply temperature of 38°F [3.3°C] or even lower without scarifying system's efficiencies. This realizes energy saving on chilled water pumping system, AHUs and FCUs. Colder supply air distribution lowers room humidity, and thus, comfort cooling can be achieved with higher room temperature. This reduce air conditioning load required, and therefore, reduces the installation cost and system operating cost.

Standby Cooling Capacity: Energy stored in ITES can be utilized to cater peak or unexpected loads which exceeded total cooling capacity available from the installed chillers. This is savior to the regions which having difficulties on power generation plants expansion, where with ITES, will significantly reduced total demand of the buildings.

MINIMUM CLEARANCE REQUIREMENTS

Single Pit (See Note 2)

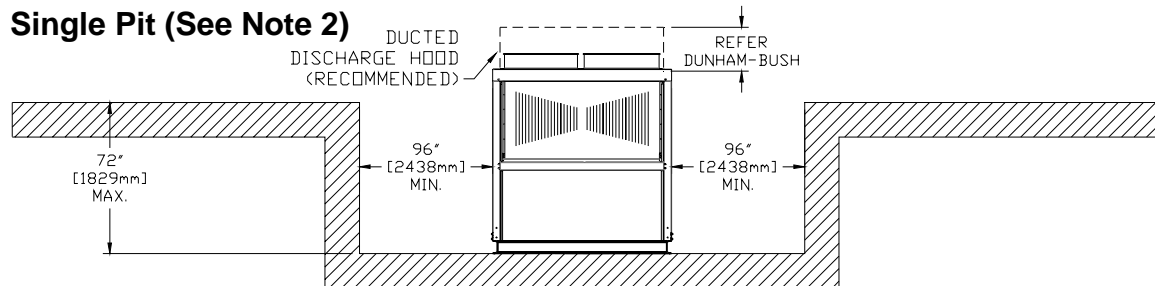

Double Pit (See Note 2)

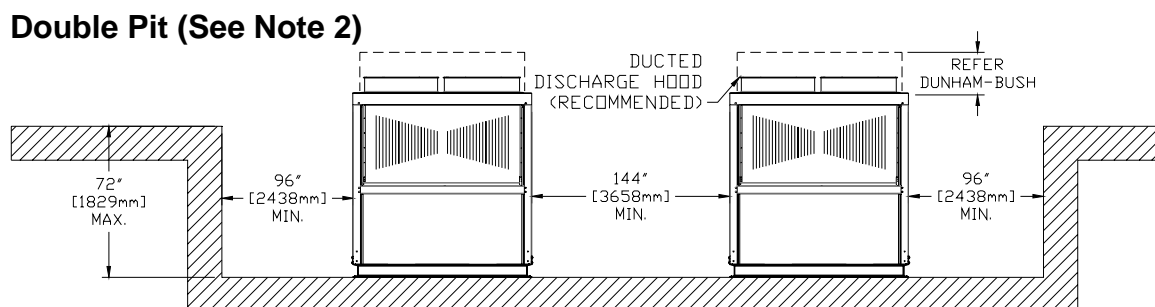

Multi Pit

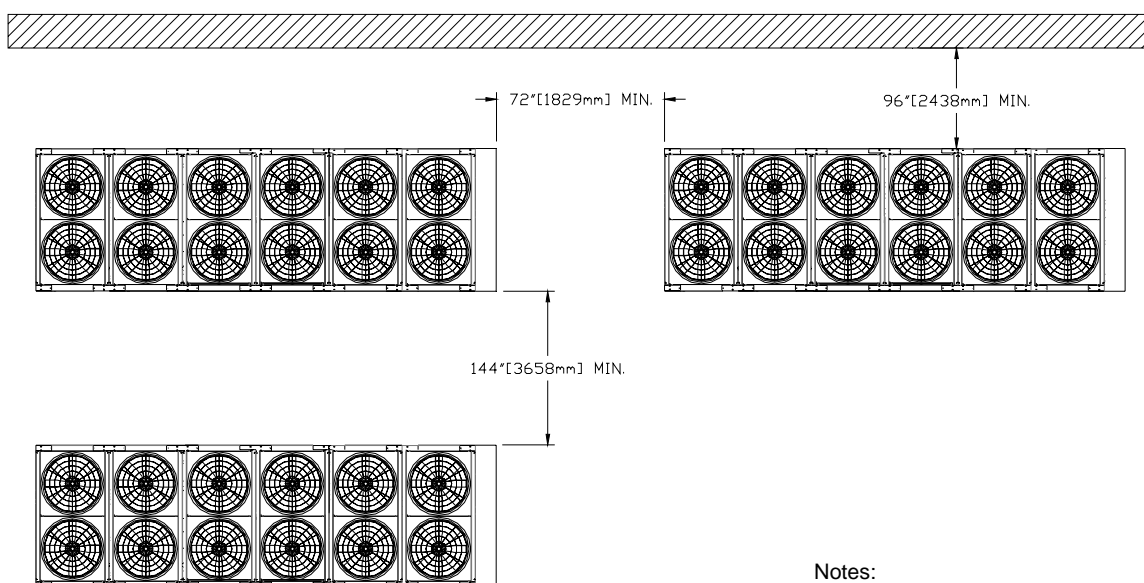

Corner Wall

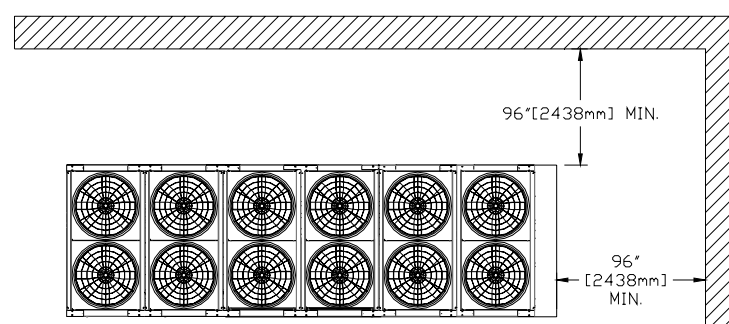

Notes:

- 1.) All dimensions are minimal, unless otherwise noted.
- 2.) Pit installations are not recommended. Re-circulation of hot condenser air in combination with surface air turbulence cannot be predicted. Hot air re-circulation will severely affect unit efficiency (EER) and can cause high pressure or fan motor temperature trips. Dunham-Bush will not be responsible for ducting fans to a higher level to alleviate the above mentioned conditions.

GUIDE SPECIFICATIONS

1.0 GENERAL

1.1 SUMMARY

Supply and commissioning of complete factory assembled air cooled screw chiller suitable for outdoor installation. The air cooled chiller shall contain rotary screw compressor(s), evaporator, air cooled condenser with coil and fan, interconnecting refrigerant piping, electronic expansion valve, control panel, chilled liquid connections. The control panel shall be fully wired by the manufacturer to connect and interlock controller, starter, protection devices with electrical power and control connections. Packaged chiller shall be factory assembled, charged and run tested with a full operating refrigerant and oil charge. The refrigerant type shall be R134a/ R513A and shall not have phasing out schedule.

Contractor shall furnish and install chiller as shown and scheduled on the drawings. Unit shall be installed in accordance with this specification.

1.2 QUALITY ASSURANCE

- ✿ Chiller performance shall be rated in accordance to AHRI 550/590 standard latest edition.
- ✿ ASME standard B31.5 for Refrigerant piping
- ✿ Vessels shall be fabricated and pressure tested in accordance with ASME Boiler and Pressure vessel code, Section VIII, Division 1 “Unfired Pressure Vessels”
- ✿ Manufacturer shall have experience of minimum 15 years in manufacturing Air Cooled Screw Chillers in their facility
- ✿ Unit shall be manufactured in ISO9001 registered manufacturing facility.
- ✿ [OPTIONAL] ASHRAE Standard 15 safety code for mechanical refrigeration
- ✿ Factory run test: Chiller shall be pressure tested, evacuated and fully charged with refrigerant and oil. The chiller shall be run tested with water flowing through the vessels.
- ✿ Manufacturer shall have a service organization with trained service personal.

1.3 DESIGN BASE

The construction drawings indicate a system based on a selected manufacturer of equipment and the design data available to the Engineer during construction document preparation. Electrical services, size, configuration and space allocations are consistent with that manufacturer’s recommendations and requirements.

Other listed or approved manufacturers are encouraged to provide equipment on this project; however, it will be the Contractor and/or Supplier’s responsibility to assure the equipment is consistent with the design base. No compensation will be approved for revisions required by the design base or other manufacturers for any different services, space, clearances, etc.

1.4 DELIVERY, STORAGE AND HANDLING

Unit shall be delivered to job site fully assembled with all interconnecting refrigerant piping and internal wiring ready for field installation and charged with refrigerant and oil by manufacturer. When delivered, machine shall be stored indoors, away from construction dirt, dust, moisture or any other hazardous material that would harm the chillers. Inspect under shipping tarps, bags, or crates to be sure there is no water collected during transit. Protective shipping covers shall be kept with the unit until machine is ready for installation.

1.5 WARRANTY

Chiller manufacturer’s warranty shall cover for 12 months from the date of start-up or 18 months from the date of shipment whichever is first. The start-up shall be carried out by an authorized service personnel and the warranty is limited to part replacement excluding labor and consumables such as refrigerant, oil & filter driers etc.

1.6 MAINTENANCE

Maintenance of the chillers will be the responsibility of the owner and performed in accordance with the manufacturer’s instructions

2.0 PRODUCTS

2.1 OPERATING REQUIREMENTS

The units will be furnished as shown on capacity schedules and drawings. Unit performance will be in accordance with AHRI Standard 550/590.

The unit shall be capable of starting up with entering fluid temperature to the cooler at 95°F [35°C].

The unit shall be capable to produce chilled fluid temperature between 40°F to 50°F [4.5°C to 10°C] at standard operating mode.

[OPTIONAL]:

A. Dual Mode operation – The unit shall capable for ice thermal storage applications with supply brine temperature down to 18°F [-7.8°C].

The unit shall be design to operate at ambient temperature 45°F to 115°F [7°C to 46°C].

[OPTIONAL]:

A. Low Ambient Operation (LA1) – The unit shall capable to operate with ambient temperature down to 14°F [-10°C].

B. Extra Low Ambient Operation (LA2) – The unit shall capable to operate with ambient temperature down to -20°F [-29°C].

Unit shall be able to operate with 3-phase power supply with voltage within +/- 10% of unit rated voltage. Control Voltage shall be 115V/1ph.

GUIDE SPECIFICATIONS

2.2 CONSTRUCTION

The unit panels, control boxes shall be constructed by heavy gauge, galvanized steel with powder coating baked finishing to pass 1000-hours salt spray test in accordance with ATSM B117 standard.

2.3 COMPRESSOR

The packaged chiller shall be furnished with Semi-hermetic rotary twin-screw compressor(s) as required, driven by a 3550 RPM (60Hz) 2 pole motor. Each compressor shall include oil sump. The oil differential pressure shall be controlled during operation to maintain proper oil lubrication throughout the lubrication system. An electric oil heater shall be provided in each compressor to maintain required oil temperature during shutdown period. The heater shall be energized when the chiller is switched off. Each compressor shall have a sight glass, suction filter, a discharge check valve and a discharge service valve. Compressor capacity control shall be obtained by an electrically initiated, hydraulically actuated slide valve within each compressor. The bearing shall be heavy duty, anti-friction, type, shall be able to carry both radial and thrust loads.

The compressor motor shall be semi-hermetic refrigerant gas cooled, 2 pole, squirrel cage induction type with class F insulation. Motor winding shall have thermistors embedded in the motor windings to protect motor from overheating. The thermistors shall be wired to the solid state motor protection module.

[OPTIONAL]:

Compressor Suction Service Valve – To further isolate compressor from evaporator.

2.4 EVAPORATOR

Evaporator vessel shall be cleanable shell and tube, flooded type. Shell shall be fabricated from rolled carbon steel sheet with fusion welded seams or carbon steel standard pipes. End plates shall be of carbon steel with precision drilling, reamed in order to accommodate tubes. Intermediate tube support shall be in place to provide required tube support between tube sheets. Tubes shall be of copper, seamless, high efficient, internally enhanced and externally finned, mechanically expanded into fixed steel tube sheets. Tube diameter shall be ¾ inch and thickness shall be 0.025 inch. The flooded evaporator shall have a built in distributor for feeding refrigerant evenly under the tube bundle to produce a uniform boiling action and baffle plates shall be provided to ensure vapor separation.

Water box shall be removable type for tube cleaning. Water connections shall be with Victaulic grooves in compliance to ANSI / AWWAC-606. Vent and drain plugs are to be provided in water box. The shell side of the evaporator shall have pressure relief valve with provision for refrigerant venting.

Evaporator refrigerant side shall be designed and constructed in accordance with the ASME Code for

Unfired Pressure Vessels. Evaporator shell side shall be designed for working pressure up to 200PSIG [13.8BAR] and undergo pneumatic pressure test at 220PSIG [15.2BAR]. Tube side shall be designed for 150PSIG [10.3BAR] working pressure and undergo hydrostatic pressure test at 195PSIG [13.4BAR].

The flooded evaporator shall have an efficient and reliable oil recovery system. The oil recovery system shall insure the evaporator is operating at peak efficiency at all times and provide optimal energy efficiency during extended periods of part load. Units without such oil recovery systems shall not be acceptable.

All low temperature surfaces shall be factory insulated with 1 inch [25mm] thick Polyethylene resin having K factor of 0.26 btu-in / hr.ft².°F.

[OPTIONAL]:

- A. Evaporator Flanged Water Connection – Flanged water connection shall be provided in lieu of Victaulic connection.
- B. Double Thick Insulation – Evaporator shall be provided with 2 inch [50mm] thick closed cell insulation for extra resistance to condensation.
- C. 250PSIG [1.7MPa] Working Pressure Vessel – Evaporator with 250PSIG working pressure on shell side shall be provided.

2.5 CONDENSER AND FANS

Condenser Coil shall be constructed with Microchannel type aluminium alloy tube brazed together with aluminium alloy fin. The whole coil shall be made of a single type material to prevent galvanic corrosion from different metals. Microchannel coil shall come anti-corrosion coating and is able to withstand more than 1400hours Sea Water Acetic Acid Test (SWAAT) in accordance with ASTM G85-A3 standard.

The coil construction shall be of V configuration in order to increase heat transfer area and condenser divider baffles shall fully separate each condenser fan section to control the air flow by fan cycling and fan staging to maintain optimum head pressure. Coil plate shall be made of galvanized steel and divider baffles shall be made of galvanized steel with powder coating.

The fan shall be direct drive propeller type, made of heavy duty alloy blades, in order to have higher resistance for dust and sand abrasion. Fan shall be protected with powder coated steel wire fan guard.

The motor shall be 3-phase, TEFC, squirrel cage induction type with IP55 enclosure and class F insulation. The motor bearing shall be permanently lubricated. Motor shall have internal thermal protection

The fan and the motor assembly shall be rigidly secured to the casing with a heavy gauge steel powder coated fan brackets with air discharge upward.

Full pump down capacity in condenser (Al-Cu option only).

GUIDE SPECIFICATIONS

[OPTIONAL]:

- A. Microchannel Condenser Coil [E-Coating] - Condenser Coil shall be constructed with Microchannel type aluminium alloy tube brazed together with aluminium alloy fin. The whole coil shall be made of a single type material to prevent galvanic corrosion from different metals. Microchannel coil shall be electro-coated with protective coating to withstand at least 3000hours Sea Water Acetic Acid Test (SWAAT) in accordance with ASTM G85-A3 standard.
- B. Aluminum Fin/ Copper Tube – The coil shall be constructed of seamless inner-grooved copper tube and die formed aluminum fins having self spacing collars in staggered configuration. Copper tubes shall be mechanically expanded into the fins.
- C. Pre-Coated Aluminum Fin/Copper Tube Coil – Copper/Pre-coated Aluminum fin construction shall be made of seamless inner grooved copper tubes mechanically expanded into pre-coated (hydrophilic coated) aluminum fins. The tube sheet shall be of galvanized steel and the divider baffles shall be of galvanized steel with powder coating.
- D. Copper Tube/ Copper Fin Coil – Copper/Copper coil construction shall be made of seamless inner grooved copper tubes mechanically expanded into copper fins. The tube sheet shall be of galvanized steel or stainless steel and the divider baffles shall be of galvanized steel with powder coating.
- E. Post-Coated Aluminum Fin Coil – Copper tube/per-coated Aluminum fin coil construction shall be made of seamless inner grooved copper tubes mechanically expanded into Aluminum fins. The tube sheet shall be of galvanized steel. The entire fin shall be coated with anti corrosive coating after the coil fabrication. The divider baffles shall be made of galvanized steel with powder coating.
- F. Protective Grille for Condenser Coil – Protective grille shall be provided to condenser coil section to prevent unauthorized access.

2.6 REFRIGERANT CIRCUIT

The refrigerant circuit shall include discharge service valves, liquid line shut off valve, oil filter, replaceable filter drier, and sight glass at liquid line. Liquid line angle valve shall be provided for refrigerant charging. Pressure relief valves shall be provided at evaporator and compressor body.

The packaged chiller shall be furnished with electronic expansion valve for precise modulation of refrigerant flow control and improve efficiency by optimizing the suction and discharge superheat. In addition, the refrigerant control system shall optimized refrigerant liquid level in the flooded evaporator to protect the compressor from slugging liquid refrigerant. Fixed orifice control systems shall not be acceptable.

[OPTIONAL]:

- A. Heat Recovery – Factory supplied shell-and-tube heat exchanger to reclaim waste heat from the system to produce hot water up to 131°F [55°C].
- B. Hotgas Bypass – Shall be factory for operation down to approximately 10% of full load.

2.7 OIL MANAGEMENT

The chiller package shall ensure proper lubrication during the operation in order to have prolonged compressor life as well as maintaining system efficiency. An efficient pressure differential lubrication system shall be provided with oil filter, sight glass, oil sump and oil sump heater. The oil heater shall be energized during the chiller switched off to prevent oil from dilution. Oil pump shall not be acceptable.

2.8 ELECTRICAL AND CONTROL PANEL

The electrical switch gears, controller, sensor transmitters and relays shall be housed in IP54 panel. The panel casing shall be of galvanized steel with powder coating baked finishing for corrosion resistance. The panel shall be divided into two separate compartments or shall have two separate panels to house power and control devices separately.

The chiller manufacturer shall provide suitable reduced inrush starter for the compressor motor in order to minimize the starting current. The starter shall be factory mounted, wired to the motor and controller. The starter shall be able to provide adequate starting torque and the required acceleration for the compressor during starting.

The electrical panel compartment shall include:

- A. Main incoming power terminal block suitable to receive single entry of three phase 3-wire power supply with specified voltage.
- B. Circuit breaker for each compressor.
- C. Solid state / thermal compressor motor with over current protection module for each phase.
- D. Solid state compressor motor overheat protection module.
- E. Under/over voltage phase reversal and imbalance relay.

The compressor starter contactors and circuit breakers shall be wired securely to the main incoming terminal block. Solid state/ thermal external compressor over load protector, over heating protection modules, over/under voltage phase relay shall be interlocked with the compressor starter contactors to provide adequate protection to the compressor motor.

[OPTIONAL]:

- A. IP55 control panel – Option shall be offered to upgrade the standard IP54 control panel to IP55 rated.
- B. Unit Mounted Main Disconnect Switch – Non-fused disconnect switch with external lockable handle shall be provided to isolate unit main incoming power supply for servicing.
- C. Ground Fault Interrupt (GFI) – GFI shall be provided for ground fault protection of the unit.
- D. Softstarter for compressors motor – Solid state starter comes with bypass contactor shall be offered in lieu of standard starter for better compressor starting characteristic.

GUIDE SPECIFICATIONS

E. Ammeter/ Voltmeter – Analog ammeter and voltmeter with 3-phase selector switch shall be provided for quick system voltage and current indication.

2.9 CONTROLS

2.9.1 GENERAL

The packaged chiller shall be equipped with stand along proactive advance controller which adapts to abnormal operation conditions. The unit algorithm program and operating parameters shall be stored in flash-memory that does not require a battery back-up. Controller requires back-up battery is not acceptable.

115V power supply to the control circuit shall be provided by a factory mounted control transformer installed in the panel. External power source to the control circuit is not acceptable.

The controller shall be equipped with a user friendly back-lit 132 x 64 pixels semi-graphic display and dedicated keys that provide easy access to the unit operating parameters, control set points and alarm history. There shall be dedicated physical buttons to enable user to access information, based on security level of password. There shall be min three level of password for operator, service personnel and for the critical manufacturer settings in order to protect the chiller controller from unauthorized access.

The controller shall be provided with a set of terminals that connected to various devices such as temperature sensors, pressure transducers, current transducers, solenoid valves, compressor contactors, electronic expansion valve, control relays. The controller should be able to be configured and connected multiple units that allow sequencing control without additional hardware. The controller shall be able to carry out all program operations. It shall be able to display unit operating parameters, compressor information, alarm history and shall able to modify the parameters.

The controller shall be able to carry out self-diagnostic test on the controller and the connected devices and alarm messages shall be displayed automatically on faulty devices.

All messages shall be displayed in English language. Readings and settings displayed shall be selectable between Imperial or SI units.

Leaving chilled water temperature control shall be accomplished by entering the water temperature set point with accuracy to 0.8°F and placing the controller automatic control mode. The controller shall monitor all control functions and move the compressor slide valve to the calibrated position. The compressor loading cycle shall be programmable and shall be adjusted to the building load requirement. The loading adjustable range shall be from 0.1% to 0.4% per increment to prevent excessive demand hike at start up.

The controller shall continuously monitor evaporator leaving water temperature, rate of change of chilled

water leaving temperature, evaporator and condenser pressure; compressor amp draw; and discharge refrigerant temperature.

The controller shall be capable to accept low level remote control signal. Remote Start/Stop shall be provided as standard for unit start/stop by external on/off signal.

[OPTIONAL]:

Chilled Water Temperature Reset – The controller shall be capable to accept a 0 to 5VDC chilled water temperature reset signal to reset the chilled water supply temperature setpoint, based on external demand.

Demand Limit / Current Limit – The controller shall be capable to accept a 0 to 5VDC demand limit signal to limit the compressors operating current during the unit operation.

The electrical control panel shall be wired to permit fully automatic operation during - initial start-up, normal operation, and shutdown conditions. The control system shall contain the following control, displays and safety devices:

2.9.2 AUTOMATIC CONTROLS

- ✿ Compressor motor increment contactors
- ✿ Start delay timer
- ✿ Anti-recycle timer
- ✿ Oil sump heater interlock relays

2.9.3 MANUAL CONTROLS

- ✿ Auto/Local/Remote switch
- ✿ Control circuit stop and start switches
- ✿ Compressor enable switch
- ✿ Compressor over current
- ✿ Programmable with Seven day operation cycle

[OPTIONAL]:

Dual mode changeover switch – Digital input to changeover unit operation from chiller mode to freezing mode.

2.9.4 INDICATOR LIGHTS

- ✿ Control power
- ✿ Compressor run
- ✿ Compressor motor overload
- ✿ System common alarm

The control system shall be provided with an anti-recycle device. The control shall limit compressor starting to a minimum of 15 minutes between starts.

2.9.5 REFRIGERANT CONTROLS

- ✿ Refrigerant flow control shall be carried out electronically by a precision electronic expansion valve
- ✿ Compressor loading and unloading solenoid valves

GUIDE SPECIFICATIONS

2.9.6 SYSTEM INFORMATION

The chiller display shall provide following operating information.

- ✿ Leaving chilled water temperature
- ✿ Entering Chilled water temperature
- ✿ Compressor discharge temperature
- ✿ Leaving chilled water temperature derivative
- ✿ Evaporator pressure
- ✿ Condenser pressure
- ✿ Ambient Temperature
- ✿ Compressor amps draw for each compressor
- ✿ Compressor elapsed run time of each compressor
- ✿ Compressor start status
- ✿ Oil level sensor status
- ✿ Water flow switch status
- ✿ External start/stop command status
- ✿ Percentage of compressor capacity
- ✿ Electronic expansion valve percentage of opening

[OPTIONAL]:

- ✿ Operating supply Voltage
- ✿ Chilled water temperature reset value
- ✿ Demand limiting value

2.9.7 SAFETY PROTECTION

- ✿ Short circuit protection
- ✿ Compressor motor over load protection (3 phase)
- ✿ Compressor over current
- ✿ Compressor motor overheat protection
- ✿ Compressor Anti-recycle
- ✿ High discharge temperature protection
- ✿ Under voltage phase failure relay
- ✿ Low oil level protection
- ✿ High condenser pressure
- ✿ Low evaporator pressure
- ✿ Freeze protection (low chilled liquid leaving temperature)
- ✿ Chilled water flow loss
- ✿ Low differential pressure
- ✿ Power loss
- ✿ Sensor error
- ✿ Refrigerant loss (by low pressure)
- ✿ Reverse rotation

Controller shall be able to retain up to 99 alarm conditions complete with time of failure and all critical sensor readings. This aids service technicians in their trouble shooting task enabling downtime and nuisance trip-outs to be minimized.

2.9.8 REMOTE MONITORING (BMS INTERFACING)

The controller shall be designed to make easy on BMS interfacing by just an optional add-on communication card.

Various communication protocols as below shall be offered for user's selection.

- ✿ Modbus RTU RS485 / TCPIP
- ✿ BACnet TCPIP / MStP / PTP
- ✿ LONworks

2.9.9 OPTIONAL ACCESSORIES

Factory shall supply below accessories for customer's field installation.

- ✿ Evaporator Water Flow Switch – Weather tight flow switch with three options for customer's selection; Flow switch with CE mark; NEMA 1 and NEMA 4 rated flow switch
- ✿ Rubber-In-Shear Isolators
- ✿ Spring Isolators

3.0 EXECUTION

3.1 INSTALLATION

Chiller shall be installed strictly according to manufacturer's recommendations as stipulated in the installation manual, drawings and tender documents. Care should be taken to provide necessary service clearance as required in the manufacturer's drawing. Install the strainers at the inlet to the evaporator to prevent debris or other particles entering to the evaporator during piping work and initial flushing the system. Required coordination to be done with the electrical contractor and the control contractors to ensure electrical supply and required communications links are established.

3.2 START-UP/COMMISSIONING

Chiller shall be commissioned by a service representative from manufacturer or by their local representative. The service personnel shall be trained and authorized by the manufacturer for start up of the supplied units. The start-up shall include briefing operators on chiller operations and maintenance as well.



Malaysia

Lot 5755-6,
Kidamai Industrial Park,
Bukit Angkat,
43000 Kajang,
Selangor, Malaysia

Tel: +603-8924 9000
Fax: +603-8739 5020

China

No. 1 Dunham-Bush Road,
Laishan District,
Yantai,
Shandong Province,
China 264003

Tel: +86-535-739 7888
Fax: +86-535-739 7999

United Kingdom

8 Downley Road,
Havant,
Hampshire,
England PO9 2JD

Tel : +44-23-9247 7700
Fax: +44-23-9245 0396

United States of America

1800 SE 38th Avenue,
Homestead,
Florida 33035
United States of America

Tel: +1(786)-800 9999
Fax: +1(786)-527 3539

United Arab Emirates

Office # 2606,
Fortune Executive Towers,
Cluster T1, Jumeirah Lake Tower
Dubai, UAE

Tel: +971-4-443 9207
Fax: +971-4-443 9208

South Africa

No. 57 Sovereign Drive
Route 21 Corporate Park
Irene, Pretoria
South Africa

Tel: +27-12-345 4202
Fax: +27-12-345 4203

India

Unit no : 804 , 8th Floor
Spaze Platinum Towers,
Sector-47, Sohna Road,
Gurgaon-122018, India

Tel: +91-124-414 4430

Indonesia

The Boulevard Office,
3F2 Jl. Fachrudin No.5,
Kp. Bali, Tanah Abang
Jakarta Pusat - 10250, Indonesia

Tel: +62-21-2123 1392

Thailand

48/39 Soi Praditmanutham 19
Praditmanutham Road,
Lat Pharo, Bangkok 10230
Thailand

Tel: +66-0-2610 3749
Fax: +66-0-2610 3601

Singapore

2 Kallang Pudding Road
#07-07 Mactech Building
Singapore 349307

Tel: +65-6842 2012
Fax: +65-6842 2013

Vietnam

10th Floor, Nam A Bank Tower,
201-203 Cach Mang Thang 8 Street,
District 3, Ho Chi Minh City,
Vietnam

Tel: +84-8-6290 3108
Fax: +84-8-6290 3109

DUNHAM-BUSH®

info@dunham-bush.com
www.dunham-bush.com



Products that perform...By people who care

Manufacturer reserves the right to change specifications without prior notice.

M-S-04113A-1021