



Helios

Air Cooled Screw Chillers

ACHX-B 50Hz

Cooling Capacity: 90 to 395 TR (317 to 1389 kW)



DUNHAM-BUSH®

Products that perform...By people who care

INTRODUCTION

For more than 100 years, Dunham-Bush has focused on innovative product development. Today, we provide a full portfolio of HVAC/R products from Fan Coil Units to large centrifugal chillers as well as many other innovative green solutions. Our commitment to innovation, matched with an aggressive attitude toward growth, makes Dunham-Bush a leader in global markets. Our product development is tailored to meet the specific needs of customers. No other HVAC/R manufacturer takes this approach to meeting your performance expectations.

HELIOS, ACHX-B Air Cooled Screw Flooded Chillers, have a cooling capacity range from 90 to 395 TR [317 to 1389 kW] in 50Hz version using environmentally friendly HFC-134a refrigerant. The entire product line features energy efficiency, installation ease, control flexibility, high reliability and advanced Vision controller. The ACHX-B series are certified to AHRI Standard 550/590 and meets ASHRAE Standard 90.1-2016.

TABLE OF CONTENT

	Page No		Page No
Introduction	2	Sound Pressure Data	14
Nomenclature.....	2	Dimensional Data.....	15
General Characteristics	3	Floor Loading Diagram.....	21
Unit Features	3	Field Power & Control Wiring Schematic.....	22
Options & Accessories.....	6	Application Data	23
Operating Benefits	8	Minimum Clearance Requirements	26
Physical Specifications	10	Guide Specifications.....	27
Electrical Data.....	14		

NOMENCLATURE

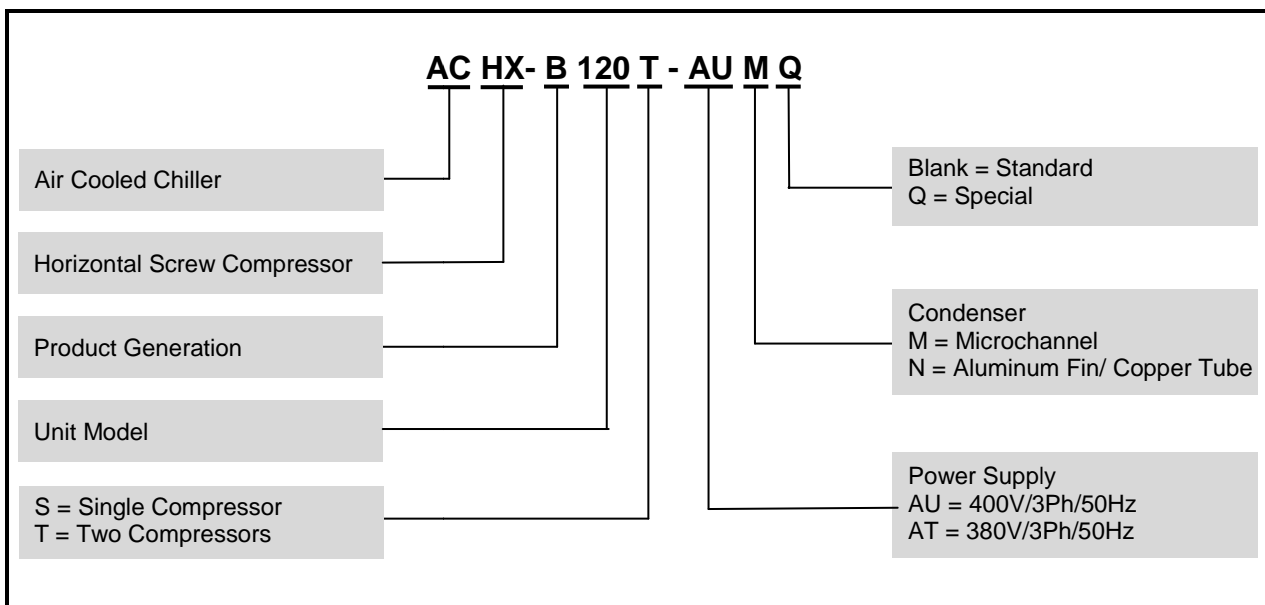

GENERAL CHARACTERISTICS

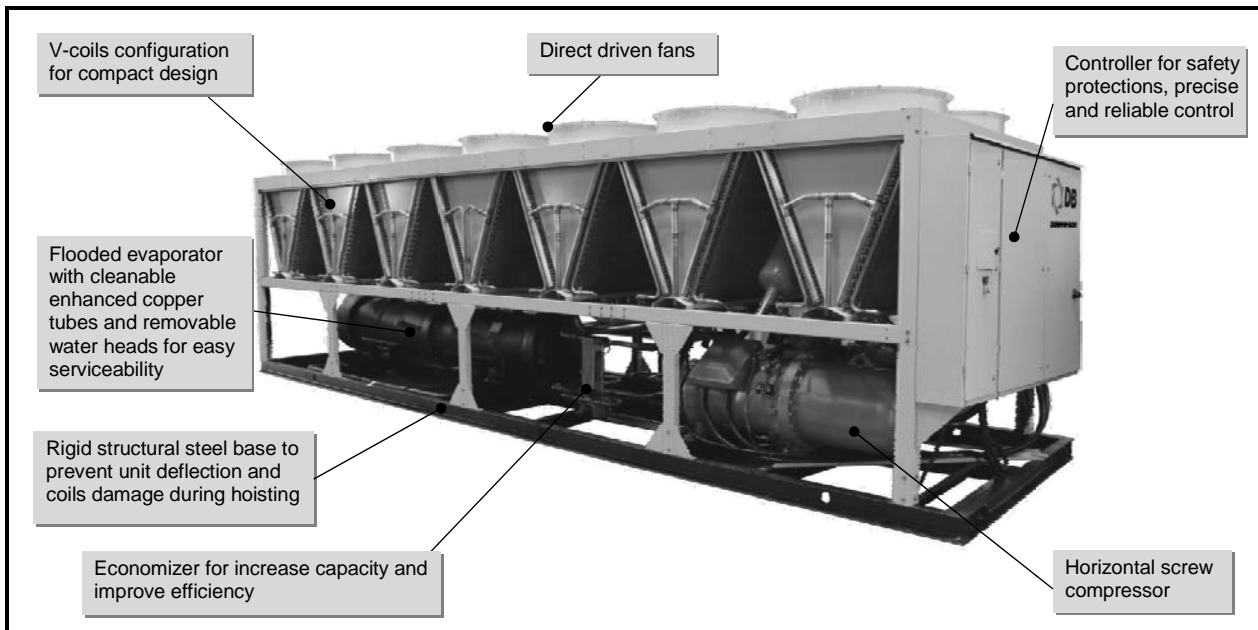

UNIT FEATURES

General

- ✦ 16 models from 90 to 395 TR [317 to 1389 kW] in accordance with AHRI standard conditions
- ✦ Multiple compressors models with independent refrigerant system per compressor provide redundancy, and superior part load efficiency
- ✦ The unit is designed to operate with R134a, the environment friendly refrigerant with zero **ODP** (Ozone Depletion Potential)
- ✦ Unit operating ambient temperature, 45~115°F [7~46°C]

Compressor

- ✦ Semi-hermetic Horizontal Screw Compressor
- ✦ Suction gas-cooled compressor motor
- ✦ Multiple rotary screw compressors design for better reliability and redundancy
- ✦ External oil pump not required
- ✦ Optimized oil management
- ✦ Integrated sensor in each motor winding for thermal motor temperature monitoring
- ✦ Infinite variable capacity control with sliding valve mechanism

Evaporator

- ✦ Shell-and-tube flooded type heat exchanger
- ✦ Two pass arrangement
- ✦ Integral finned copper tubes to maximize heat transfer area
- ✦ Cleanable copper tubes for easy serviceability
- ✦ Removable water heads for service
- ✦ Victaulic groove water connection comply to ANSI/AWWA C-606
- ✦ Standard with 1" thick closed cell insulation
- ✦ Standard relief valve(s) – 3/4" [19mm] FPT
- ✦ Pressure test up to 220psig for refrigerant side, and 195psig for water side
- ✦ Isolation valves for refrigerant filter dryers are provided to allow filter core replacement without pump down the chiller. This greatly improves the servicing expenses and time

Condenser and Fans

- ✦ Microchannel condenser coil consists of all aluminum coils with multiple flat tubes containing small channels (Microchannels) metallurgically brazed with louvered fin.
- ✦ All Microchannel coils come with TCP-Coating which provides an anti-corrosion protective layer for the coil
- ✦ "V" coil design to increase condensing surface area to maximize heat rejection
- ✦ "V" coils arrangement with internal baffle for fan cycling and staging
- ✦ IP55, Class "F" insulation fan motors for outdoor applications

UNIT FEATURES

Electronic Expansion Valve

- ✿ Advanced electronic expansion valve (EEV) is used for precise control of liquid refrigerant flow into the evaporator
- ✿ Evaporation of liquid refrigerant in evaporator is controlled at precise level for optimum performance

Economizer

- ✿ The economizer circuit consists of plate type heat exchanger, expansion valve and solenoid valve
- ✿ Refrigerant is sub-cooled at economizer before entering the evaporator
- ✿ The economizer increased cooling capacity by means of increasing the sub-cooling
- ✿ Cooling capacity is increased significantly with marginal increases in kW-input, thus, unit EER is improved

Control Panel

- ✿ Weather tight electrical enclosure fabricated by heavy gauge sheet steel with powder coated baked finishing
- ✿ Single point power connection for all models
- ✿ Unit mounted reduced inrush starter for compressor motors
- ✿ Circuit breaker for compressors and condenser fan motors
- ✿ Step down transformer for power supply to control circuit
- ✿ Main power supply monitoring module. Protection on under or over voltage, phase reversal, phase losses and imbalance
- ✿ Unit mounted Remote/Off/Local (R/O/L) selector, an operation and servicing friendly feature
- ✿ Overload protection relay for compressors
- ✿ Vision controller – the state-of-art Dunham-Bush proactive advanced controller that adapts to any abnormal operating conditions and for safety protections
- ✿ Chilled water pump control

VISION CONTROLLER

Vision controller a flexible and advance programmable microprocessor controller designed specifically for the application and precise control of Dunham-Bush Rotary Screw compressor chillers.

The controller is provided with a set of terminals that connect to various devices such as temperature sensors, pressure and current transducers, solenoid valves, compressors and fans starters, control relays, etc. Three sizes of controller boards are provided to handle different number of input and output requirements: DB5-S small, DB5-M medium and DB5-L large board.

The unit algorithm program and operating parameters are stored in FLASH-MEMORY that does not require a back-up battery. The program can be loaded through PC or programming key.

Vision controller is equipped with a user friendly terminal with a semi-graphic display and dedicated keys that provides easy access to the unit operating conditions, control set points and alarm histories.

Each unit's controller can be configured and connected to the Dunham-Bush DBLAN network that allows multiple chillers sequencing control without additional controller or panel. Dunham-Bush DBLAN is the local area network made up of several chillers' controller.



Display and User Terminal

The Vision controller is designed to work with a user friendly back-lit 132 by 64 pixels PGDE Semi-Graphic Display panel connected with the controller through a telephone cable. The terminal display allows carrying out of the unit operations, and also allows the unit working conditions, compressor run times and alarm history to be displayed. Set points and other parameters can be modified via the user terminal. The display has an automatic self-test of the controller on system start-up. Multiple messages will be displayed automatically by scrolling from each message to the next. All of these messages are spelled out in English on the display terminal.

Easily accessible measurements include:

- ✿ Leaving and entering chilled water temperature
- ✿ Rate of Change for leaving chilled water temperature
- ✿ Evaporator and condenser pressure
- ✿ Compressor discharge temperature and superheat
- ✿ Ambient temperature
- ✿ Current drawn by each compressor
- ✿ Compressor capacity (percentage of FLA, Full Load Amps)
- ✿ Run hours of each compressor
- ✿ Number of starts of each compressor
- ✿ Electronic Expansion Valve (EEV) Opening Percentage
- ✿ Compressors and condenser fans motors status
- ✿ Oil Level Status, Water Flow Switch Status, Remote Start/Stop Command Status

UNIT FEATURES

Capacity Control

Leaving chilled water temperature control is accomplished by entering the water temperature setpoint and placing the controller in automatic control. Vision controller monitors all control functions and moves the compressors slide valve to the required position to match the building cooling load demand.

The compressor ramp (loading) cycle is programmable and may be set for specific building requirements. Remote adjustment of the leaving chilled water setpoint is accomplished either through High Level Interfacing (HLI) via BMS communication, or Low Level Interfacing (LLI) via an external hardwired, 4 to 20mA chilled water reset control signal. Remote reset of compressor current limiting function can be accomplished in a similar fashion.

System Control

The unit may be started or stopped manually, or through the use of an external signal from a Building Automation System. In addition, the controller may be programmed with seven-day operating cycle or other Dunham-Bush control packages may start and stop the system through inter-connecting wiring.

System Protection

The following system protection controls will automatically act to ensure system reliability:

- ✱ Low evaporator pressure
- ✱ High condenser pressure
- ✱ Freeze protection
- ✱ Low suction-discharge pressure differential
- ✱ Low compressor oil level
- ✱ Compressor run error
- ✱ Power loss
- ✱ Chilled water flow loss
- ✱ Sensor error
- ✱ Compressor over current
- ✱ Compressor Anti-recycle
- ✱ High motor temperature
- ✱ Compressor overload

The controller can retain up to 99 alarm histories complete with time of failure together with data stamping on critical sensor readings in an alarm condition. This tool will aid service technicians in troubleshooting tasks enabling downtime and nuisance trip-outs to be minimized.

Remote Monitoring And Control (Option)

Dunham-Bush, the leader of HVAC solution provider understands the arising focus on chiller plant performance and optimization. Several solutions as below are offered to the building owner to achieved optimized chiller plant room controls, operation and performance.

Dunham-Bush Chiller Plant Manager (CPM)

DB Chiller Plant Manager (**CPM**) is a trustworthy and headache-free solution for building owners and users on chiller plant control and automation system. **CPM**'s advanced controllers monitor and control equipments in chiller plant such as chillers, primary and secondary chilled water pumps, variable frequency drives (VFD), motorized valves, bypass modulating valves, and etc. Field devices such as flow meters, BTU meters, digital power meters, sensors & transducers can be interfaced with **CPM** via HLI or LLI. CPM controls chillers and pumps sequencing, as well as lead-lag, duty-standby and alarm changeover operations.

NetVisorPRO – Monitoring software of **CPM** system which allows system monitoring, historical trending, and alarm logging to be carry out at a PC terminal. Graphical animations on system operation, temperature and flow rate trend graphs, historical data and alarm history logs, settings changes are all available with **NetVisorPRO**.

Chiller plantroom control and automation by Dunham-Bush **CPM** provides the owners with a chiller system in stable operation, optimized performance and energy efficiency.

DB-LAN Master Slave Sequencing Control (MSS)

In a chiller system with multiple Dunham-Bush chillers, Vision controller of each chiller can be connected to the DB-LAN network via a communication bus without additional controller, to enable Master-Slave Sequencing Control of this chiller system. **MSS** will stage in/out chiller in operation to match building required cooling capacity. Chiller Lead-lag, duty-standby and alarm changeover controls are come with **MSS**, as well as the chilled water pumps control. Each **MSS** DB-LAN network can be connected up to 8 numbers of chillers.

Building Management System (BMS) Communication

Vision controller is able to communicate to BMS through the add-on communication card via various common protocols as:

- ✱ Modbus RTU RS485, ModBus TCP/IP
- ✱ BACnet over IP, MS/TP, or PTP
- ✱ LONworks FTT10

OPTIONS AND ACCESSORIES

- ✿ **Microchannel Condenser Enhanced Corrosion Protection** – Optional E-Coating which provides an enhanced anti-corrosion protective layer for microchannel coil for harsh environment
- ✿ **Fin and Tube Condenser** – Coil constructed of seamless inner grooved copper tubes expanded into die-formed aluminium slit fins
- ✿ **Fin and Tube Condenser Corrosion Protection** – Copper (CU) fin or coated fin for fin and tube coil are provided to give better corrosion protection.
- ✿ **Heat Recovery** – The hot gas desuperheater; a shell-and-tube heat exchanger that reclaims ‘waste’ heat from compressor to produce hot water up to 55°C
- ✿ **Service Valve** – Compressor Discharge service valve and suction service valve are supplied to further isolate the compressor from evaporator
- ✿ **Hotgas Bypass** – To maintain unit operation below minimum unloaded capacity
- ✿ **Low Ambient Operation (LA 1)** – Variable frequency drive (VFD) is incorporated to the condenser fan motor to allow unit operation down to 14 °F [-10 °C] ambient temperature
- ✿ **Extra Low Ambient Operation (LA 2)** – Add-on low ambient kit to allow unit operation down to -20°F [-29°C] ambient temperature
Note: Please consult factory for this option
- ✿ **Double Thick Insulation** – Evaporator with double thick 2” [50mm] closed cell insulation, for extra resistance to condensation
- ✿ **Evaporator Anti-Freeze Protection** – When chiller is not operating at ambient temperature 32°F [0°C] or below, the immersion heater and circulating pump will be in operation to prevent water freezing in evaporator (**Some of the model unit dimension may change for this option**)
- ✿ **250psig Working Pressure Vessel** – Evaporator with 250psig working pressure on water side
- ✿ **Condenser Coil Guard** – To protect condenser coil from unauthorized access
- ✿ **Evaporator Flanged Water Connection** – Flanged water connection is available as option
- ✿ **Dual Mode Operation** – The unit with dual mode operation can deliver chilled fluid temperature down to 18°F [-7.8°C] during ice making mode. Units with Dual Mode Operation is used for Ice Thermal Storage System
- ✿ **Low Temp. Operation** – The unit with Low Temp. Operation can deliver chilled fluid temperature down to 18°F [-7.8°C] for process cooling application
- ✿ **ASME/ PED Compliance** – Evaporator with ASME/ PED approval is available

- ✿ **Thermal Dispersion Flow Switch** – Optional thermal dispersion flow switch (TDFS) can be installed at the evaporator leaving fluid connector. The TDFS function is to provide evaporator fluid flow indication for chiller startup.
- ✿ **BMS Communication** – Various add-on communication cards provide BMS communication via common protocols: Modbus RTU RS485 / TCP/IP, LONworks FTT10, BACnet over IP / MSTP / PTP
- ✿ **CE Compliance** – Unit with CE compliance is available on request

Electrical And Controls

- ✿ **Unit Mounted Main Disconnect Switch** – Non-fused disconnect switch with external lockable handle is furnished to isolate unit main incoming power supply for servicing
- ✿ **Softstarter For Compressor Motors** – Solid State starter comes with bypass contactor to reduced mechanical stress and inrush current at compressor start-up
- ✿ **Ground Fault Interrupt (GFI)** – Provides equipment with ground fault protection
- ✿ **Ammeter/ Voltmeter** – Analog ammeter and voltmeter with 3 phase selector switch for indication, located inside the control panel
- ✿ **Chilled Water Reset/ Demand Limiting** – Low level interfacing with Building Automation System (BAS). Chilled Water Reset allows controlled temperature setpoint to be reset by a 4-20mA signal from BAS; while Demand Limiting will limit the maximum current drawn by the compressors by 4-20mA signal from BAS
- ✿ **Ambient Temperature Monitoring** – Temperature sensor to monitor unit operating ambient temperature
- ✿ **System Voltage Measurement** – System voltage option is a safety features to protect system from high and low voltage due to unbalance power supply. The controller will trigger alarm high or low voltage and cut-off running system
- ✿ **IP55 Control Panel** – IP55 rated control panel can be supplied for harsh working environment
- ✿ **Vision Controller Touch Screen** – 7” touch screen for display and user configuration
- ✿ **BMS Communication** – Various add-on communication cards provide BMS communication via common protocols: Modbus RTU RS485 / TCP/IP, LONworks FTT10, BACnet over IP / MSTP / PTP

OPTIONS AND ACCESSORIES

Factory Supplied, Field Installed By The Customer

- ✿ **Evaporator Water Flow Switch**– Flow switch to be installed at evaporator and condenser outlet piping as safety interlock to evaporator and condenser water flow status. Three options are available: Weather tight flow switch with CE mark; NEMA 1, and NEMA 4 rated flow switch
- ✿ **Rubber-In-Shear Isolators** – Designed for ease of installation. These one-piece molded rubber isolators are applicable for most installations
- ✿ **Spring Isolators** – These housed spring assemblies have a neoprene friction pad at the bottom to prevent the passage of noise, and a spring locking levering bolt at the top. Neoprene inserts prevent contact between the steel upper and lower housings. Suitable for more critical application as compared to rubber-in-shear isolator
- ✿ **DB-LAN Master Slave Sequencing Control (MSS)**
 - Pre-programmed at factory; field supplied and installed inter-connection wiring between chillers to provide communication bus among chillers' controllers to enable Master-Slave Sequencing Control
- ✿ **Chiller Plant Manager (CPM)** – Factory supplied control panel; field supplied and installed interconnection wiring and field devices; for complete chiller plantroom automation

OPERATING BENEFITS

EFFICIENCY AND RELIABILITY

Energy Efficiency

- ✦ Designed to provide the greatest amount of cooling for the least power input over the entire operating range of your building
- ✦ Delivers outstanding efficiency and total energy savings through the utilization of economizer cycle and advanced controller staging; to produce greater capacity with fewer compressors
- ✦ Maximized performance through computer-matched components and multiple compressors
- ✦ High efficiency oil recovery system guarantees removal of oil carried over in the refrigerant and maintains the heat exchangers at their maximum efficiency at both full and part load

Refrigerant Compatibility

- ✦ Designed to operate with environmentally sound and economically smart HFC-134a with proven efficiency and reliability
- ✦ Consult Factory for use of other HFC refrigerants.

Flooded Evaporator

- ✦ Flooded evaporator design that fully utilized and maximized the heat transfer area available in the evaporator; operates with lower suction superheat, smaller evaporator approach. These have greatly improved efficiency of chiller with flooded evaporator
- ✦ Flooded evaporator water heads can be removed easily without dismantling the chilled water piping connections, for inspection and for mechanical tubes cleaning with brushes or auto-brush. This will enable low tube fouling factor in the evaporator to be ensured, thus maintaining system efficiency

Operational Advantages

- ✦ Dramatic payback in reduced maintenance and overhaul costs both in downtime and in labor expenditures
- ✦ Ease of troubleshooting through controller retention of monitored functions

Factory Testing

- ✦ Each chiller undergoes the factory testing prior to unit shipment. This assures consistencies of workmanship at highest quality
- ✦ Thus, all units shipped are completely factory tested; charged and adjusted according to the design parameters, for ease of installation and minimal field start-up adjustments

Control Flexibility

- ✦ Controller-based with DDC controller (direct digital control) features precise push button control over every aspect of operation with built-in standard features that maximized energy savings on start-up and throughout the life of your equipment
- ✦ Ensured uniform compressor loading and optimal energy efficiency through controller to controls which utilize pressure transducers to measure evaporator and condenser pressure
- ✦ Lower energy costs resulting from automatic load monitoring and increased accuracy and efficiency in compressor staging
- ✦ Various communication options for remote monitoring of the unit operation
- ✦ Proactive control anticipates problems and takes corrective action before they occur. Controls will unload compressor(s) if head or suction pressure approach limits. This will enable unit to stay on line while warning operator of potential problems
- ✦ Stable and efficient operation with precise chilled water temperature control. Chilled water temperature is controlled at ± 0.8 °F [0.5 °C] range for your comfort cooling, with best energy saving

REFRIGERATION CYCLE

Dunham-Bush rotary screw air cooled chillers are designed for efficiency and reliability. The rotary screw compressor is a positive displacement, variable capacity compressor that will allow operation over a wide variety of conditions.

The refrigerant management system is shown in the refrigerant cycle diagram.

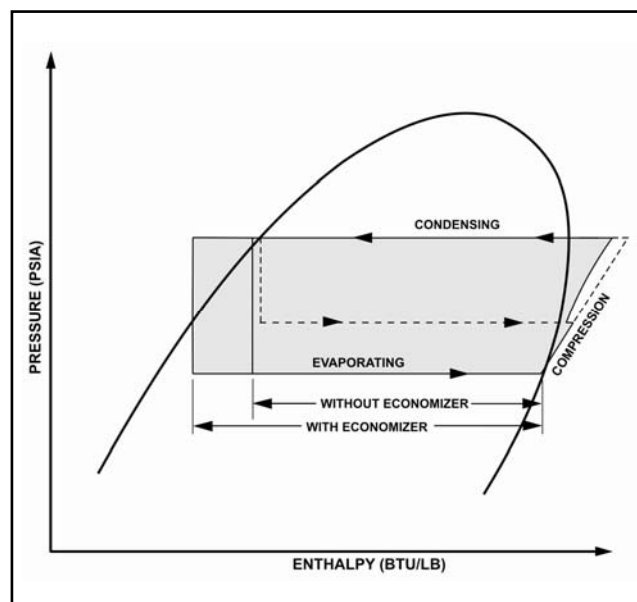

OPERATING BENEFITS

Liquid refrigerant enters the flooded evaporator uniformly where it absorbs heat from water flowing through the evaporator tubes. The vaporized refrigerant is then drawn into the suction port of the compressor where the positive displacement compression begins.

This partially compressed gas is then combined with additional gas from the vapor injection port at an intermediate pressure. Compressed gaseous refrigerant is then discharged into the integral oil separator where oil, which is contained in the refrigerant vapor, is removed and returned to the oil sump.

Fully compressed and superheated refrigerant is then discharged into the condenser, where air is being drawn through the condenser tube by the propeller fan cools and condenses the refrigerant. The liquid refrigerant then passes through the economizer. A portion of liquid refrigerant is tapped passes through the expansion valve back into the economizer for further subcooling of main liquid refrigerant flow.

The gaseous refrigerant is then drawn out of the economizer and into the vapor injection port of the compressor. The remaining subcooled liquid refrigerant then passes through electronic expansion valve which reduces refrigerant pressure to evaporator levels where it is then distributed evenly into the evaporator.

With the additional subcooling, the enthalpy of the refrigerant flowing into the evaporator is reduced which increases the refrigeration effect and improves the efficiency of the refrigeration cycle.

Economizer/ Vapor Injection Cycle for Increase Capacity and Higher EER

The renowned Dunham-Bush screw compressor allows for economizer vapor injection cycle to be incorporated, increasing capacity by significantly with marginal increase in kW-input. Thus, unit EER is improved!

PART-LOAD PERFORMANCE

Through the use of economizer, electronic expansion valve and multiple compressors, Dunham-Bush air cooled chillers have some of the best part-load performance characteristics in the industry when measured in accordance with AHRI Standard 550/590.

In most cases, actual building system loads are significantly less than full load design conditions, therefore chillers operate at part load most of the time.

Dunham-Bush air cooled chillers combine the efficient operation of compressors with economizer cycle and advanced controller to yield the best total energy efficiency and significant operating saving under any load.

When specifying air conditioning equipment, it is important to consider the system load characteristics for the building application. In a typical city, the air conditioning load will vary according to changes in the ambient temperature. Weather data compiled over many years will predict the number of hours that equipment will operate at various load percentages.

The Air Conditioning and Refrigeration Institute (AHRI) has established a system, in AHRI Standard 550/590, for measuring total chiller performance over full and part-load conditions. It defines the Integrated Part-Load Value (IPLV) as an excellent method of comparing diverse types of equipment on an equal basis. The IPLV is a single number estimate of a chiller's power use weighted for the number of hours the unit might spend at each part-load point. IPLV's are based on Standard Rating Conditions.

The formula for calculating an IPLV is:

$$IPLV = \frac{1}{\frac{0.01}{A} + \frac{0.42}{B} + \frac{0.45}{C} + \frac{0.12}{D}}$$

where: **A= kW/ton at 100% load point**
B= kW/ton at 75% load point
C= kW/ton at 50% load point
D= kW/ton at 25% load point



PHYSICAL SPECIFICATIONS

ACHX-B (Microchannel Condenser - Standard)

Model ACHX-B		90S	90T	120S	120T	150S	150T	170S	180T
Cooling Capacity	TR	90	92	118.5	115	150	150	163.5	185.5
	kW	317	324	417	404	528	528	575	652
Power Input	kW	104.1	104.26	121.93	130.47	151.57	163.42	170.89	202.4
Energy efficiency	kW/TR	1.157	1.133	1.029	1.135	1.01	1.089	1.045	1.091
COP	kW/kWi	3.041	3.103	3.418	3.096	3.481	3.228	3.365	3.223
Compressor									
Qty.		1	2	1	2	1	2	1	2
RPM		2950	2950	2950	2950	2950	2950	2950	2950
Oil Charge	Litres	23.5	34	39.5	39	45.5	44	45.5	47
Min. % Unit Capacity Reduction		25	12.5	25	12.5	25	12.5	25	12.5
No. Of Refrigerant Circuit		1	2	1	2	1	2	1	2
Evaporator									
Model		C2R	C4R(T)	C5R	C5R(T)	1DR	1DR(T)	2ER	2FR(T)
Qty		1	1	1	1	1	1	1	1
Water Connector	inches	4	4	4	4	5	5	6	6
	mm	101.6	101.6	101.6	101.6	127	127	152.4	152.4
Nominal Water Flow	Usgpm	216	220.8	284.4	276	360	360	392.4	445.2
	l/s	13.6	13.9	17.9	17.4	22.7	22.7	24.8	28.1
Nominal Water Pressure Drop	ft.wg	10	8.5	10.7	10.2	24.9	27	21.4	21.6
	kPa	30	25.4	32.1	30.6	74.5	80.6	64	64.7
Min. Water Flow	Usgpm	126	141	160	160	138	138	163	188
	l/s	8	8.9	10.1	10.1	8.7	8.7	10.3	11.8
Max. Water Flow	Usgpm	420	471	533	533	461	461	543	625
	l/s	26.5	29.7	33.6	33.6	29.1	29.1	34.3	39.4
Min. Water Pressure Drop	ft.wg	3.8	3.8	3.8	3.8	4.5	4.8	4.4	4.6
	kPa	11.4	11.4	11.4	11.4	13.3	14.4	13.2	13.6
Max. Water Pressure Drop	ft.wg	33.2	33.2	33.2	33.4	38.9	42.2	38.5	39.9
	kPa	99.4	99.4	99.4	99.9	116.2	126	114.9	119.1
Condenser									
Total Air Flow	CFM	73710	73710	73710	73710	98280	98280	98280	122850
	CMH	125233	125233	125233	125233	166978	166978	166978	208722
Total Face Area	sq.ft	133.9	133.9	133.9	133.9	178.6	178.6	178.6	223.2
	sq.m	12.44	12.44	12.44	12.44	16.59	16.59	16.59	20.74
No. of Fans		6	6	6	6	8	8	8	10
Fan Motor HP		3	3	3	3	3	3	3	3
General									
Unit Length	inches	152	152	152	152	197 1/4	197 1/4	197 1/4	242 1/2
	mm	3860	3860	3860	3860	5010	5010	5010	6160
Unit Width	inches	89	89	89	89	89	89	89	89
	mm	2260	2260	2260	2260	2260	2260	2260	2260
Unit Height	inches	89	89	96	89	96	96	96	96
	mm	2260	2260	2440	2260	2440	2440	2440	2440
Shipping Weight	lbs	7178	8081	8278	9320	9690	10687	9766	11968
	kg	3256	3666	3755	4228	4395	4848	4430	5428
Operating Weight	lbs	7354	8289	8469	9528	9918	10916	10041	12272
	kg	3336	3760	3841	4322	4499	4951	4554	5566
Operating Charge R134a	lbs	154	154	201	201	247	247	278	293
	kg	70	70	91	91	112	112	126	133

NoteS: 1. Nominal capacity is based on evaporator in/out fluid temperature at 54/44°F, ambient temperature 95°F, evaporator fouling factor 0.0001ft².h.°F/Btu.
 2. To consult nearest Dunham-Bush sales office for computer selections other than above operating conditions



PHYSICAL SPECIFICATIONS

ACHX-B (Microchannel Condenser - Standard)

Model ACHX-B		200S	200T	240T	270T	290T	330T	350T	400T
Cooling Capacity	TR	202.4	201.41	237	265	285	325	350	395
	kW	712	708	834	932	1002	1143	1231	1389
Power Input	kW	211.09	222.08	244.18	274.1	298.44	340.7	360.66	410.04
Energy efficiency	kW/TR	1.043	1.103	1.03	1.034	1.047	1.048	1.03	1.038
COP	kW/kWi	3.372	3.190	3.414	3.4	3.359	3.355	3.413	3.388
Compressor									
Qty.		1	2	2	2	2	2	2	2
RPM		2950	2950	2950	2950	2950	2950	2950	2950
Oil Charge	Litres	90	47	79	79	91	91	135.5	135.5
Min. % Unit Capacity Reduction		12.5	12.5	12.5	12.5	12.5	12.5	12.5	12.5
No. Of Refrigerant Circuit		1	2	2	2	2	2	2	2
Evaporator									
Model		2FR	2FR(T)	EBR(T)	JCR(T)	JCR(T)	Q1R(T)	S2R(T)	S3R(T)
Qty		1	1	1	1	1	1	1	1
Water Connector	inches	6	6	6	8	8	8	8	8
	mm	152.4	152.4	152.4	203.2	203.2	203.2	203.2	203.2
Nominal Water Flow	Usgpm	471.6	471.6	568.8	636	684	780	840	948
	l/s	29.8	29.8	35.9	40.1	43.2	49.2	53	59.8
Nominal Water Pressure Drop	ft.wg	23.3	24	24	23.2	26.4	29.6	20.3	23.1
	kPa	69.7	71.7	71.7	69.2	78.9	88.4	60.6	69.2
Min. Water Flow	Usgpm	188	188	211	252	252	280	375	393
	l/s	11.8	11.8	13.3	15.9	15.9	17.6	23.7	24.8
Max. Water Flow	Usgpm	625	625	702	840	840	932	1250	1312
	l/s	39.4	39.4	44.3	53	53	58.8	78.9	82.8
Min. Water Pressure Drop	ft.wg	4.4	4.6	4	4.4	4.4	4.7	4.7	4.8
	kPa	13.3	13.6	12	13.1	13.1	14	14.2	14.2
Max. Water Pressure Drop	ft.wg	38.7	39.9	35	38.2	38.2	40.8	41.5	41.5
	kPa	115.8	119.1	104.7	114.3	114.3	121.9	124	124.1
Condenser									
Total Air Flow	CFM	122850	122850	147420	171990	171990	196560	221130	245700
	CMH	208722	208722	250467	292211	292211	333955	375700	417444
Total Face Area	sq.ft	223.2	223.2	267.8	312.5	312.5	357.1	401.8	446.4
	sq.m	20.74	20.74	24.88	29.03	29.03	33.18	37.32	41.47
No. of Fans		10	10	12	14	14	16	18	20
Fan Motor HP		3	3	3	3	3	3	3	3
General									
Unit Length	inches	242 1/2	242 1/2	287 13/16	333	333	378 3/8	423 5/8	468 7/8
	mm	6160	6160	7310	8460	8460	9610	10760	11910
Unit Width	inches	89	89	89	89	89	89	89	89
	mm	2260	2260	2260	2260	2260	2260	2260	2260
Unit Height	inches	96	96	96	96	96	96	96	96
	mm	2440	2440	2440	2440	2440	2440	2440	2440
Shipping Weight	lbs	11988	12153	15085	16580	17105	18600	20868	21820
	kg	5438	5512	6843	7521	7759	8437	9466	9897
Operating Weight	lbs	12291	12457	15435	17000	17525	19069	21504	22456
	kg	5575	5650	7001	7711	7949	8650	9754	10186
Operating Charge R134a	lbs	324	324	386	432	463	525	556	633
	kg	147	147	175	196	210	238	252	287

NoteS: 1. Nominal capacity is based on evaporator in/out fluid temperature at 54/44°F, ambient temperature 95°F, evaporator fouling factor 0.0001ft².h.°F/Btu.
 2. To consult nearest Dunham-Bush sales office for computer selections other than above operating conditions



PHYSICAL SPECIFICATIONS

ACHX-B (Aluminum Fin/ Copper Tube Condenser - Option)

Model ACHX-B		90S	90T	120S	120T	150S	150T	170S	180T
Cooling Capacity	TR	90	92	118.5	115	150	150	163.5	185.5
	kW	317	324	417	404	528	528	575	652
Power Input	kW	104.82	104.98	122.65	131.19	152.53	164.38	171.85	203.6
Energy Efficiency	kW/TR	1.165	1.141	1.035	1.141	1.017	1.096	1.051	1.098
COP	kW/kWi	3.02	3.082	3.398	3.080	3.459	3.209	3.346	3.204
Compressor									
Qty.		1	2	1	2	1	2	1	2
RPM		2950	2950	2950	2950	2950	2950	2950	2950
Oil Charge	Litres	23.5	34	39.5	39	45.5	44	45.5	47
Min. % Unit Capacity Reduction		25	12.5	25	12.5	25	12.5	25	12.5
No. Of Refrigerant Circuit		1	2	1	2	1	2	1	2
Evaporator									
Model		C2R	C4R(T)	C5R	C5R(T)	1DR	1DR(T)	2ER	2FR(T)
Qty		1	1	1	1	1	1	1	1
Water Connector	inches	4	4	4	4	5	5	6	6
	mm	101.6	101.6	101.6	101.6	127	127	152.4	152.4
Nominal Water Flow	Usgpm	216	220.8	284.4	276	360	360	392.4	445.2
	l/s	13.6	13.9	17.9	17.4	22.7	22.7	24.8	28.1
Nominal Water Pressure Drop	ft.wg	10	8.5	10.7	10.2	24.9	27	21.4	21.6
	kPa	30	25.4	32.1	30.6	74.5	80.6	64	64.7
Min. Water Flow	Usgpm	126	141	160	160	138	138	163	188
	l/s	8	8.9	10.1	10.1	8.7	8.7	10.3	11.8
Max. Water Flow	Usgpm	420	471	533	533	461	461	543	625
	l/s	26.5	29.7	33.6	33.6	29.1	29.1	34.3	39.4
Min. Water Pressure Drop	ft.wg	3.8	3.8	3.8	3.8	4.5	4.8	4.4	4.6
	kPa	11.4	11.4	11.4	11.4	13.3	14.4	13.2	13.6
Max. Water Pressure Drop	ft.wg	33.2	33.2	33.2	33.4	38.9	42.2	38.5	39.9
	kPa	99.4	99.4	99.4	99.9	116.2	126	114.9	119.1
Condenser									
Total Air Flow	CFM	89460	89460	89460	89460	119280	119280	119280	149100
	CMH	151993	151993	151993	151993	202657	202657	202657	253321
Total Face Area	sq.ft	141.2	141.2	141.2	141.2	188.2	188.2	188.2	235.3
	sq.m	13.11	13.11	13.11	13.11	17.49	17.49	17.49	21.86
No. of Fans		6	6	6	6	8	8	8	10
Fan Motor HP		3	3	3	3	3	3	3	3
General									
Unit Length	inches	152	152	152	152	197 1/4	197 1/4	197 1/4	242 1/2
	mm	3860	3860	3860	3860	5010	5010	5010	6160
Unit Width	inches	89	89	89	89	89	89	89	89
	mm	2260	2260	2260	2260	2260	2260	2260	2260
Unit Height	inches	89	89	96	89	96	96	96	96
	mm	2260	2260	2440	2260	2440	2440	2440	2440
Shipping Weight	lbs	7725	8629	8826	9868	10420	11417	10496	12880
	kg	3504	3914	4003	4476	4726	5179	4761	5842
Operating Weight	lbs	7901	8836	9016	10075	10648	11646	10771	13184
	kg	3584	4008	4090	4570	4830	5282	4885	5980
Operating Charge R134a	lbs	220	220	287	287	353	353	397	419
	kg	100	100	130	130	160	160	180	190

Notes: 1. Nominal capacity is based on evaporator in/out fluid temperature at 54/44°F, ambient temperature 95°F, evaporator fouling factor 0.0001ft².h.°F/Btu.
 2. To consult nearest Dunham-Bush sales office for computer selections other than above operating conditions



PHYSICAL SPECIFICATIONS

ACHX-B (Aluminum Fin/ Copper Tube Condenser - Option)

Model ACHX-B		200S	200T	240T	270T	290T	330T	350T	400T
Cooling Capacity	TR	202.4	201.41	237	265	285	325	350	395
	kW	712	708	834	932	1002	1143	1231	1389
Power Input	kW	212.29	223.28	245.62	275.8	300.12	342.62	362.82	412.44
Energy Efficiency	kW/TR	1.049	1.109	1.036	1.041	1.053	1.054	1.037	1.044
COP	kW/kWi	3.353	3.173	3.394	3.379	3.34	3.336	3.393	3.368
Compressor									
Qty.		1	2	2	2	2	2	2	2
RPM		2950	2950	2950	2950	2950	2950	2950	2950
Oil Charge	Litres	90	47	79	79	91	91	135.5	135.5
Min. % Unit Capacity Reduction		12.5	12.5	12.5	12.5	12.5	12.5	12.5	12.5
No. Of Refrigerant Circuit		1	2	2	2	2	2	2	2
Evaporator									
Model		2FR	2FR(T)	EBR(T)	JCR(T)	JCR(T)	Q1R(T)	S2R(T)	S3R(T)
Qty		1	1	1	1	1	1	1	1
Water Connector	inches	6	6	6	8	8	8	8	8
	mm	152.4	152.4	152.4	203.2	203.2	203.2	203.2	203.2
Nominal Water Flow	Usgpm	471.6	471.6	568.8	636	684	780	840	948
	l/s	29.8	29.8	35.9	40.1	43.2	49.2	53	59.8
Nominal Water Pressure Drop	ft.wg	23.3	24	24	23.2	26.4	29.6	20.3	23.1
	kPa	69.7	71.7	71.7	69.2	78.9	88.4	60.6	69.2
Min. Water Flow	Usgpm	188	188	211	252	252	280	375	393
	l/s	11.8	11.8	13.3	15.9	15.9	17.6	23.7	24.8
Max. Water Flow	Usgpm	625	625	702	840	840	932	1250	1312
	l/s	39.4	39.4	44.3	53	53	58.8	78.9	82.8
Min. Water Pressure Drop	ft.wg	4.4	4.6	4	4.4	4.4	4.7	4.7	4.8
	kPa	13.3	13.6	12	13.1	13.1	14	14.2	14.2
Max. Water Pressure Drop	ft.wg	38.7	39.9	35	38.2	38.2	40.8	41.5	41.5
	kPa	115.8	119.1	104.7	114.3	114.3	121.9	124	124.1
Condenser									
Total Air Flow	CFM	149100	149100	178920	208740	208740	238560	268380	298200
	CMH	253321	253321	303985	354649	354649	405313	455978	506642
Total Face Area	sq.ft	235.3	235.3	282.3	329.4	329.4	376.4	423.5	470.6
	sq.m	21.86	21.86	26.23	30.6	30.6	34.97	39.34	43.72
No. of Fans		10	10	12	14	14	16	18	20
Fan Motor HP		3	3	3	3	3	3	3	3
General									
Unit Length	inches	242 1/2	242 1/2	287 13/16	333	333	378 3/8	423 5/8	468 7/8
	mm	6160	6160	7310	8460	8460	9610	10760	11910
Unit Width	inches	89	89	89	89	89	89	89	89
	mm	2260	2260	2260	2260	2260	2260	2260	2260
Unit Height	inches	96	96	96	96	96	96	96	96
	mm	2440	2440	2440	2440	2440	2440	2440	2440
Shipping Weight	lbs	12901	13065	16180	17857	18382	20060	22510	23645
	kg	5852	5926	7339	8100	8338	9099	10211	10725
Operating Weight	lbs	13204	13369	16530	18277	18802	20529	23146	24281
	kg	5989	6064	7498	8290	8529	9312	10499	11014
Operating Charge R134a	lbs	463	463	551	617	661	750	794	904
	kg	210	210	250	280	300	340	360	410

Notes: 1. Nominal capacity is based on evaporator in/out fluid temperature at 54/44°F, ambient temperature 95°F, evaporator fouling factor 0.0001ft².°F/Btu.
 2. To consult nearest Dunham-Bush sales office for computer selections other than above operating conditions



ELECTRICAL DATA

Model ACHX-B	Power Supply : 400Vac-3Ph-50Hz										
	Cond. Fan Motor Data			Compressor Data			Unit Electrical Data				
	Operation At 95°F Ambient Temperature										
	Qty	HP	FLA	Starter Type	Qty	LRA	Compr RLA	Unit RLA	MCA	MFS	Max Inrush
90S	6	3	5.3	Star-Delta	1	987	152	184	222	350	361
90T	6	3	5.3	Star-Delta	2	461	76	184	203	250	246
120S	6	3	5.3	Star-Delta	1	1259	183	214	260	400	452
120T	6	3	5.3	Star-Delta	1	461	78	229	259	350	361
				Star-Delta	1	815	119				
150S	8	3	5.3	Star-Delta	1	1372	225	267	323	500	500
150T	8	3	5.3	Star-Delta	2	815	122	287	318	400	415
170S	8	3	5.3	Star-Delta	1	1512	258	300	364	600	547
180T	10	3	5.3	Star-Delta	2	987	151	356	394	500	507
200S	10	3	5.3	Star-Delta	1	1816	318	371	450	700	707
200T	10	3	5.3	Star-Delta	2	987	168	389	431	600	524
240T	12	3	5.3	Star-Delta	2	1259	183	429	475	600	635
270T	14	3	5.3	Star-Delta	2	1259	204	483	534	700	661
290T	14	3	5.3	Star-Delta	2	1372	225	524	580	800	720
330T	16	3	5.3	Star-Delta	2	1512	257	598	662	800	804
350T	18	3	5.3	Star-Delta	1	1512	248	634	707	1000	950
				Star-Delta	1	1816	291				
400T	20	3	5.3	Star-Delta	1	1512	283	721	804	1000	990
				Star-Delta	1	1816	331				

RLA - Running Load Amps At 95 °F Ambient Temperature; MCA - Minimum Circuit Ampacity; MFS - Maximum Fuse Size; LRA - Lock Rotor Amp
 Note: Standard Star-Delta starter is open transition type.

SOUND PRESSURE DATA

Model ACHX-B	Octave Band (Hz)								Total dB(A)
	63	125	250	500	1K	2K	4K	8K	
90S	51	54	58	58	63	59	54	42	67
90T	49	53	57	57	60	56	50	40	64
120S	52	54	58	58	64	60	54	42	67
120T	51	55	58	58	62	58	52	42	66
150S	52	55	59	59	64	60	54	43	68
150T	52	55	58	58	63	59	54	42	67
170S	53	55	59	59	65	61	55	43	68
180T	54	56	60	60	65	62	56	45	69
200S	54	56	60	60	66	63	57	44	70
200T	54	56	60	60	65	62	56	45	69
240T	54	57	61	60	66	63	57	45	70
270T	54	57	61	61	66	63	57	45	70
290T	55	57	61	61	66	63	57	45	70
330T	55	58	62	61	67	64	58	46	71
350T	56	58	62	62	68	65	59	46	71
400T	56	58	62	62	68	64	59	46	72

Note: Unit Sound Pressure Level (Lp) @ 33 ft [10m] (free field), ± 2 dB(A) tolerance.

DIMENSIONAL DATA

ACHX-B 90S

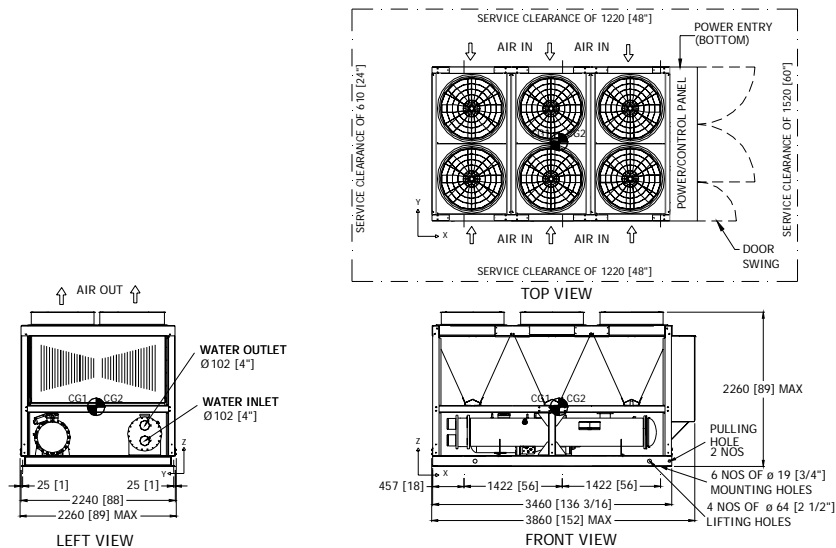

ACHX-B 90T

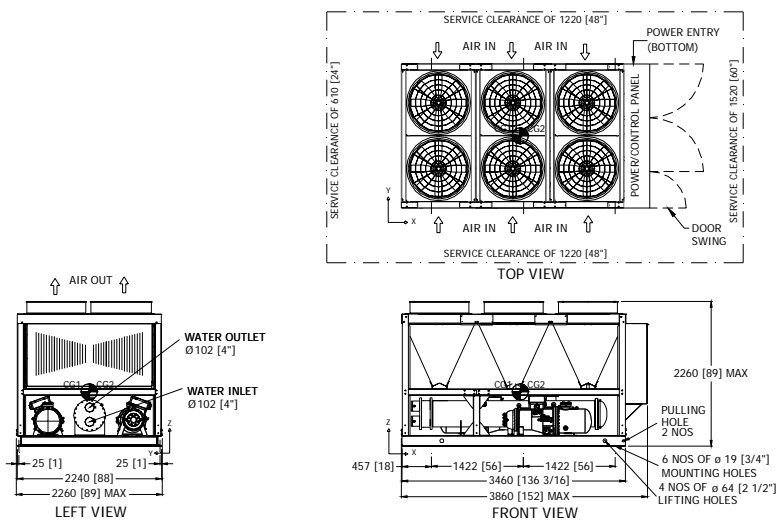

ACHX-B 120S

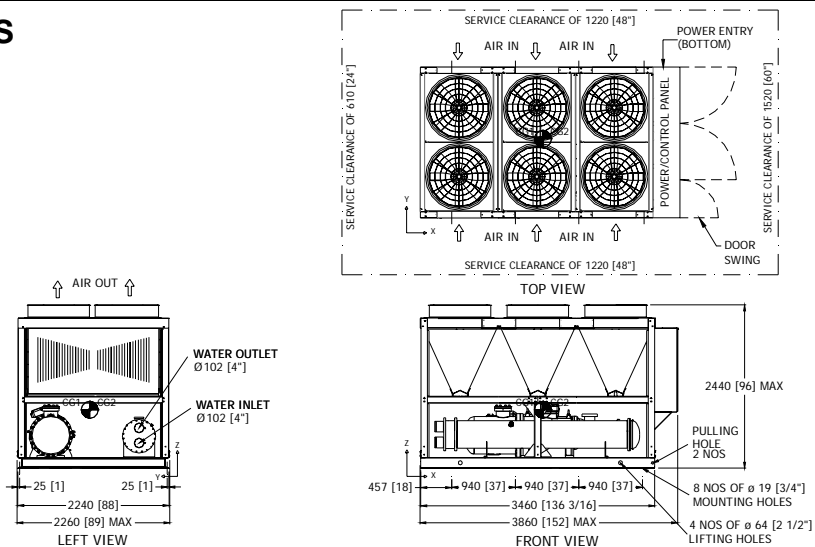

Note: All dimensions are in mm[inches].

DIMENSIONAL DATA

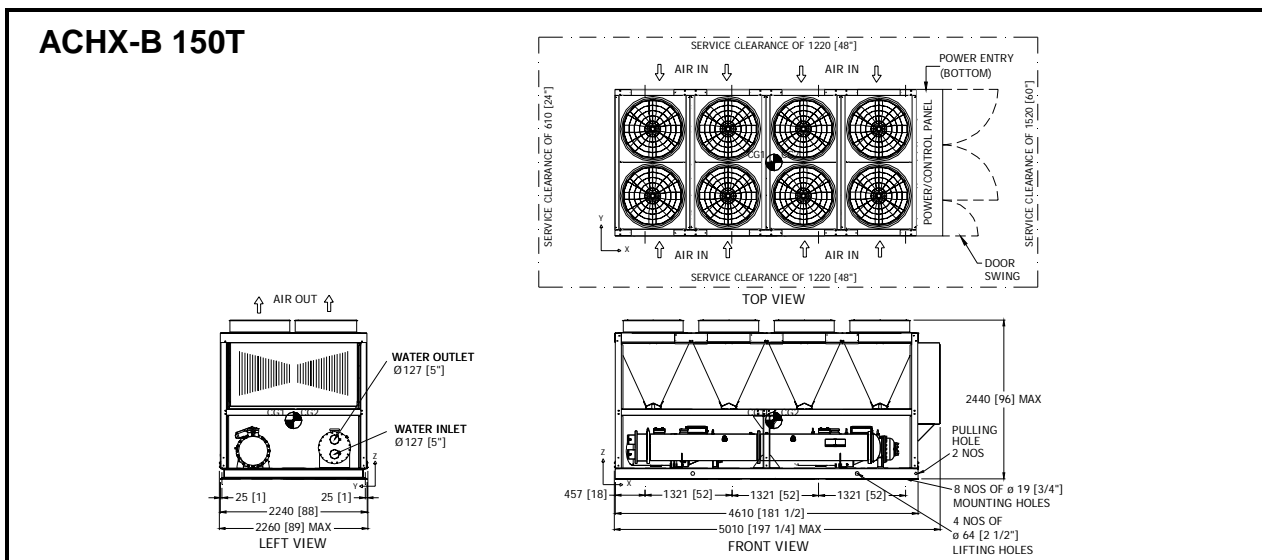
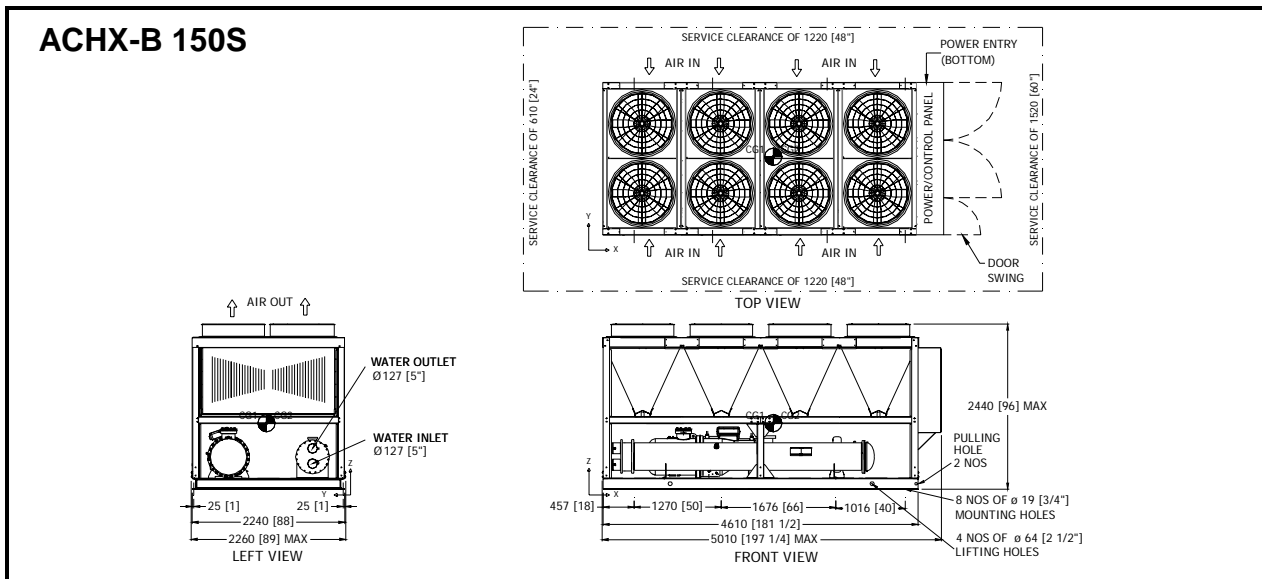
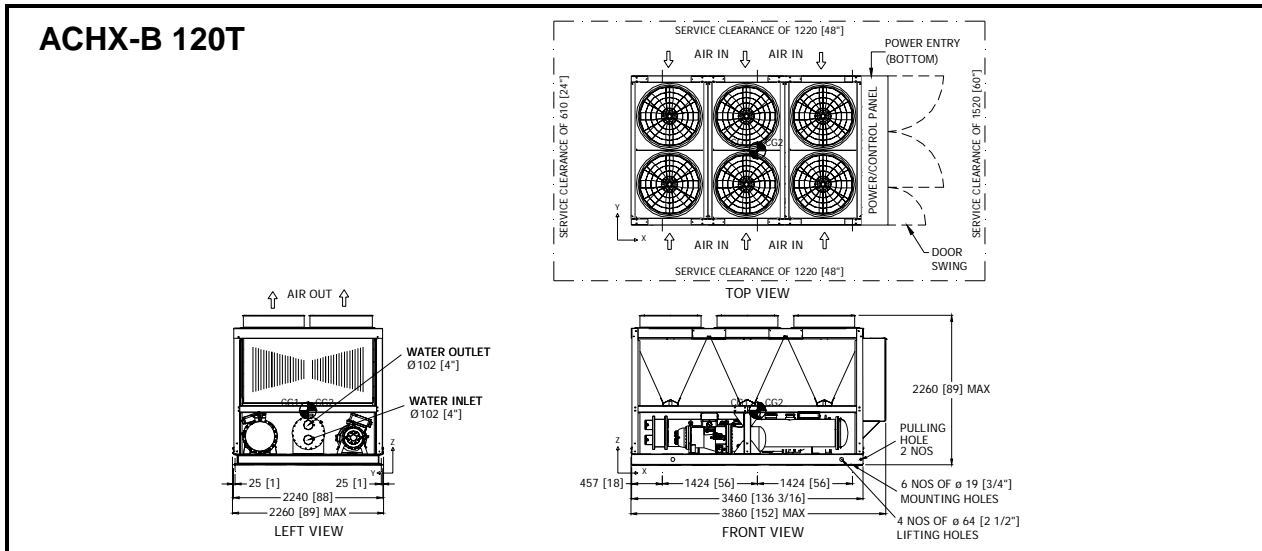

Note: All dimensions are in mm[inches].

DIMENSIONAL DATA

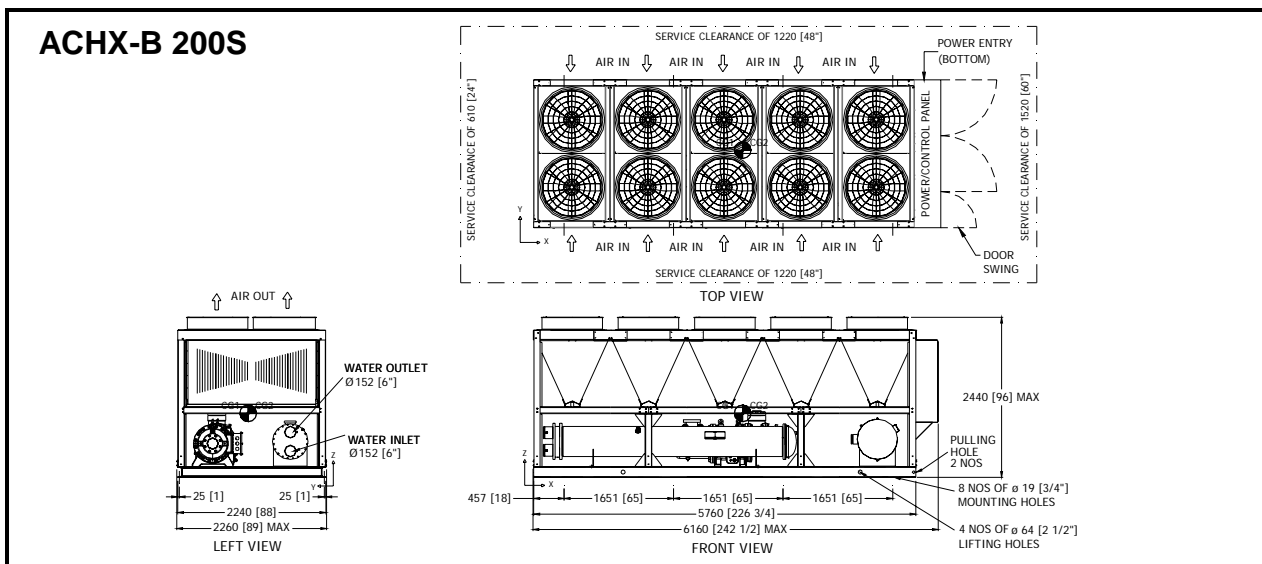
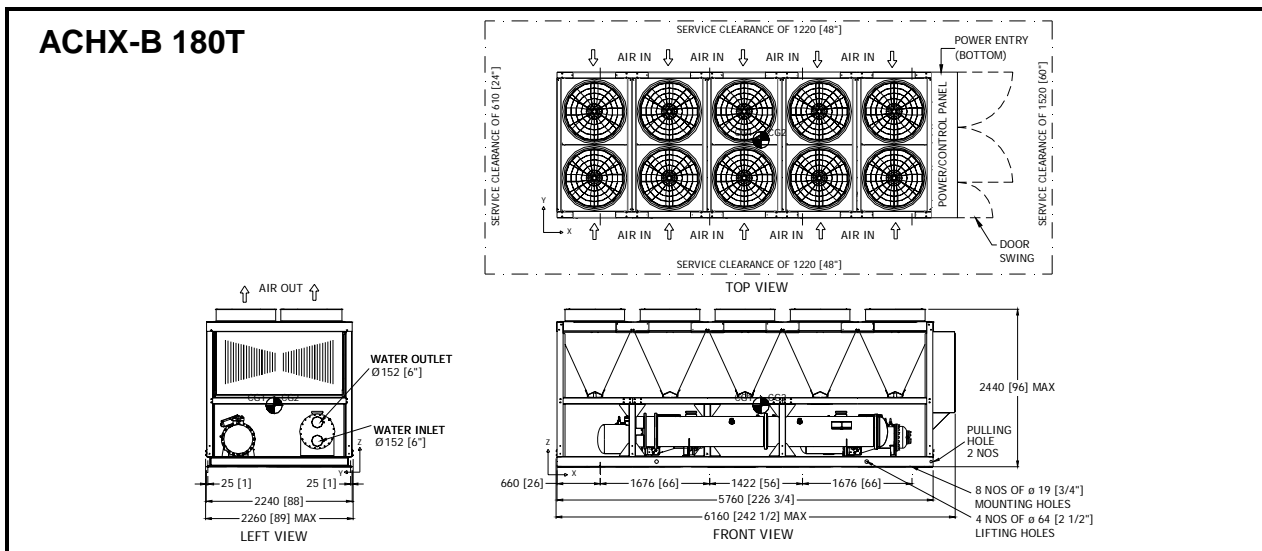
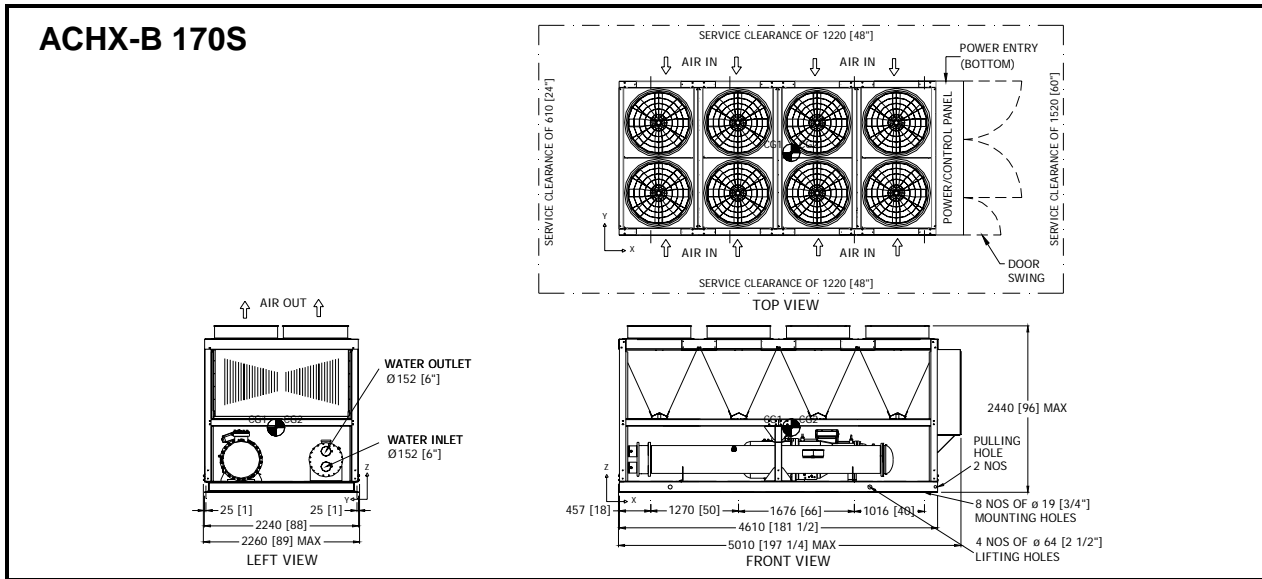

Note: All dimensions are in mm[inches].

DIMENSIONAL DATA

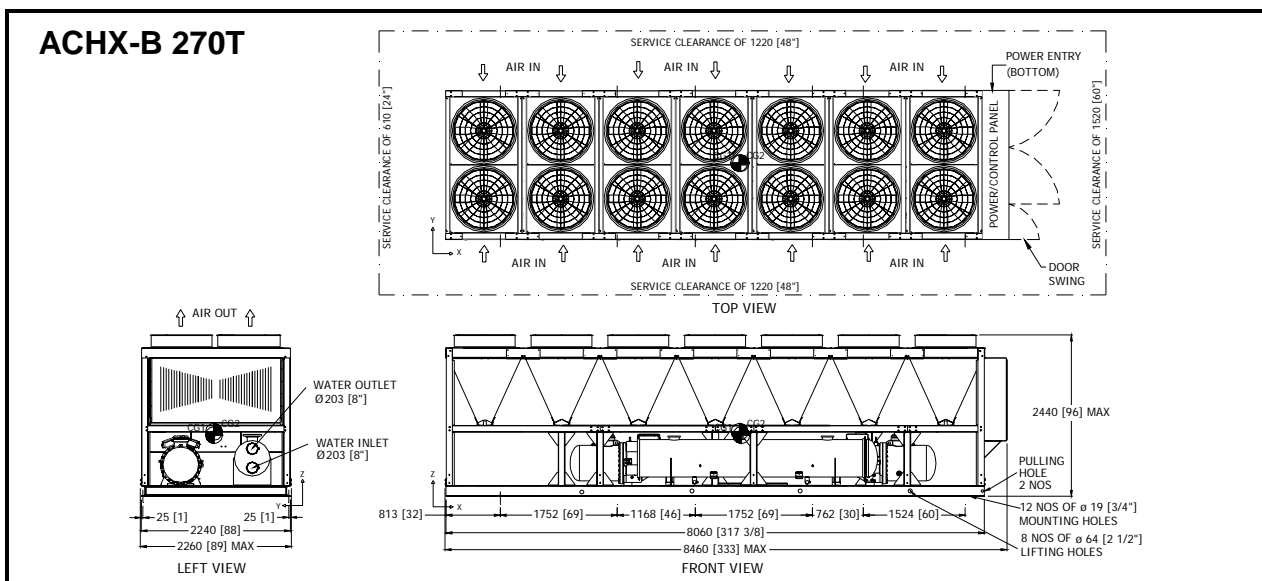
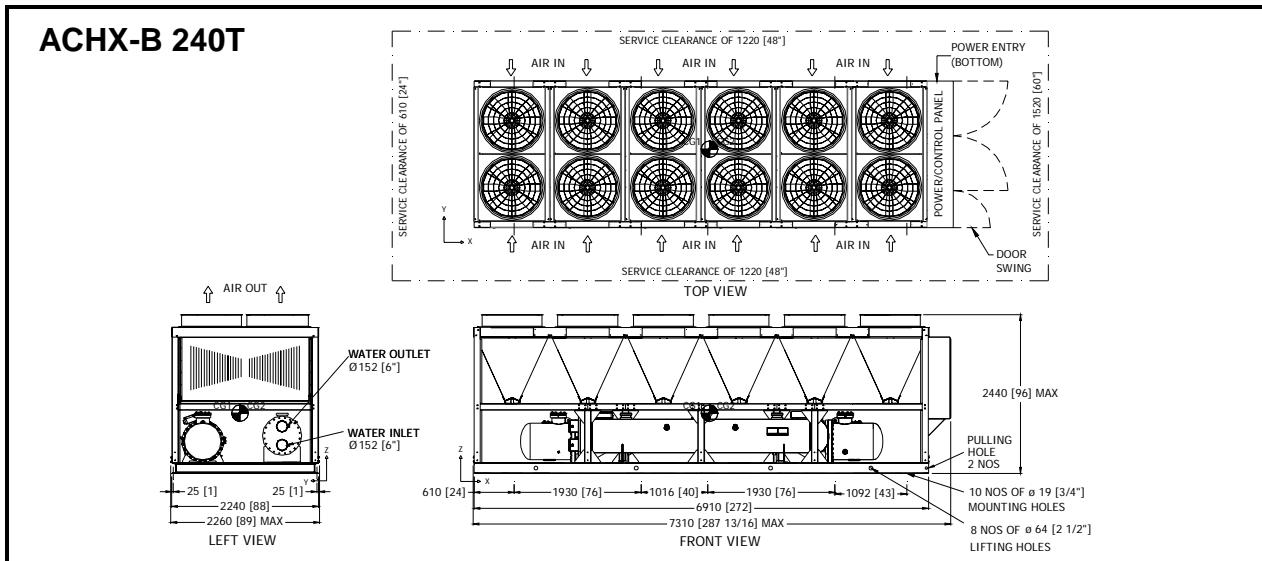
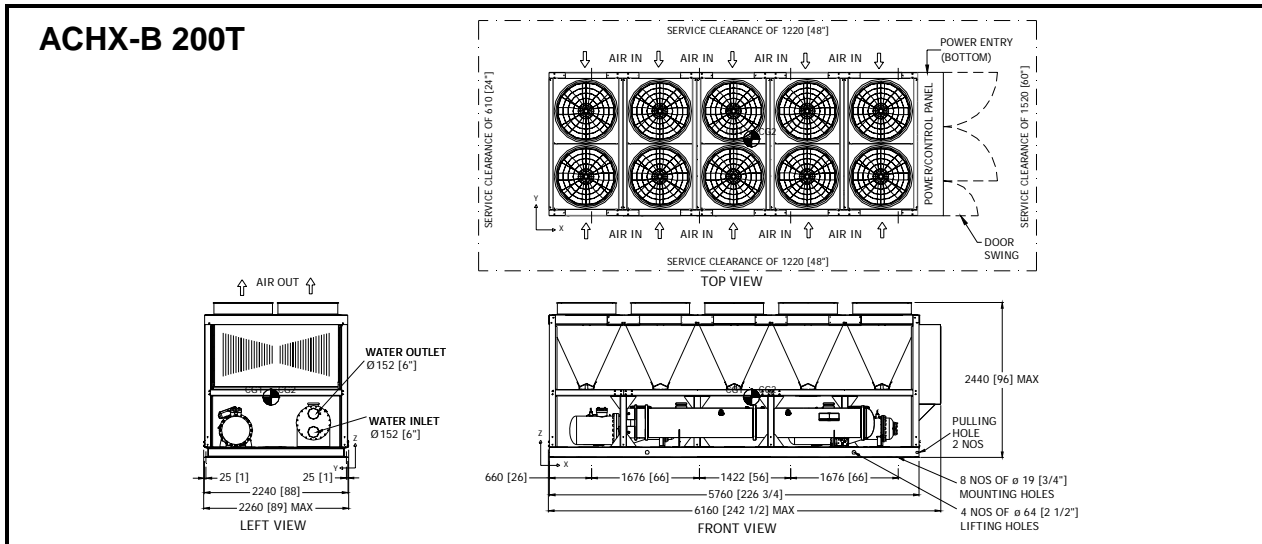

Note: All dimensions are in mm[inches].

DIMENSIONAL DATA

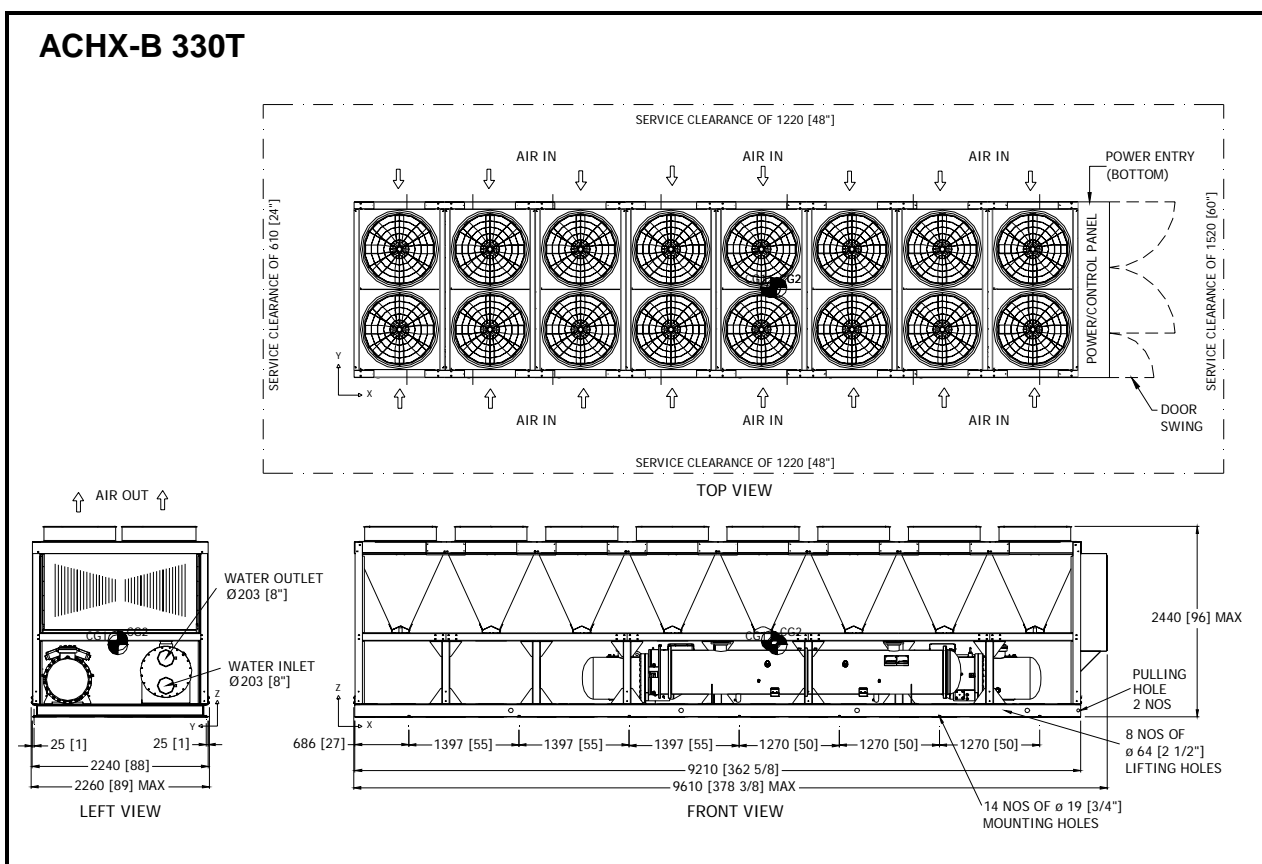
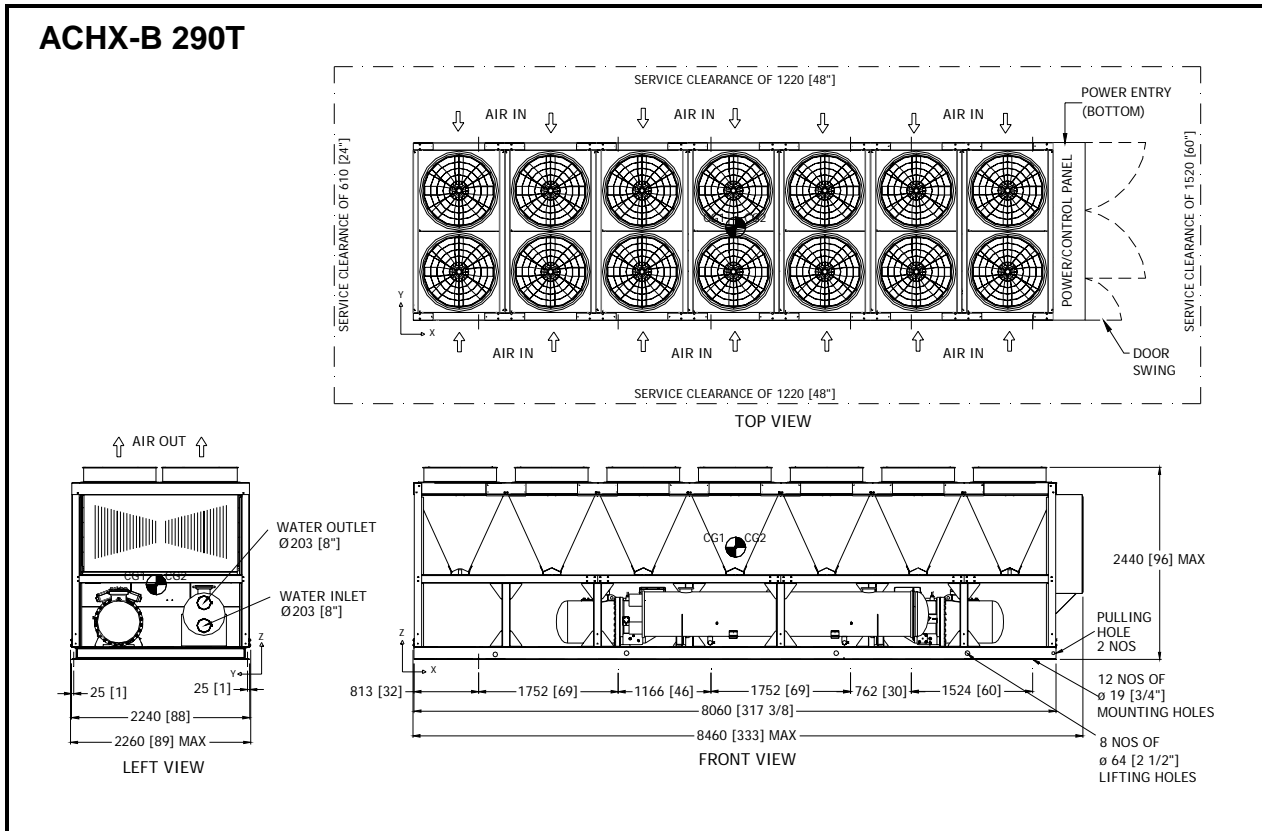

Note: All dimensions are in mm[inches].

DIMENSIONAL DATA

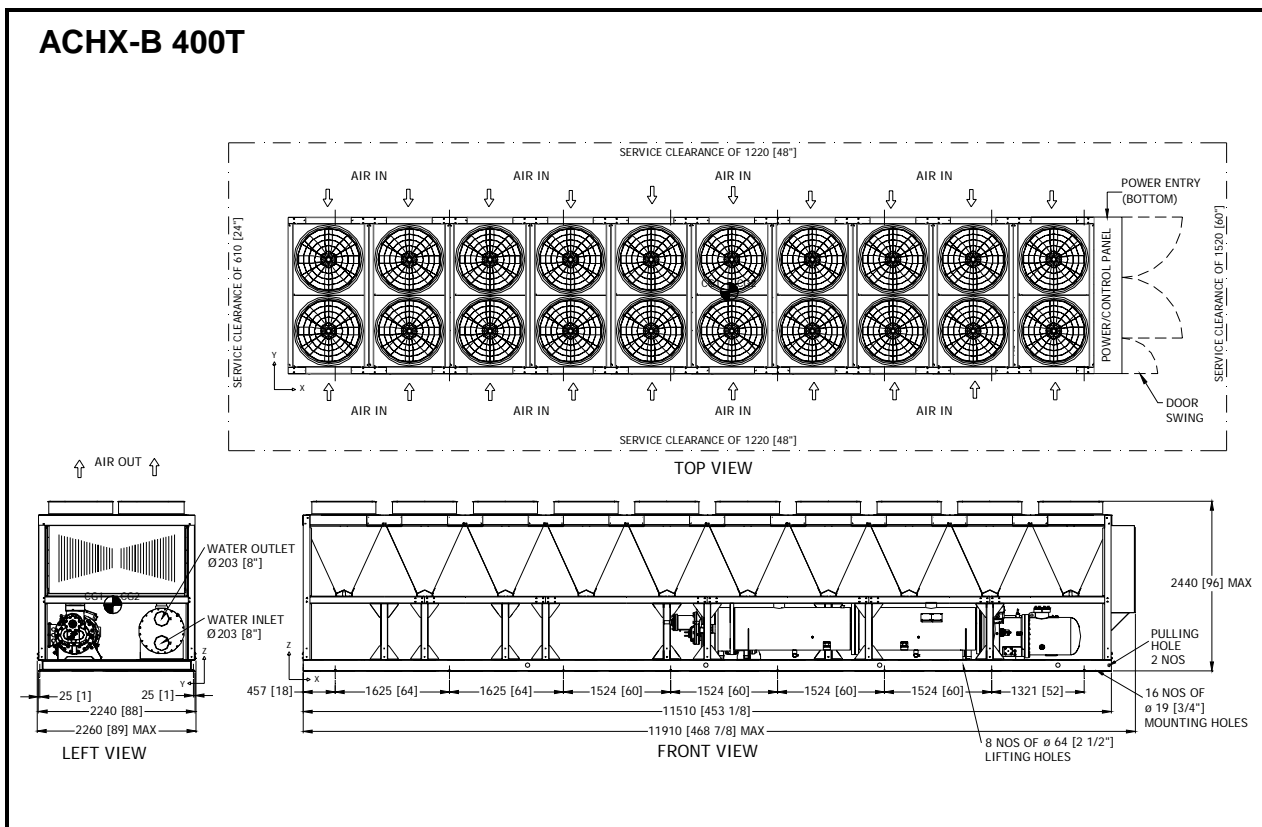
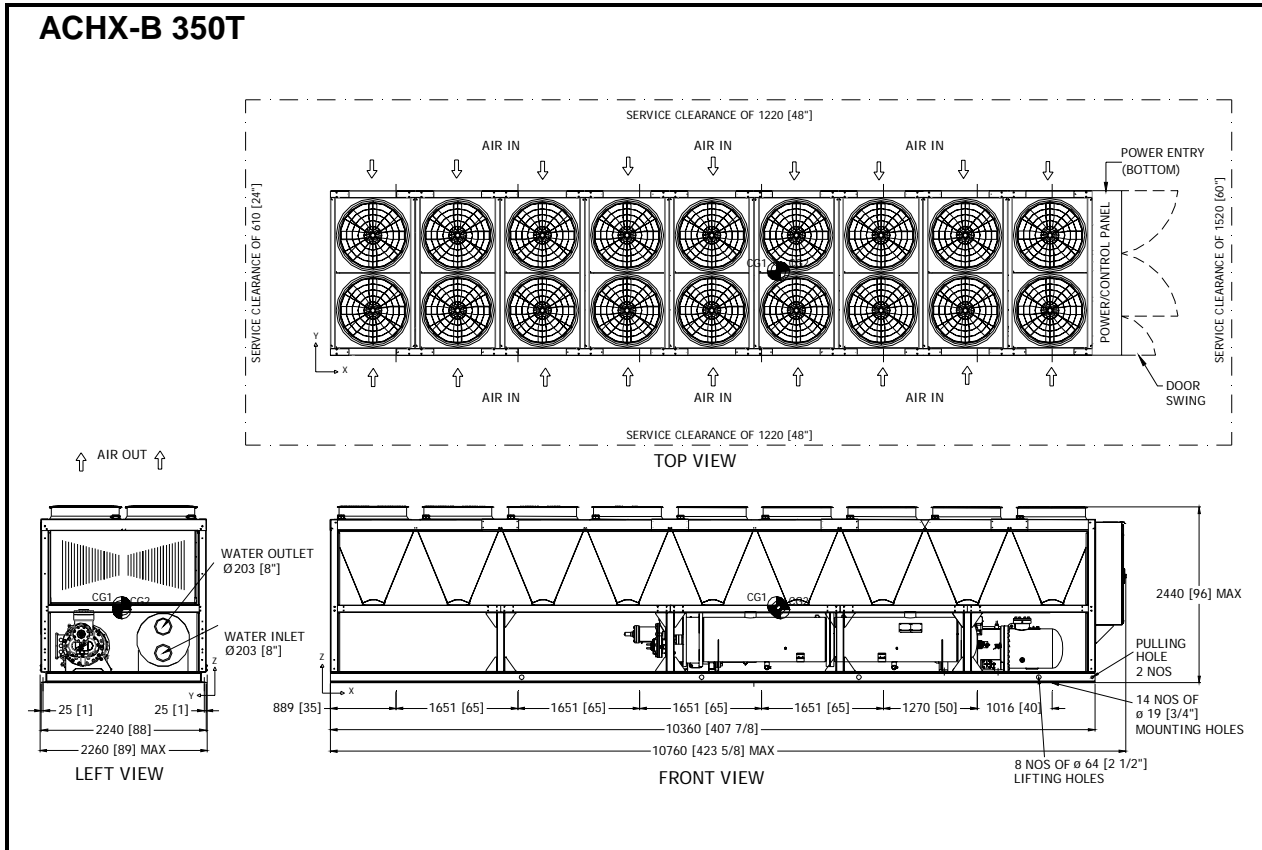

Note: All dimensions are in mm[inches].

FLOOR LOADING DIAGRAM

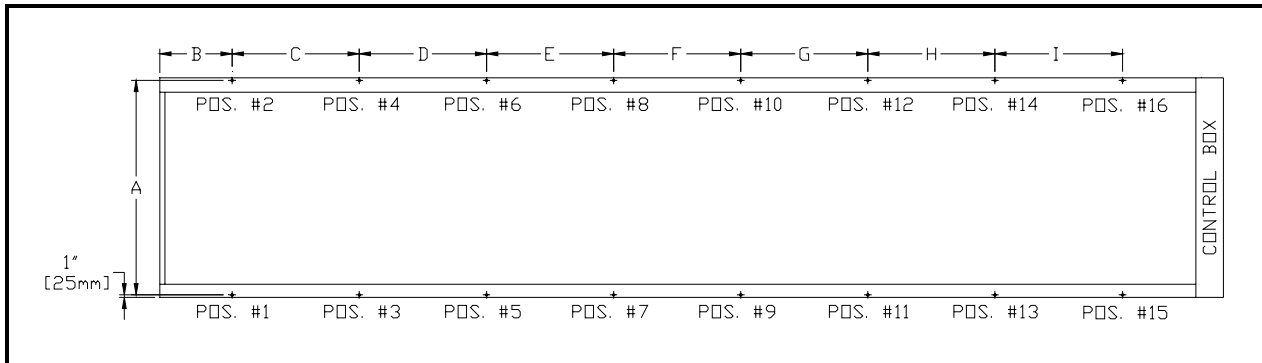

a.) Point Load Location – inches [mm]

Model ACHX-B	A	B	C	D	E	F	G	H	I
90S	86 [2184]	18 [457]	56 [1424]	56 [1424]	-	-	-	-	-
90T	86 [2184]	18 [457]	56 [1424]	56 [1424]	-	-	-	-	-
120S	86 [2184]	18 [457]	37 [940]	37 [940]	37 [940]	-	-	-	-
120T	86 [2184]	18 [457]	56 [1424]	56 [1424]	-	-	-	-	-
150S	86 [2184]	18 [457]	50 [1270]	66 [1676]	40 [1016]	-	-	-	-
150T	86 [2184]	18 [457]	52 [1321]	52 [1321]	52 [1321]	-	-	-	-
170S	86 [2184]	18 [457]	50 [1270]	66 [1676]	40 [1016]	-	-	-	-
180T	86 [2184]	26 [660]	66 [1676]	56 [1422]	66 [1676]	-	-	-	-
200S	86 [2184]	18 [457]	65 [1651]	65 [1651]	65 [1651]	-	-	-	-
200T	86 [2184]	26 [660]	66 [1676]	56 [1422]	66 [1676]	-	-	-	-
240T	86 [2184]	24 [610]	76 [1930]	40 [1016]	76 [1930]	43 [1092]	-	-	-
270T	86 [2184]	32 [813]	69 [1752]	46 [1168]	69 [1752]	30 [762]	60 [1524]	-	-
290T	86 [2184]	32 [813]	69 [1752]	46 [1166]	69 [1752]	30 [762]	60 [1524]	-	-
330T	86 [2184]	26 [686]	55 [1397]	55 [1397]	55 [1397]	50 [1270]	50 [1270]	50 [1270]	-
350T	86 [2184]	35 [889]	65 [1651]	65 [1651]	65 [1651]	65 [1651]	50 [1270]	40 [1016]	-
400T	86 [2184]	18 [457]	64 [1625]	64 [1625]	60 [1524]	60 [1524]	60 [1524]	60 [1524]	52 [1321]

b.) Point Load Data for Microchannel – lbs [kg]

Model ACHX-B	P1	P2	P3	P4	P5	P6	P7	P8	P9	P10	P11	P12	P13	P14	P15	P16	Total Operating Weight
90S	1181 [536]	941 [427]	1385 [628]	1929 [875]	1082 [491]	837 [380]	-	-	-	-	-	-	-	-	-	-	7354 [3336]
90T	1329 [603]	1303 [591]	1662 [754]	1792 [813]	1143 [519]	1060 [481]	-	-	-	-	-	-	-	-	-	-	8289 [3760]
120S	1001 [454]	948 [430]	1131 [513]	1455 [660]	1062 [481]	1177 [534]	880 [399]	817 [371]	-	-	-	-	-	-	-	-	8469 [3841]
120T	1751 [794]	1473 [668]	1616 [733]	1633 [741]	1408 [638]	1646 [746]	-	-	-	-	-	-	-	-	-	-	9528 [4322]
150S	1309 [594]	1029 [467]	1033 [469]	1067 [484]	1801 [817]	1984 [900]	820 [372]	874 [397]	-	-	-	-	-	-	-	-	9918 [4499]
150T	1259 [571]	1250 [567]	1321 [599]	1617 [733]	1470 [667]	1533 [695]	1086 [493]	1380 [626]	-	-	-	-	-	-	-	-	10916 [4951]
170S	1200 [544]	934 [423]	1096 [497]	1150 [522]	1824 [827]	2094 [950]	796 [361]	946 [429]	-	-	-	-	-	-	-	-	10041 [4554]
180T	1160 [526]	1338 [607]	1752 [795]	1845 [837]	1507 [684]	1840 [834]	1409 [639]	1421 [644]	-	-	-	-	-	-	-	-	12272 [5566]
200S	1446 [656]	1199 [544]	1370 [621]	1765 [801]	1742 [790]	1981 [898]	1337 [607]	1451 [658]	-	-	-	-	-	-	-	-	12291 [5575]
200T	1226 [556]	1564 [709]	1692 [767]	1600 [726]	1402 [636]	1442 [654]	1574 [714]	1957 [888]	-	-	-	-	-	-	-	-	12457 [5650]
240T	1209 [548]	1353 [614]	1985 [900]	2036 [923]	1369 [621]	1443 [655]	1597 [724]	1933 [877]	1219 [553]	1289 [585]	-	-	-	-	-	-	15435 [7001]
270T	950 [431]	965 [438]	1279 [580]	1384 [628]	1930 [875]	1880 [853]	1853 [841]	1765 [801]	1434 [651]	1679 [761]	918 [416]	963 [437]	-	-	-	-	17000 [7711]
290T	996 [452]	1010 [458]	1302 [590]	1422 [645]	1422 [888]	1958 [879]	1900 [862]	1831 [831]	1484 [673]	1750 [794]	943 [428]	991 [449]	-	-	-	-	17525 [7949]
330T	832 [377]	857 [389]	954 [433]	990 [449]	1376 [624]	2029 [920]	1908 [865]	1349 [612]	1371 [622]	1159 [526]	1631 [740]	1793 [813]	1301 [590]	1521 [690]	-	-	19069 [8650]
350T	924 [419]	922 [418]	1289 [584]	1297 [588]	1738 [789]	1906 [865]	1730 [785]	1498 [680]	1566 [710]	1354 [614]	2100 [952]	2207 [1001]	1408 [639]	1565 [710]	-	-	21504 [9754]
400T	886 [402]	901 [409]	842 [382]	842 [382]	1110 [503]	1109 [503]	1441 [654]	1436 [651]	2028 [920]	2007 [910]	1211 [549]	1204 [546]	2020 [916]	2133 [967]	1694 [769]	1592 [722]	22456 [10186]

FLOOR LOADING DIAGRAM

c.) Point Load Data for Cu/Al – lbs [kg]

Model ACHX-B	P1	P2	P3	P4	P5	P6	P7	P8	P9	P10	P11	P12	P13	P14	P15	P16	Total Operating Weight
90S	1280 [581]	1040 [472]	1491 [676]	2036 [923]	1150 [522]	905 [410]	-	-	-	-	-	-	-	-	-	-	7901 [3584]
90T	1428 [648]	1402 [636]	1769 [802]	1898 [861]	1211 [549]	1128 [512]	-	-	-	-	-	-	-	-	-	-	8836 [4008]
120S	1092 [495]	1039 [471]	1198 [544]	1522 [690]	1122 [509]	1237 [561]	934 [424]	872 [395]	-	-	-	-	-	-	-	-	9016 [4090]
120T	1850 [839]	1573 [713]	1723 [782]	1740 [789]	1475 [669]	1713 [777]	-	-	-	-	-	-	-	-	-	-	10075 [4570]
150S	1406 [638]	1121 [508]	1161 [527]	1187 [539]	1895 [859]	2051 [930]	909 [412]	919 [417]	-	-	-	-	-	-	-	-	10648 [4830]
150T	1351 [613]	1343 [609]	1434 [650]	1730 [785]	1563 [709]	1626 [738]	1153 [523]	1446 [656]	-	-	-	-	-	-	-	-	11646 [5282]
170S	1295 [587]	1028 [466]	1220 [553]	1275 [578]	1904 [864]	2174 [986]	863 [391]	1013 [459]	-	-	-	-	-	-	-	-	10771 [4885]
180T	1289 [585]	1467 [665]	1862 [844]	1954 [887]	1626 [738]	1959 [888]	1508 [684]	1520 [689]	-	-	-	-	-	-	-	-	13184 [5980]
200S	1568 [711]	1321 [599]	1490 [676]	1886 [855]	1872 [849]	2110 [957]	1422 [645]	1535 [696]	-	-	-	-	-	-	-	-	13204 [5989]
200T	1355 [614]	1693 [768]	1801 [817]	1709 [775]	1521 [690]	1561 [708]	1673 [759]	2056 [932]	-	-	-	-	-	-	-	-	13369 [6064]
240T	1343 [609]	1487 [675]	2096 [951]	2147 [974]	1473 [668]	1547 [702]	1702 [772]	2038 [924]	1312 [595]	1382 [627]	-	-	-	-	-	-	16530 [7498]
270T	1068 [485]	1084 [492]	1391 [631]	1497 [679]	2038 [924]	1988 [902]	1947 [883]	1859 [843]	1559 [707]	1803 [818]	1000 [454]	1045 [474]	-	-	-	-	18277 [8290]
290T	1114 [505]	1128 [512]	1414 [642]	1534 [696]	2066 [937]	2047 [929]	1993 [904]	1608 [873]	1874 [730]	1025 [850]	1073 [465]	-	-	-	-	-	18802 [8529]
330T	947 [430]	972 [441]	1052 [477]	1089 [494]	1471 [667]	2124 [963]	2007 [911]	1448 [657]	1473 [668]	1261 [572]	1745 [791]	1907 [865]	1407 [638]	1627 [738]	-	-	20529 [9312]
350T	1042 [473]	1041 [472]	1407 [638]	1415 [642]	1870 [848]	2038 [925]	1833 [831]	1601 [726]	1702 [772]	1490 [676]	2197 [997]	2304 [1045]	1524 [691]	1681 [762]	-	-	23146 [10499]
400T	1001 [454]	1016 [461]	951 [431]	951 [431]	1221 [554]	1220 [553]	1585 [719]	1579 [716]	2131 [967]	2111 [957]	1314 [596]	1307 [593]	2156 [978]	2269 [1029]	1786 [810]	1683 [763]	24281 [11014]

FIELD POWER & CONTROL WIRING SCHEMATIC

TYPICAL FIELD WIRING DIAGRAM

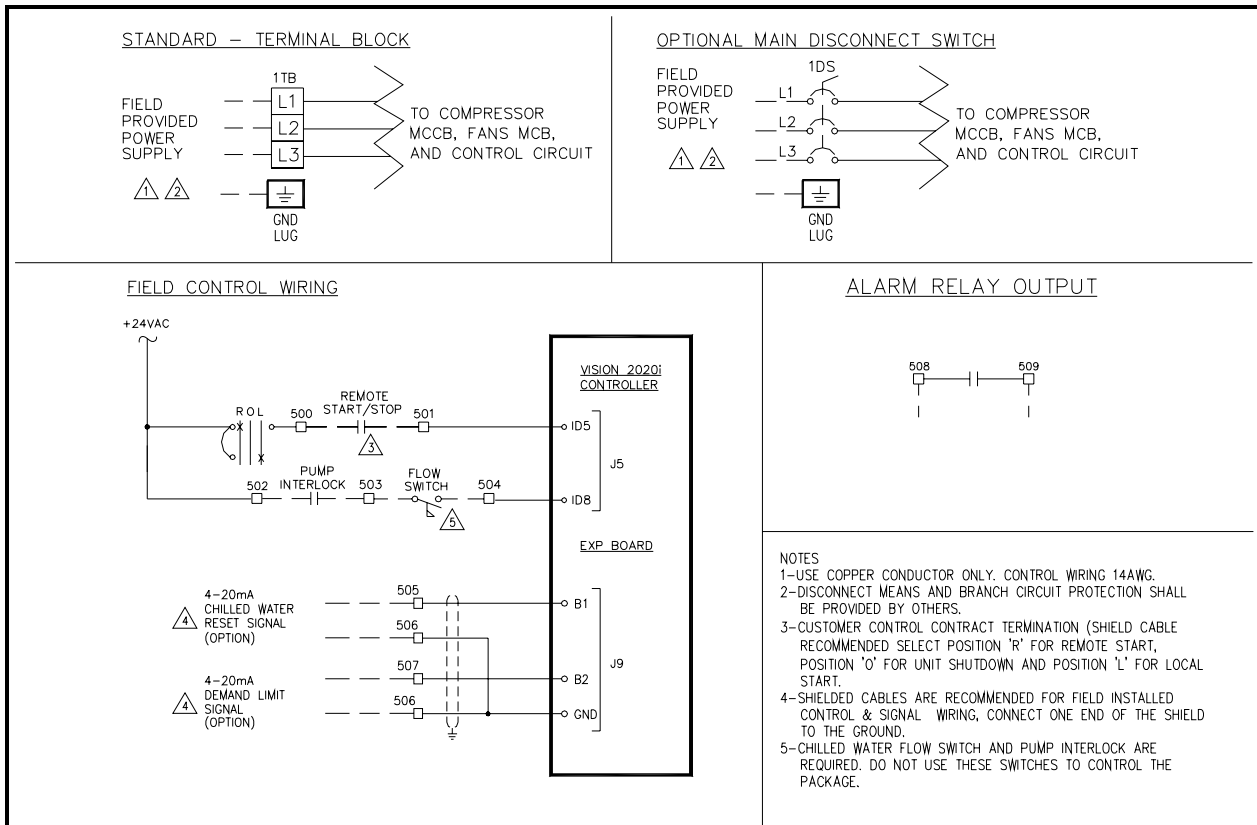

APPLICATION DATA

UNIT DESIGNED OPERATING RANGE

Unit Operating Range – Ambient Temperature

The units are designed to operate at ambient temperature, 45~115°F [7~46°C]. If the unit requires to be operated at lower ambient temperature, the optional Low Ambient Operation (LA 1), or Extra Low Ambient Operation (LA 2) shall be incorporated for stable operation.

Operating Limits – Ambient Temperature

Operating Ambient Temperature	Minimum	Maximum
Standard	45°F [7°C]	115°F [46°C]
With LA 1	14°F [-10°C]	115°F [46°C]
With LA 2	-20°F [-29°C]	115°F [46°C]

If wind velocity in the area is over 5 mph [8 kmph], wind barrier is recommended.

Unit Operating Range – Evaporator Temperature

The unit is designed to deliver chilled fluid temperature within 40~50°F [4.5~10°C]. The unit can start and pull down with up to 80°F [27°C] entering-fluid temperature. For sustained operation, it is recommended that the entering fluid temperature not exceed 70°F [21°C].

For unit installation with minimum ambient temperature at 32°F [0°C] or below, Evaporator Anti-Freeze Protection option is recommended to prevent freezing of water in evaporator when the chiller is not in operation.

Operating Limits – Leaving Fluid Temperature

Leaving Fluid Temperature	Minimum	Maximum
Standard	40 °F [4.5 °C]	50 °F [10 °C]
Dual Mode / Low Temp. (with PG 30%)	22.5 °F [-5.3 °C]	50 °F [10 °C]
Dual Mode / Low Temp. (with EG 30%)	20.1°F [-6.6°C]	50 °F [10 °C]

EVAPORATOR FLUID CIRCUIT

Wide Range ΔT - Low Flow Applications

Multiple smaller chillers may be applied in series, each providing a portion of the design temperature range typical 10°F [5.5°C] each.

Chilled fluid may be recirculated through the evaporator as shown below to allow the chiller to operate with acceptable flow rates and temperature ranges (Figure 1A).

Figure 1A

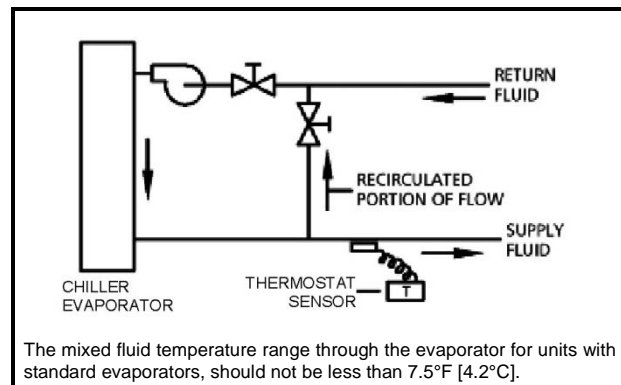

The mixed fluid temperature range through the evaporator for units with standard evaporators, should not be less than 7.5°F [4.2°C].

Narrow Range ΔT - High Flow Applications

For Narrow Range ΔT applications, a partial evaporator bypass piping and valve configuration can be used as shown below.

This permits a higher ΔT and lower ΔP (pressure drop) through the evaporator (Figure 1B).

Figure 1B

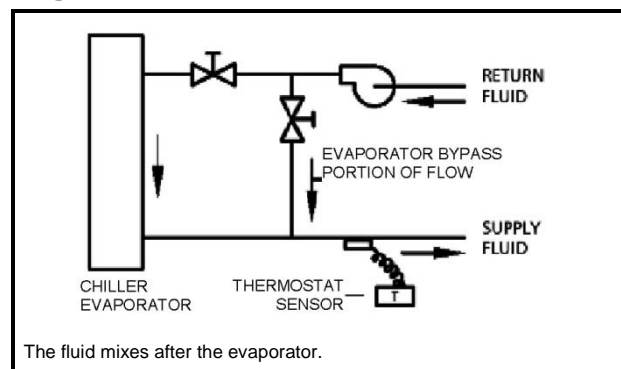

The fluid mixes after the evaporator.

Minimum Chilled Fluid Loop Volume

The evaporator fluid circuit requires a minimum system fluid volume of 3 US gallons per Ton [3.3 liters/ cooling kW] for stable operation. The minimum system fluid volume may increase up to 10 US gallons per Ton [11 liters/ cooling kW] for process cooling, low load applications with small temperature range and/or vastly fluctuating load conditions.

Tanks for System Volume Enhancement

It may be necessary to install a tank in the system to provide sufficient system fluid volume, as shown below. The tank should be baffled and piped for proper fluid mixing to prevent stratification.

Figure 2A

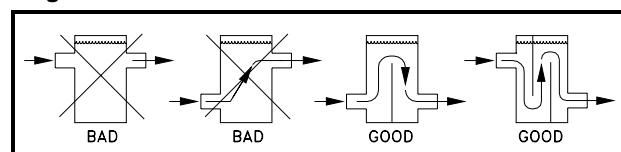

APPLICATION DATA

Figure 2B Single Loop System with Storage Tank to Increase Loop Volume

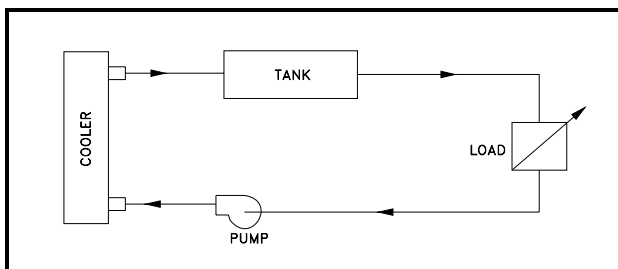
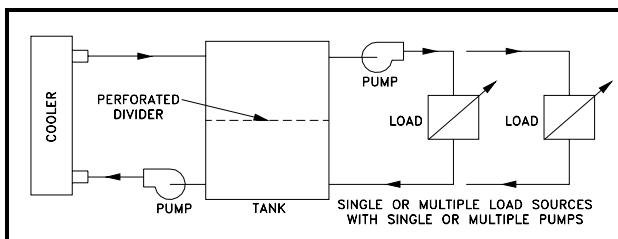

Figure 2C Primary and Secondary Loop Systems are normally used where the secondary system has variable flow and/or multiple loads. See example below.



Multiple Chillers In A Chilled Water System

Where the load is greater than available from one Helios ACHX-B, where standby capacity is required or the load profile dictates, multiple chillers may be piped in parallel. Units of equal size help to ensure fluid flow balance, but balancing valves ensure balanced flows even with dissimilar sized chillers.

Temperature controller sensors may or may not need to be moved to the common fluid piping depending on the specific application.

Parallel Chiller Applications – Both units operate simultaneously modulating with load variations. Each unit operates independently sensing its own leaving fluid temperature. The set point of each thermostat is set to maintain the desired loading scheme. (Figure 3A)

Figure 3A

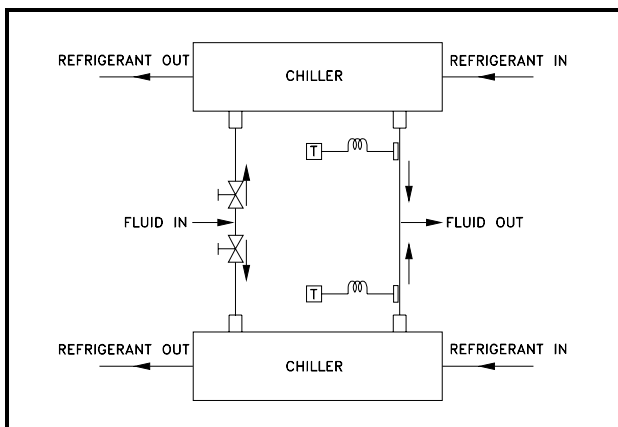

Series Chiller Applications – Where a large temperature range is required (over 25 °F [13.9 °C]), the chiller may be piped in series. In this case the units are controlled independently. The load is progressive by temperature so the chiller selections are critical. (Figure 3B)

Figure 3B

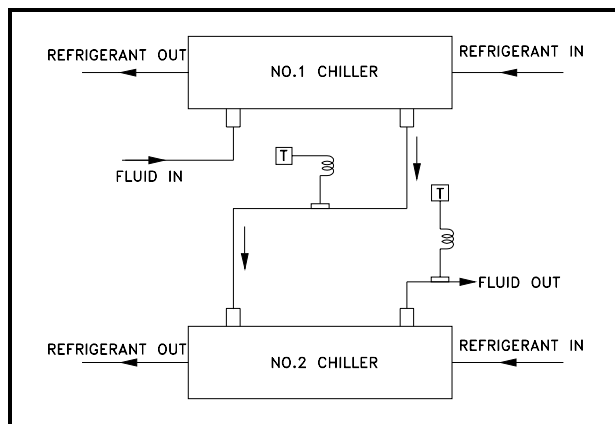

Variable Evaporator Flow

Dunham-Bush chillers are capable for variable evaporator flow system. The chiller may operate to maintain constant leaving fluid temperature with evaporator flow rate changes, with below conditions fulfilled.

- ⊗ Evaporator fluid flow rate is within minimum and maximum flow rate of the unit at all time during the operation
- ⊗ Rate of flow changed shall not exceeded 10% per minute

Failure to comply with the above conditions will cause problem to the chiller operation and may cause the chiller to shutdown.

Glycol Freeze Protection

If the chiller or fluid piping may be exposed to temperatures below freezing, glycol protection is recommended if the water is not drained. The recommended protection is 10°F [5.6°C] below the minimum ambient temperature in the equipment room and around piping. Use only glycol solutions approved for heat exchanger duty. DO NOT use automotive anti-freezing.

If the equipment is being used to supply chilled fluid 38°F [3.3°C] or below, glycol should be used to prevent freeze damage. The freeze protection level should be 15°F [8.3°C] lower than the leaving brine temperature. The use of glycol causes a performance derate as shown below which needs to be included in the unit selection procedure.

APPLICATION DATA

Table 1 : Ethylene Glycol

% E. G. By Weight	Freeze Point		C1 Capacity Factor	K1 kW Rate	G1 Flow Factor	P1 P.D. Factor
	°F	°C				
10	26.2	-3.2	0.995	0.998	1.019	1.050
15	22.4	-5.3	0.991	0.997	1.030	1.083
20	17.8	-7.9	0.988	0.996	1.044	1.121
25	12.6	-10.8	0.984	0.995	1.060	1.170
30	6.7	-14.1	0.981	0.994	1.077	1.219
35	0.0	-17.8	0.977	0.992	1.097	1.275
40	-10.0	-23.3	0.973	0.991	1.116	1.331
45	-17.5	-27.5	0.968	0.990	1.138	1.398
50	-28.9	-33.8	0.964	0.989	1.161	1.466

Table 2 : Propylene Glycol

% P. G. By Weight	Freeze Point		C2 Capacity Factor	K2 kW Rate	G2 Flow Factor	P2 P.D. Factor
	°F	°C				
10	26.1	-3.3	0.988	0.994	1.005	1.019
15	22.8	-5.1	0.984	0.992	1.008	1.031
20	19.1	-7.2	0.978	0.990	1.010	1.051
25	14.5	-9.7	0.970	0.988	1.015	1.081
30	8.9	-12.8	0.962	0.986	1.021	1.120

Table 3 : Correction Factor - Elevation

Elevation above Sea Level		Capacity Correction Factor	kW Correction Factor
Feet [m]	Meters Factor		
0	0	1.00	1.00
2000	600	0.99	1.01
4000	1200	0.98	1.02
6000	1800	0.97	1.03

Table 4 : Correction Factor - FF

Fouling Factor		Capacity Correction Factor	kW Correction Factor
Hr.ft ² .°F/BTU	m ² .°C/kW		
0.0001	0.018	1.000	1.000
0.00025	0.044	0.993	0.997
0.00050	0.088	0.978	0.990
0.00100	0.176	0.951	0.978

Note: P.D. – Pressure drop across evaporator

ICE THERMAL STORAGE SYSTEM (ITES)

The globe is progressively marching towards a serious electric energy crisis. The HVAC/R industry is shifting to operate with more efficient machines, as well as alternate system designs and solutions. Dunham-Bush, as a leader of HVAC/R solutions provider, we provide packaged solution for ITES, which include, equipments selections, chillers, Ice Cels and CPM for ITES system controls.

Dunham-Bush Chillers, with positive displacement rotary screw compressor can easily cool low temperature glycol down to 20°F [-6.7 °C] to charge the ice storage tanks. The same chiller can also produce warmer supply fluid temperature, 40 to 45 °F [4.4 to 7.2 °C], for those building systems designed for only peak shaving.

Dunham-Bush is the only HVAC/R manufacturer who can provide complete ITES packaged solution, with own products for chillers, ice storage tanks and plant room control system, with following benefits.

Demand Charge: ITES allows some of the peak demand to be shifted to low-demand nighttime periods, thus reducing demand charges for the entire year.

Energy Cost: ITES, by operating chillers at night, will fully utilize incentive on electricity night tariff, which is much lower compare to day tariff

Rebates: ITES usually qualifies for rebates offered by electric utilities or governments for equipment that shift peak loads to off-peak hours

Colder Air Temperature: ITES can produce chilled liquid at supply temperature of 38°F [3.3°C] or even lower without scarifying system's efficiencies. This realizes energy saving on chilled water pumping system, AHUs and FCUs. Colder supply air distribution lowers room humidity, and thus, comfort cooling can be achieved with higher room temperature. This reduce air conditioning load required, and therefore, reduces the installation cost and system operating cost.

Standby Cooling Capacity: Energy stored in ITES can be utilized to cater peak or unexpected loads which exceeded total cooling capacity available from the installed chillers. This is savior to the regions which having difficulties on power generation plants expansion, where with ITES, will significantly reduced total demand of the buildings.

MINIMUM CLEARANCE REQUIREMENTS

Single Pit (See Note 2)

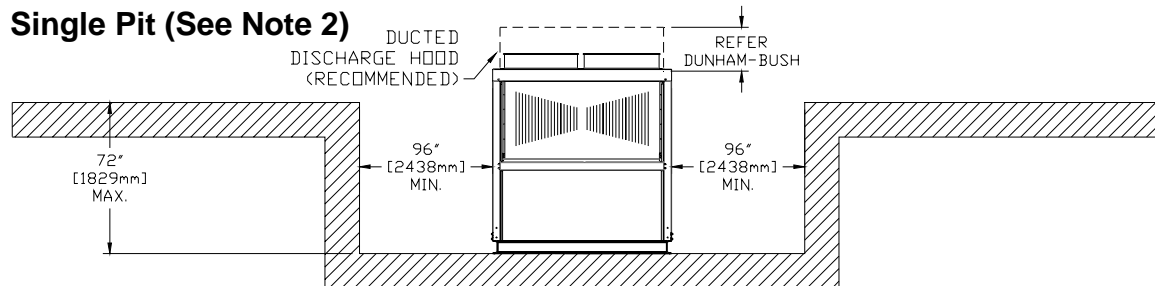

Double Pit (See Note 2)

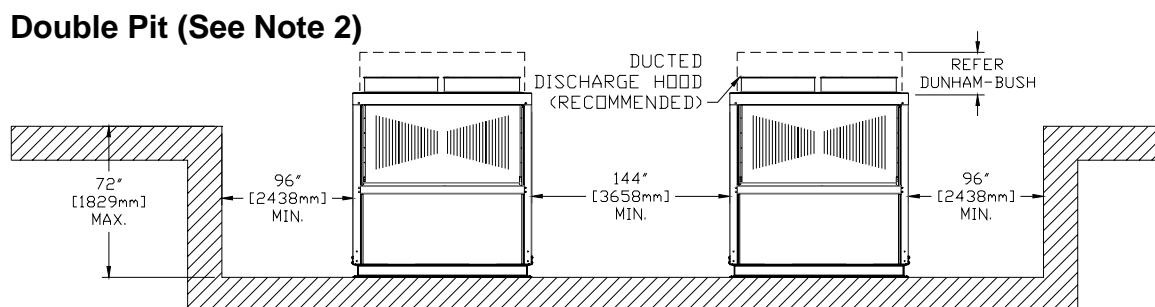

Multi Pit

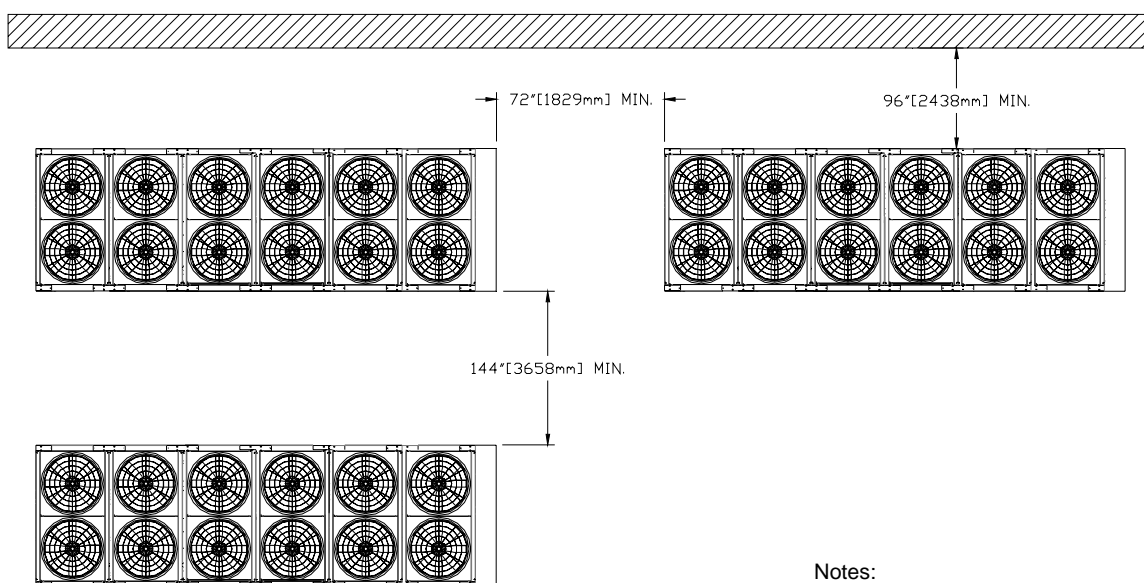

Corner Wall

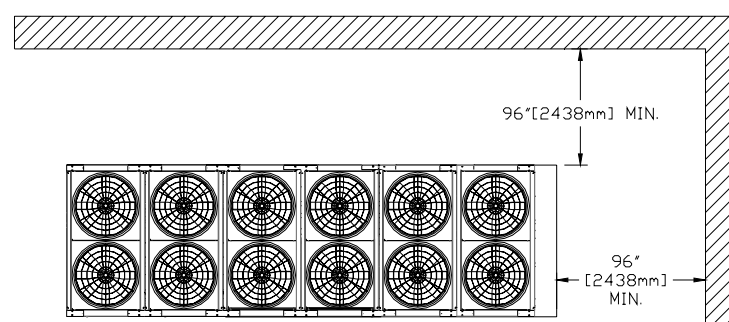

Notes:

- 1.) All dimensions are minimal, unless otherwise noted.
- 2.) Pit installations are not recommended. Re-circulation of hot condenser air in combination with surface air turbulence cannot be predicted. Hot air re-circulation will severely affect unit efficiency (EER) and can cause high pressure or fan motor temperature trips. Dunham-Bush will not be responsible for ducting fans to a higher level to alleviate the above mentioned conditions.

GUIDE SPECIFICATIONS

1.0 GENERAL

1.1 SUMMARY

Supply and commissioning of complete factory assembled air cooled screw chiller suitable for outdoor installation. The air cooled chiller shall contain rotary screw compressor(s), evaporator, air cooled condenser with coil and fan, interconnecting refrigerant piping, electronic expansion valve, control panel, chilled liquid connections. The control panel shall be fully wired by the manufacturer to connect and interlock controller, starter, protection devices with electrical power and control connections. Packaged chiller shall be factory assembled, charged and run tested with a full operating refrigerant and oil charge. The refrigerant type shall be R134a and shall not have phasing out schedule.

Contractor shall furnish and install chiller as shown and scheduled on the drawings. Unit shall be installed in accordance with this specification.

1.2 QUALITY ASSURANCE

- ✿ Chiller performance shall be rated in accordance to AHRI 550/590 standard latest edition.
- ✿ ASME standard B31.5 for Refrigerant piping
- ✿ Vessels shall be fabricated and pressure tested in accordance with ASME Boiler and Pressure vessel code, Section VIII, Division 1 "Unfired Pressure Vessels"
- ✿ Manufacturer shall have experience of minimum 15 years in manufacturing Air Cooled Screw Chillers in their facility
- ✿ Unit shall be manufactured in ISO9001 registered manufacturing facility.
- ✿ [OPTIONAL] ASHRAE Standard 15 safety code for mechanical refrigeration
- ✿ [OPTIONAL] PED certification required in Europe market place
- ✿ Factory run test: Chiller shall be pressure tested, evacuated and fully charged with refrigerant and oil. The chiller shall be run tested with water flowing through the vessels.
- ✿ Manufacturer shall have a service organization with trained service personal.

1.3 DESIGN BASE

The construction drawings indicate a system based on a selected manufacturer of equipment and the design data available to the Engineer during construction document preparation. Electrical services, size, configuration and space allocations are consistent with that manufacturer's recommendations and requirements.

Other listed or approved manufacturers are encouraged to provide equipment on this project; however, it will be the Contractor and/or Supplier's responsibility to assure the equipment is consistent with the design base. No compensation will be approved for revisions required by the design base or other manufacturers for any different services, space, clearances, etc.

1.4 DELIVERY, STORAGE AND HANDLING

Unit shall be delivered to job site fully assembled with all interconnecting refrigerant piping and internal wiring ready for field installation and charged with refrigerant and oil by manufacturer. When delivered, machine shall be stored indoors, away from construction dirt, dust, moisture or any other hazardous material that would harm the chillers. Inspect under shipping tarps, bags, or crates to be sure there is no water collected during transit. Protective shipping covers shall be kept with the unit until machine is ready for installation.

1.5 WARRANTY

Chiller manufacturer's warranty shall cover for 12 months from the date of start-up or 18 months from the date of shipment whichever is first. The start-up shall be carried out by a authorized service personnel and the warranty is limited to part replacement excluding labor and consumables such as refrigerant, oil & filter driers etc.

1.6 MAINTENANCE

Maintenance of the chillers will be the responsibility of the owner and performed in accordance with the manufacturer's instructions

2.0 PRODUCTS

2.1 OPERATING REQUIREMENTS

The units will be furnished as shown on capacity schedules and drawings. Unit performance will be in accordance with AHRI Standard 550/590.

The unit shall be capable of starting up with entering fluid temperature to the cooler at 95°F [35°C].

The unit shall be capable to produce chilled fluid temperature between 40°F to 50°F [4.5°C to 10°C] at standard operating mode.

[OPTIONAL]:

A. Dual Mode operation – The unit shall capable for ice thermal storage applications with supply brine temperature down to 18°F [-7.8°C].

B. Low Temp. Operation – The unit shall capable for process cooling application with supply fluid temperature down to 18°F [-7.8°C].

The unit shall be design to operate at ambient temperature 45°F to 115°F [7°C to 46°C].

[OPTIONAL]:

Low Ambient Operation (LA1) – The unit shall capable to operate with ambient temperature down to 14°F [-10°C].

A. Extra Low Ambient Operation (LA2) – The unit shall capable to operate with ambient temperature down to -20°F [-29°C].

Unit shall be able to operate with 3-phase 50Hz power supply with voltage +/- 10% for 400V and +6% -10% for 415V. Control Voltage shall be 115V/1ph/50Hz.

GUIDE SPECIFICATIONS

2.2 CONSTRUCTION

The unit panels, control boxes shall be constructed by heavy gauge, galvanized steel with powder coating baked finishing to pass 1000-hours salt spray test in accordance with ASTM B117 standard.

2.3 COMPRESSOR

The packaged chiller shall be furnished with Semi-hermetic rotary twin-screw compressor(s) as required, driven by a 2950 RPM 2 pole motor. Each compressor shall include oil sump. The oil differential pressure shall be controlled during operation to maintain proper oil lubrication throughout the lubrication system. An electric oil heater shall be provided in each compressor to maintain required oil temperature during shutdown period. The heater shall be energized when the chiller is switched off. Each compressor shall have a sight glass, suction filter, a discharge check valve and a discharge service valve. Compressor capacity control shall be obtained by an electrically initiated, hydraulically actuated slide valve within each compressor. The bearing shall be heavy duty, anti-friction, type, shall be able to carry both radial and thrust loads.

The compressor motor shall be semi-hermetic refrigerant gas cooled, 2 pole, squirrel cage induction type with class F insulation. Motor winding shall have thermistors embedded in the motor windings to protect motor from overheating. The thermistors shall be wired to the solid state motor protection module.

[OPTIONAL]:

Compressor service valve - Compressor discharge service valve and suction service valve are supplied to isolate the compressor from the system.

2.4 EVAPORATOR

Evaporator vessel shall be cleanable shell and tube, flooded type. Shell shall be fabricated from rolled carbon steel sheet with fusion welded seams or carbon steel standard pipes. End plates shall be of carbon steel with precision drilling, reamed in order to accommodate tubes. Intermediate tube support shall be in place to provide required tube support between tube sheets. Tubes shall be of copper, seamless, high efficient, internally enhanced and externally finned, mechanically expanded into fixed steel tube sheets. Tube diameter shall be $\frac{3}{4}$ inch and thickness shall be 0.025 inch. The flooded evaporator shall have a built in distributor for feeding refrigerant evenly under the tube bundle to produce a uniform boiling action and baffle plates shall be provided to ensure vapor separation.

Water box shall be removable type for tube cleaning. Water connections shall be with Victaulic grooves in compliance to ANSI / AWWAC-606. Vent and drain plugs are to be provided in water box. The shell side of the evaporator shall have pressure relief valve with provision for refrigerant venting.

Evaporator refrigerant side shall be designed and constructed in accordance with the ASME Code for

Unfired Pressure Vessels. Evaporator shell side shall be designed for working pressure up to 200PSIG [13.8BAR] and undergo pneumatic pressure test at 220PSIG [15.2BAR]. Tube side shall be designed for 150PSIG [10.3BAR] working pressure and undergo hydrostatic pressure test at 195PSIG [13.4BAR].

The flooded evaporator shall have an efficient and reliable oil recovery system. The oil recovery system shall insure the evaporator is operating at peak efficiency at all times and provide optimal energy efficiency during extended periods of part load. Units without such oil recovery systems shall not be acceptable.

All low temperature surfaces shall be factory insulated with 1 inch [25mm] thick Polyethylene resin having K factor of 0.26 btu-in / hr.ft².°F.

[OPTIONAL]:

- A. Evaporator Flanged Water Connection – Flanged water connection shall be provided in lieu of Victaulic connection.
- B. Double Thick Insulation – Evaporator shall be provided with 2 inch [50mm] thick closed cell insulation for extra resistance to condensation.
- C. 250PSIG [1.7MPa] Working Pressure Vessel – Evaporator with 250PSIG working pressure on shell side shall be provided.
- D. PED Compliance – Evaporator with PED approval shall be provided for installation in European countries.

2.5 CONDENSER AND FANS

Condenser Coil shall be constructed with Microchannel type aluminium alloy tube brazed together with aluminium alloy fin. The whole coil shall be made of a single type material to prevent galvanic corrosion from different metals. Microchannel coil shall come anti-corrosion coating and is able to withstand more than 1400hours Sea Water Acetic Acid Test (SWAAT) in accordance with ASTM G85-A3 standard.

The coil construction shall be of V configuration in order to increase heat transfer area and condenser divider baffles shall fully separate each condenser fan section to control the air flow by fan cycling and fan staging to maintain optimum head pressure. Coil plate shall be made of galvanized steel and divider baffles shall be made of galvanized steel with powder coating.

The fan shall be direct drive propeller type, made of heavy duty alloy blades, in order to have higher resistance for dust and sand abrasion. Fan shall be protected with powder coated steel wire fan guard.

The motor shall be 3-phase, TEFC, squirrel cage induction type with IP55 enclosure and class F insulation. The motor bearing shall be permanently lubricated. Motor shall have internal thermal protection

The fan and the motor assembly shall be rigidly secured to the casing with a heavy gauge steel powder coated fan brackets with air discharge upward.

GUIDE SPECIFICATIONS

Full pump down capacity in condenser (Al-Cu option only).

[OPTIONAL]:

- A. Microchannel Condenser Coil [E-Coating] - Condenser Coil shall be constructed with Microchannel type aluminium alloy tube brazed together with aluminium alloy fin. The whole coil shall be made of a single type material to prevent galvanic corrosion from different metals. Microchannel coil shall be electro-coated with protective coating to withstand at least 3000hours Sea Water Acetic Acid Test (SWAAT) in accordance with ASTM G85-A3 standard.
- B. Aluminum Fin/ Copper Tube – The coil shall be constructed of seamless inner-grooved copper tube and die formed aluminum fins having self spacing collars in staggered configuration. Copper tubes shall be mechanically expanded into the fins.
- C. Pre-Coated Aluminum Fin/Copper Tube Coil – Copper/Pre-coated Aluminum fin construction shall be made of seamless inner grooved copper tubes mechanically expanded into pre-coated (hydrophilic coated) aluminum fins. The tube sheet shall be of galvanized steel and the divider baffles shall be of galvanized steel with powder coating.
- D. Copper Tube/ Copper Fin Coil – Copper/Copper coil construction shall be made of seamless inner grooved copper tubes mechanically expanded into copper fins. The tube sheet shall be of galvanized steel or stainless steel and the divider baffles shall be of galvanized steel with powder coating.
- E. Post-Coated Aluminum Fin Coil – Copper tube/per-coated Aluminum fin coil construction shall be made of seamless inner grooved copper tubes mechanically expanded into Aluminum fins. The tube sheet shall be of galvanized steel. The entire fin shall be coated with anti corrosive coating after the coil fabrication. The divider baffles shall be made of galvanized steel with powder coating.
- F. Protective Grille for Condenser Coil – Protective grille shall be provided to condenser coil section to prevent unauthorized access.

2.6 REFRIGERANT CIRCUIT

The refrigerant circuit shall include discharge service valves, liquid line shut off valve, oil filter, replaceable filter drier, and sight glass at liquid line. Liquid line angle valve shall be provided for refrigerant charging. Pressure relief valves shall be provided at evaporator.

The packaged chiller shall be furnished with electronic expansion valve for precise modulation of refrigerant flow control and improve efficiency by optimizing the suction and discharge superheat. In addition, the refrigerant control system shall optimized refrigerant liquid level in the flooded evaporator to protect the

compressor from slugging liquid refrigerant. Fixed orifice control systems shall not be acceptable.

[OPTIONAL]:

- A. Heat Recovery – Factory supplied shell-and-tube heat exchanger to reclaim waste heat from the system to produce hot water up to 131°F [55°C].
- B. Hotgas Bypass – Shall be factory for operation down to approximately 10% of full load.

2.7 OIL MANAGEMENT

The chiller package shall ensure proper lubrication during the operation in order to have prolonged compressor life as well as maintaining system efficiency. An efficient pressure differential lubrication system shall be provided with oil filter, sight glass, oil sump and oil sump heater. The oil heater shall be energized during the chiller switched off to prevent oil from dilution. Oil pump shall not be acceptable.

2.8 ELECTRICAL AND CONTROL PANEL

The electrical switch gears, controller, sensor transmitters and relays shall be housed in IP54 panel. The panel casing shall be of galvanized steel with powder coating baked finishing for corrosion resistance. The panel shall be divided into two separate compartments or shall have two separate panels to house power and control devices separately.

The chiller manufacturer shall provide suitable reduced inrush starter for the compressor motor in order to minimize the starting current. The starter shall be factory mounted, wired to the motor and controller. The starter shall be able to provide adequate starting torque and the required acceleration for the compressor during starting.

The electrical panel compartment shall include:

- A. Main incoming power terminal block suitable to receive single entry of three phase 3-wire power supply with specified voltage.
- B. Circuit breaker for each compressor.
- C. Solid state / thermal compressor motor with over current protection module for each phase.
- D. Solid state compressor motor overheat protection module.
- E. Under/over voltage phase reversal and imbalance relay.

The compressor starter contactors and circuit breakers shall be wired securely to the main incoming terminal block. Solid state/ thermal external compressor over load protector, over heating protection modules, over/under voltage phase relay shall be interlocked with the compressor starter contactors to provide adequate protection to the compressor motor.

[OPTIONAL]:

- A. IP55 control panel – Option shall be offered to upgrade the standard IP54 control panel to IP55 rated.

GUIDE SPECIFICATIONS

- B. Unit Mounted Main Disconnect Switch – Non-fused disconnect switch with external lockable handle shall be provided to isolate unit main incoming power supply for servicing.
- C. Ground Fault Interrupt (GFI) – GFI shall be provided for ground fault protection of the unit.
- D. Softstarter for compressors motor – Solid state starter comes with bypass contactor shall be offered in lieu of standard starter for better compressor starting characteristic.
- E. Ammeter/ Voltmeter – Analog ammeter and voltmeter with 3-phase selector switch shall be provided for quick system voltage and current indication.

2.9 CONTROLS

2.9.1 GENERAL

The packaged chiller shall be equipped with stand along proactive advance controller which adapts to abnormal operation conditions. The unit algorithm program and operating parameters shall be stored in flash-memory that does not require a battery back-up. Controller requires back-up battery is not acceptable.

115V power supply to the control circuit shall be provided by a factory mounted control transformer installed in the panel. External power source to the control circuit is not acceptable.

The controller shall be equipped with a user friendly back-lit 132 x 64 pixels semi-graphic display and dedicated keys that provide easy access to the unit operating parameters, control set points and alarm history. There shall be dedicated physical buttons to enable user to access information, based on security level of password. There shall be min three level of password for operator, service personnel and for the critical manufacturer settings in order to protect the chiller controller from unauthorized access.

The controller shall be provided with a set of terminals that connected to various devices such as temperature sensors, pressure transducers, current transducers, solenoid valves, compressor contactors, electronic expansion valve, control relays. The controller should be able to be configured and connected multiple units that allow sequencing control without additional hardware. The controller shall be able to carry out all program operations. It shall be able to display unit operating parameters, compressor information, alarm history and shall able to modify the parameters.

The controller shall be able to carry out self-diagnostic test on the controller and the connected devices and alarm messages shall be displayed automatically on faulty devices.

All messages shall be displayed in English language. Readings and settings displayed shall be selectable between Imperial or SI units.

Leaving chilled water temperature control shall be accomplished by entering the water temperature set

point with accuracy to 0.8°F and placing the controller automatic control mode. The controller shall monitor all control functions and move the compressor slide valve to the calibrated position. The compressor loading cycle shall be programmable and shall be adjusted to the building load requirement. The loading adjustable range shall be from 0.1% to 0.4% per increment to prevent excessive demand hike at start up.

The controller shall continuously monitor evaporator leaving water temperature, rate of change of chilled water leaving temperature, evaporator and condenser pressure; compressor amp draw; and discharge refrigerant temperature.

The controller shall be capable to accept low level remote control signal. Remote Start/Stop shall be provided as standard for unit start/stop by external on/off signal.

[OPTIONAL]:

Chilled Water Temperature Reset – The controller shall be capable to accept a 0 to 5VDC chilled water temperature reset signal to reset the chilled water supply temperature setpoint, based on external demand.

Demand Limit / Current Limit – The controller shall be capable to accept a 0 to 5VDC demand limit signal to limit the compressors operating current during the unit operation.

The electrical control panel shall be wired to permit fully automatic operation during - initial start-up, normal operation, and shutdown conditions. The control system shall contain the following control, displays and safety devices:

2.9.2 AUTOMATIC CONTROLS

- ⊗ Compressor motor increment contactors
- ⊗ Start delay timer
- ⊗ Anti-recycle timer
- ⊗ Oil sump heater interlock relays
- ⊗ Chilled water pump on/off control
- ⊗ Programmable with Seven day operation cycle

2.9.3 MANUAL CONTROLS

- ⊗ Auto/Local/Remote switch
- ⊗ Control circuit stop and start switches
- ⊗ Compressor enable switch

[OPTIONAL]:

Dual mode changeover switch – Digital input to changeover unit operation from chiller mode to freezing mode.

2.9.4 INDICATOR LIGHTS

- ⊗ Compressor Motor high temperature
- ⊗ Compressor motor overload
- ⊗ System common alarm

The control system shall be provided with an anti-recycle device. The control shall limit compressor starting to a minimum of 15 minutes between starts.

GUIDE SPECIFICATIONS

2.9.5 REFRIGERANT CONTROLS

- ✿ Refrigerant flow control shall be carried out electronically by a precision electronic expansion valve
- ✿ Compressor loading and unloading solenoid valves

2.9.6 SYSTEM INFORMATION

The chiller display shall provide following operating information.

- ✿ Leaving chilled water temperature
- ✿ Entering Chilled water temperature
- ✿ Compressor discharge temperature
- ✿ Leaving chilled water temperature derivative
- ✿ Evaporator pressure
- ✿ Condenser pressure
- ✿ Ambient Temperature
- ✿ Compressor amps draw for each compressor
- ✿ Compressor elapsed run time of each compressor
- ✿ Compressor start status
- ✿ Oil level sensor status
- ✿ Water flow switch status
- ✿ External start/stop command status
- ✿ Percentage of compressor capacity
- ✿ Electronic expansion valve percentage of opening

[OPTIONAL]:

- ✿ Operating supply Voltage
- ✿ Chilled water temperature reset value
- ✿ Demand limiting value

2.9.7 SAFETY PROTECTION

- ✿ Short circuit protection.
- ✿ Compressor motor over load protection (3 phase)
- ✿ Under or over voltage and phase failure relay
- ✿ Reverse rotation
- ✿ Compressor motor overheat protection
- ✿ High discharge temperature protection
- ✿ Low oil level protection via optical sensor
- ✿ High condenser pressure
- ✿ Low evaporator pressure
- ✿ Low differential pressure
- ✿ Freeze protection (low chilled liquid leaving temperature)
- ✿ Chilled water flow loss
- ✿ Compressor run error
- ✿ Power loss
- ✿ Sensor error
- ✿ Refrigerant loss
- ✿ Low Ambient Lockoff

Controller shall be able to retain up to 99 alarm histories complete with time of failure and all critical sensor readings. This aids service technicians in their trouble shooting task enabling downtime and nuisance trip-outs to be minimized.

2.9.8 REMOTE MONITORING (BMS INTERFACING)

The controller shall be designed to make easy on BMS interfacing by just an optional add-on communication card.

Various communication protocols as below shall be offered for user's selection.

- ✿ Modbus RTU RS485 / TCPIP
- ✿ BACnet TCPIP / MsTP / PTP
- ✿ LONworks

2.9.9 OPTIONAL ACCESSORIES

Factory shall supply below accessories for customer's field installation.

- ✿ Evaporator Water Flow Switch – Weather tight flow switch with three options for customer's selection; Flow switch with CE mark; NEMA 1 and NEMA 4 rated flow switch
- ✿ Rubber-In-Shear Isolators
- ✿ Spring Isolators

3.0 EXECUTION

3.1 INSTALLATION

Chiller shall be installed strictly according to manufacturer's recommendations as stipulated in the installation manual, drawings and tender documents. Care should be taken to provide necessary service clearance as required in the manufacturer's drawing. Install the strainers at the inlet to the evaporator to prevent debris or other particles entering to the evaporator during piping work and initial flushing the system. Required coordination to be done with the electrical contractor and the control contractors to ensure electrical supply and required communications links are established.

3.2 START-UP/COMMISSIONING

Chiller shall be commissioned by a service representative from manufacturer or by their local representative. The service personnel shall be trained and authorized by the manufacturer for start up of the supplied units. The start-up shall include briefing operators on chiller operations and maintenance as well.



Malaysia

Lot 5755-6,
Kidamai Industrial Park,
Bukit Angkat,
43000 Kajang,
Selangor, Malaysia

Tel: +603-8924 9000
Fax: +603-8739 5020

China

No. 1 Dunham-Bush Road,
Laishan District,
Yantai,
Shandong Province,
China 264003

Tel: +86-535-739 7888
Fax: +86-535-739 7999

United States of America

1800 SE 38th Avenue,
Homestead,
Florida 33035
United States of America

Tel: +1(786)-800 9999
Fax: +1(786)-527 3539

India

Unit No : 804-805 , 8th Floor,
Spaze Platinum Tower,
Sohna Road, Sector-47, Gurgaon
Haryana-122018, India

Tel: +91-124-414 4430

United Arab Emirates

Office # 2606,
Fortune Executive Towers,
Cluster T1, Jumeirah Lake Tower
Dubai, UAE

Tel: +971-4-443 9207
Fax: +971-4-443 9208

South Africa

No. 57 Sovereign Drive
Route 21 Corporate Park
Irene, Pretoria
South Africa

Tel: +27-12-345 4202
Fax: +27-12-345 4203

Singapore

2 Kallang Pudding Road
#07-07 Mactech Building
Singapore 349307

Tel: +65-6842 2012
Fax: +65-6842 2013

Indonesia

The Boulevard Office,
3F2 Jl. Fachrudin No.5,
Kp. Bali, Tanah Abang
Jakarta Pusat - 10250, Indonesia

Tel: +62-21-2123 1392

Thailand

48/39 Soi Praditmanutham 19
Praditmanutham Road,
Lat Pharo, Bangkok 10230
Thailand

Tel: +662-002 2125

Vietnam

10th Floor, Nam A Bank Tower,
201-203 Cach Mang Thang 8 Street,
Ward 4, District 3, Ho Chi Minh City,
Vietnam

Tel: +84-8-6290 3108
Fax: +84-8-6290 3109

DUNHAM-BUSH®

info@dunham-bush.com
www.dunham-bush.com



Products that perform...By people who care

Manufacturer reserves the right to change specifications without prior notice.

M-S-04108B-0225